

TTC 標準

TTC STANDARD

JP-3GA-25.323(R99)

パケットデータコンバージェンス  
プロトコル ( P D C P ) 仕様

Description of the Packet Data Convergence  
Protocol(PDCP) protocol

第3版

2001年5月14日制定

社団法人  
情報通信技術委員会

THE TELECOMMUNICATION TECHNOLOGY COMMITTEE



本書は、(社)情報通信技術委員会が著作権を保有しています。

内容の一部又は全部を(社)情報通信技術委員会の許諾を得ることなく複製、転載、改変、転用及びネットワーク上での送信、配布を行うことを禁止します。

パケットデータコンバージェンスプロトコル (PDCP) 仕様

[Packet Data Convergence Protocol (PDCP) Specification]

< 参考 > [Remarks]

1 . 英文記述の適用レベル [Application level of English description]

適用レベル [Application level] : E3

本標準の本文、付属資料および付録の文章および図に英文記述を含んでいる。

[English description is included in the text and figures of main body, annexes and appendices.]

2 . 国際勧告等の関連 [Relationship with international recommendations and standards]

本標準は、2000 年 12 月に 3GPP で承認された Technical Specification 25.323 (Version 3.3.0) に準拠している。

[This standard is standardized based on the Technical Specification 25.323 (Version 3.3.0) approved by 3GPP in Dec. 2000.]

3 . 上記国際勧告等に対する追加項目等 [Departures from international recommendations]

3.1 オプション選択項目 [Selection of optional items]

なし [None]

3.2 ナショナルマター項目 [Items of national matter]

なし [None]

3.3 原標準に対する変更項目 [Changes to original standard]

(1) 原標準が参照する標準のうち、TTC 標準・ARIB 標準に置き換える項目。 [Standards referred to in the original standard, which are replaced by TTC/ARIB standards.]

表 1 に示す。 [Refer to Table 1.]

(2) 本標準で追加した項目。 [Items added to the original standard]

なし [None]

(3) 本標準で削除した項目。ただし、本標準の理解を助けるために記述は残している。 [Items deleted from the original standard]

なし [None]

(4) 本標準で修正した項目。 [Items changed from the original standard]

なし [None]

3.4 原標準との章立て構成比較 [Difference in chapter ordering from the original standard.]

原標準との章立て構成の相違はない。

[There is no difference in chapter ordering from the original standard.]

#### 4 . 改版の履歴 [Change history]

版数 [Revision]	制定日 [Date]	改版内容 [Contents]
第 1 版 [V.1]	2000 年 3 月 31 日	制定 [Newly standardized]
第 2 版 [V.2]	2000 年 11 月 30 日	3GPP TS25.323 が V.3.2.0 に改版・承認されたことに伴う改版 [Revised based on the Technical Specification 25.323 (Version 3.2.0) approved by 3GPP ]
第 3 版 [V.3]	2001 年 5 月 14 日	3GPP TS25.323 が V.3.3.0 に改版・承認されたことに伴う改版 [Revised based on the Technical Specification 25.323 (Version 3.3.0) approved by 3GPP ]

#### 5 . 工業所有権 [IPR]

本標準に関わる「工業所有権等の実施の権利に係る確認書」の提出状況は、TTC ホームページでご覧になれます。

#### 6 . その他 [Others]

なし [None]

表 1 本標準で置き換えて参照する標準 [Table 1 Replaced standards referred]

原標準 [original standard]	置き換える標準 [replacement]
3G TS 25.401 Title : UTRAN Overall Description	ARIB 標準 ARIB STD-T63-25.401 Title: IMT-2000 DS-CDMA System UTRAN Overall Description
3G TR 25.990 Title : Vocabulary for the UTRAN	ARIB 標準 ARIB TR-T-12-25.990 Title : IMT-2000 DS-CDMA System Vocabulary for the UTRAN
3G TS 25.301 Title : Radio Interface Protocol Architecture	ARIB 標準 ARIB STD-T63-25.301 Title : IMT-2000 DS-CDMA System Radio Interface Protocol Architecture
3G TS 25.303 Title : Interlayer Procedures in Connected Mode	ARIB 標準 ARIB STD-T63-25.303 Title : IMT-2000 DS-CDMA System Interlayer Procedures in Connected Mode
3G TS 25.322 Title : RLC Protocol Specification	TTC 標準 JP-3GA-25.322 (R99) Title : RLC プロトコル仕様
3G TS 25.331 Title : RRC Protocol Specification	TTC 標準 JP-3GA-25.331 (R99) Title : RRC プロトコル仕様
3G TS 23.121 Title : Architectural Requirements for Release 1999	TTC 標準 JP-3GA-23.121 (R99) Title : R99 アーキテクチャ要求条件
3G TS 23.060 Title : General Packet Radio Service (GPRS); Service description; Stage 2	TTC 標準 JP-3GA-23.060 (R99) Title : 汎用パケット無線 (GPRS) サービス記述 ステージ 2

# 3GPP TS 25.323 V3.3.0 (2000-09)

---

*Technical Specification*

## **3rd Generation Partnership Project; Technical Specification Group Radio Access Network; Packet Data Convergence Protocol (PDCP) Specification (Release 1999)**



The present document has been developed within the 3<sup>rd</sup> Generation Partnership Project (3GPP™) and may be further elaborated for the purposes of 3GPP.

The present document has not been subject to any approval process by the 3GPP Organizational Partners and shall not be implemented. This Specification is provided for future development work within 3GPP only. The Organizational Partners accept no liability for any use of this Specification. Specifications and reports for implementation of the 3GPP™ system should be obtained via the 3GPP Organizational Partners' Publications Offices.

---

Keywords

---

UMTS, radio

**3GPP**

Postal address

---

3GPP support office address

---

650 Route des Lucioles - Sophia Antipolis  
Valbonne - FRANCE  
Tel.: +33 4 92 94 42 00 Fax: +33 4 93 65 47 16

Internet

---

<http://www.3gpp.org>

---

**Copyright Notification**

---

No part may be reproduced except as authorized by written permission.  
The copyright and the foregoing restriction extend to reproduction in all media.

© 2000, 3GPP Organizational Partners (ARIB, CWTS, ETSI, T1, TTA, TTC).  
All rights reserved.

---

# Contents

Foreword.....	4
1 Scope .....	5
2 References .....	5
3 Abbreviations.....	5
4 General .....	6
4.1 Objective .....	6
4.2 Overview on sublayer architecture.....	6
5 Functions .....	7
5.1 Header Compression .....	7
5.1.1 Assignment of PID values .....	8
5.1.2 TCP/IP and UDP/IP header compression (RFC 2507) .....	9
5.1.2.1 Assignment of PID values for RFC2507 .....	9
5.2 Multiplexing.....	9
5.3 Data Transfer.....	9
5.3.1 Data transfer over acknowledged mode RLC.....	9
5.3.2 Data transfer over unacknowledged and transparent mode RLC.....	10
5.4 SRNS Relocation .....	10
5.4.1 PDCP Sequence Numbering.....	11
6 Services.....	11
6.1 Services provided to upper layers .....	11
6.2 Services expected from RLC layer.....	11
7 Elements for layer-to-layer communication .....	12
7.1 Primitives between PDCP and upper layers.....	12
8 Elements for peer-to-peer communication .....	13
8.1 Protocol data units.....	13
8.2 Formats.....	13
8.2.1 PDCP-No-Header PDU .....	13
8.2.2 PDCP Data PDU.....	13
8.2.3 PDCP SeqNum PDU .....	14
8.3 Parameters.....	14
8.3.1 PDU Type.....	14
8.3.2 PID.....	14
8.3.3 Data .....	14
8.3.4 Sequence number.....	15
9 Handling of unknown, unforeseen and erroneous protocol data .....	15
<b>Annex A (informative): Change history .....</b>	<b>16</b>



---

## Foreword

This Technical Specification (TS) has been produced by the 3<sup>rd</sup> Generation Partnership Project (3GPP).

The contents of the present document are subject to continuing work within the TSG and may change following formal TSG approval. Should the TSG modify the contents of the present document, it will be re-released by the TSG with an identifying change of release date and an increase in version number as follows:

Version x.y.z

where:

- x the first digit:
  - 1 presented to TSG for information;
  - 2 presented to TSG for approval;
  - 3 or greater indicates TSG approved document under change control.
- y the second digit is incremented for all changes of substance, i.e. technical enhancements, corrections, updates, etc.
- z the third digit is incremented when editorial only changes have been incorporated in the document.

---

# 1 Scope

The present document provides the description of the Packet Data Convergence Protocol (PDCP).

PDCP provides its services to the NAS at the UE or the relay at the Radio Network Controller (RNC).

PDCP uses the services provided by the Radio Link Control (RLC) sublayer.

The main functions of PDCP are:

- compression of redundant Network PDU control information (header compression);
- transfer of packet data protocol user data using services provided by RLC protocol.

The following functions are not part of release 1999 but will be included in Release 2000:

- multiplexing of different RBs onto the same RLC-entity;
- transfer of states and header compression context information to target SRNC during SRNS relocation.

---

# 2 References

The following documents contain provisions which, through reference in this text, constitute provisions of the present document.

- References are either specific (identified by date of publication, edition number, version number, etc.) or non-specific.
- For a specific reference, subsequent revisions do not apply.
- For a non-specific reference, the latest version applies.

- [1] 3GPP TS 25.401: "UTRAN Overall Description".
- [2] 3GPP TR 25.990: "Vocabulary for the UTRAN".
- [3] 3GPP TS 25.301: "Radio Interface Protocol Architecture".
- [4] 3GPP TS 25.303: "Interlayer Procedures in Connected Mode".
- [5] 3GPP TS 25.322: "RLC Protocol Specification".
- [6] 3GPP TS 25.331: "RRC Protocol Specification".
- [7] 3GPP TS 23.121: "Architectural Requirements for Release 1999".
- [8] IETF RFC 2507: "IP Header Compression".
- [9] 3GPP TS 23.060: "General Packet Radio Service (GPRS); Service description; Stage 2".

---

# 3 Abbreviations

For the purposes of the present document, the following abbreviations apply:

AS	Access Stratum
C-SAP	Control Service Access Point
IETF	Internet Engineering Task Force
IP	Internet Protocol
L2	Layer 2 (data link layer)
L3	Layer 3 (network layer)

NAS	Non Access Stratum
PDCP	Packet Data Convergence Protocol
PDU	Protocol Data Unit
PID	Packet Identifier
RB	Radio Bearer
RFC	Request For Comments
RLC	Radio Link Control
RRC	Radio Resource Control
RTP	Real Time Protocol
TCP	Transmission Control Protocol
UDP	User Datagram Protocol
UE	User Equipment
UMTS	Universal Mobile Telecommunications System
UTRA	UMTS Terrestrial Radio Access
UTRAN	UMTS Terrestrial Radio Access Network

---

## 4 General

### 4.1 Objective

The present document describes the functionality of the UTRAN PDCP. The overall UTRAN logical architecture is defined in 3GPP TS 25.301 [3].

Network layer protocols are intended to be capable of operating over services derived from a wide variety of subnetworks and data links. UMTS supports several network layer protocols providing protocol transparency for the users of the service. At that point of view supported protocols are IPv4 and IPv6. Introduction of new network layer protocols to be transferred over UTRAN shall be possible without any changes to UTRAN protocols. Therefore, all functions related to transfer of packets from higher layers (PDCP SDUs) shall be carried out in a transparent way by the UTRAN network entities. This is one of the requirements for UTRAN PDCP.

Another requirement for the PDCP is to provide functions that help to improve channel efficiency. This requirement is fulfilled by the possibility to implement different kinds of optimization methods. The currently known methods are standardised IETF header compression algorithms.

Multiplexing of RBs onto the same RLC entity will be included in Release 2000 but is not available in Release 1999. Therefore, in Release 1999 every RB, is connected to one PDCP entity and one PDCP entity is connected to one RLC entity. The PDCP entities are located in the PDCP sublayer.

Every PDCP entity uses zero, one or several header compression algorithm types with certain parameters. Several PDCP entities may use the same algorithm type. The algorithm types and their parameters are negotiated by RRC and indicated to PDCP through the PDCP Control Service Access Point (PDCP-C-SAP).

Since the adaptation of different network layer protocols to PDCP is implementation dependent, it is not defined in the present document.

### 4.2 Overview on sublayer architecture

Figure 1 shows the model of the PDCP within the UTRAN protocol architecture. Every PDCP-SAP uses exactly one PDCP entity. Each PDCP entity uses none, one or several header compression algorithm types.

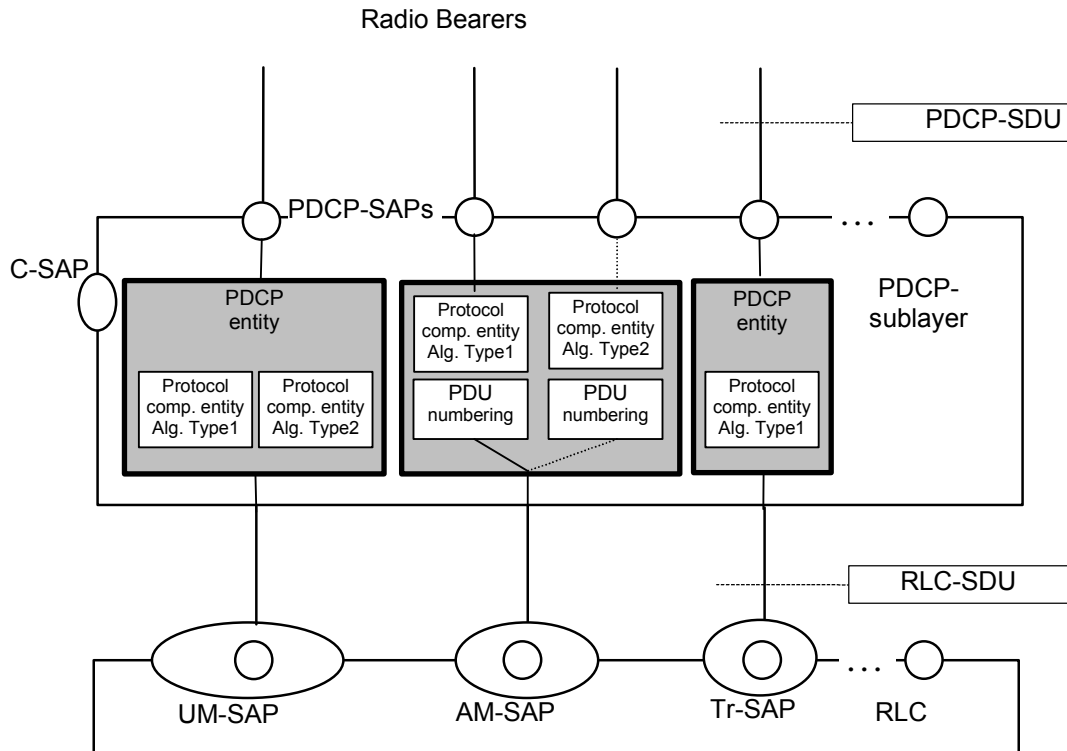

**Figure 1: PDCP structure**

Figure 1 represents only one possible structure for PDCP and this should not restrict implementation. However, subclause 5.1 shall be adhered to.

## 5 Functions

Packet Data Convergence Protocol shall perform the following functions:

- header compression and decompression of IP data streams (e.g., TCP/IP and RTP/UDP/IP headers) at the transmitting and receiving entity, respectively. The header compression method is specific to the particular network layer, transport layer or upper layer protocol combinations e.g. TCP/IP and RTP/UDP/IP
- transfer of user data. Transmission of user data means that PDCP receives PDCP SDU from the NAS and forwards it to the RLC layer and vice versa
- maintenance of PDCP sequence numbers for radio bearers that are configured to support lossless SRNS relocation
- multiplexing of different RBs onto the same RLC entity. Multiplexing is not part of Release 1999 but will be included in Release 2000

### 5.1 Header Compression

The header compression method is specific for each network layer protocol type. The network layer protocol type is indicated during PDP context activation as defined in 23.060 [9]. The header compression algorithms and their parameters are negotiated by RRC for each PDCP entity and indicated to PDCP through the PDCP-C-SAP. Compressor and decompressor initiated signalling between peer PDCP entities, during operation, is carried out in the user plane.

The PDCP layer shall be able to support several header compression algorithms and it shall always be possible to extend the list of supported algorithms in the future.

The PDCP layer can have one or several PDCP entities. Each PDCP entity may use zero, one, or several header compression algorithms. It shall be possible to establish several header compression algorithms of different types related to one PDCP entity. Different PDCP entities may include header compression algorithms of the same type.

Figure 1 shows an example how PDCP may be configured.

### 5.1.1 Assignment of PID values

PDCP shall be able to distinguish different types of header compression packets to handle them with a correct header compression algorithm and furthermore to indicate the type of the packet within a certain algorithm. This is realised by utilising the PID field in the PDU structure. The table is reconfigured every time the PDCP entity is reconfigured.

The following table illustrates an example of the PID value allocation table when three arbitrary header compression methods (RFC 2507 [8], Methods A and B) are configured for one PDCP entity.

**Table 1: Example of the PID value allocation table**

PID Value	Optimization method	Packet type
0	No header compression	-
1	RFC2507	Full header
2	RFC2507	Compressed TCP
3	RFC2507	Compressed TCP nondelta
4	RFC2507	Compressed non TCP
5	RFC2507	Context state
6	Method A	Uncompressed TCP/IP
7	Method A	Compressed TCP/IP
8	Method B	Uncompressed IP/UDP/RTP
9	Method B	Compressed IP/UDP/RTP
...	Unassigned value	-

The assignment of the PID values follow the general rules listed below:

- PID value 0 is reserved permanently for no compression;
- PID values are assigned in ascending order, starting from 1;
- PID values are assigned independently to each PDCP entity;
- PID values are reassigned for the PDCP entity after renegotiation of the header compression algorithms;
- the list of negotiated (or re-negotiated) header compression entities shall be examined, starting from the first one in the list. The number of PID values to be assigned is specified in the subclause for this algorithm;
- if there are not enough unused PID values to be assigned to a header compression algorithm, the negotiated header compression entities using this algorithm shall be ignored without error notification;
- PID values that are used and are not defined invalidate the PDCP PDU;
- for a certain algorithm in a PDCP entity the assignment of PID values starts from (n+1) where n is the number of PID values already assigned to other algorithms. The assignment is done in the order the algorithms are negotiated by RRC. In the example given in table 1 RFC 2507 was the first, Method A was the second and Method B was the third algorithm in the PDCP Info information element exchanged between peer RRC entities. The PID follows this order.

The used header compression algorithm and the packet type are unambiguously known by the basis of the PID value and shall apply to peer PDCP entities. While transferring data, the PID values are conveyed in the field of the PDCP header belonging to the PDCP PDU. Any successfully negotiated algorithm may be used for header compression of a PDCP SDU.

## 5.1.2 TCP/IP and UDP/IP header compression (RFC 2507)

Detailed operation of the RFC 2507 header compression is described in clause 3 of the IETF specification RFC 2507 [8]. Furthermore the mechanisms related to error recovery and packet reordering are described in clauses 10 and 11 of the RFC 2507. These mechanisms shall be included in the functionality of the header compression supported by PDCP.

### 5.1.2.1 Assignment of PID values for RFC2507

The following PID values shall be assigned to the RFC 2507 header compression in the order presented in the table where n is the number of PID values already assigned to other algorithms.

**Table 2: PID values assigned to RFC 2507 header compression algorithm**

PID value	Optimization method	Packet type
n+1	RFC 2507	Full header
n+2	RFC 2507	Compressed TCP
n+3	RFC 2507	Compressed TCP non-delta
n+4	RFC 2507	Compressed non-TCP
n+5	RFC 2507	Context state

## 5.2 Multiplexing

Multiplexing of different RBs onto the same RLC entity is not part of Release 1999 but will be included in Release 2000.

## 5.3 Data Transfer

### 5.3.1 Data transfer over acknowledged mode RLC

If header compression is negotiated the PDCP entity shall perform header compression upon reception of a PDCP-DATA Req. The PDCP-PDU is then delivered in RLC-AM-DATA Req to RLC.

During operation, when the peer PDCP entity receives the PDCP-PDU in a RLC-AM-DATA Ind primitive, the PDCP entity shall perform the header decompression (if negotiated) of PDCP-PDU to obtain the PDCP SDU and deliver the PDCP SDU to the PDCP user with the PDCP-DATA Ind. The following figure illustrates data transfer over acknowledged mode RLC.

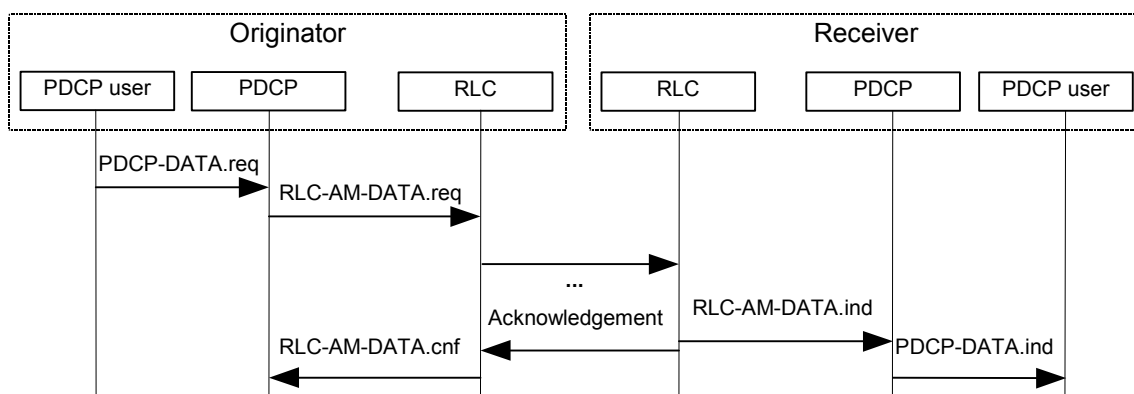
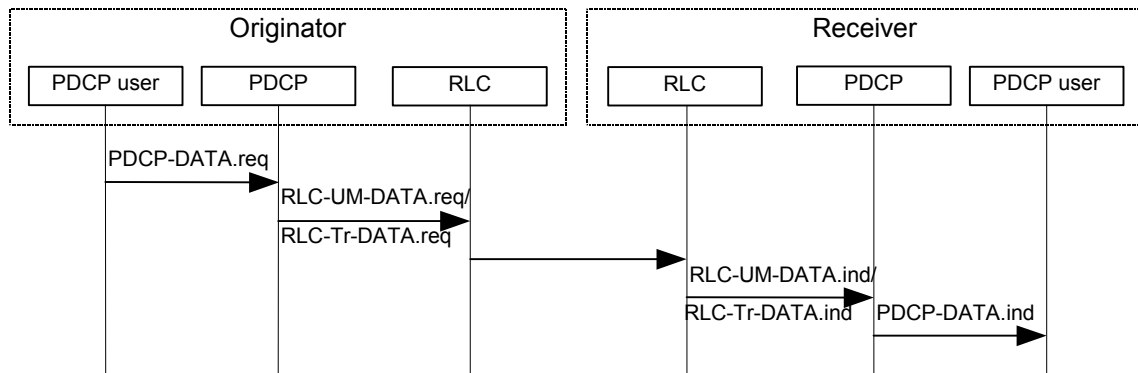

**Figure 2: PDCP data transfer over acknowledged mode RLC**

### 5.3.2 Data transfer over unacknowledged and transparent mode RLC

If header compression is negotiated the PDCP entity shall perform header compression upon reception of a PDCP-DATA.Req. The PDCP-PDU is then delivered in RLC-UM-DATA.Req or RLC-Tr-DATA.Req to RLC.

When the peer PDCP entity receives the PDCP-PDU in the RLC-UM-DATA.Ind or RLC-Tr-DATA.Ind primitive, the PDCP entity shall perform the header decompression (if negotiated) of PDCP-PDU to obtain the PDCP SDU and deliver the PDCP SDU to the PDCP user with the PDCP-DATA.Ind. The following figure illustrates data transfer over unacknowledged and transparent mode RLC.



**Figure 3: PDCP data transfer over unacknowledged or transparent mode RLC**

## 5.4 SRNS Relocation

Lossless SRNS relocation is only applicable when RLC is in in-sequence delivery and acknowledged mode PDCP will only support lossless SRNS relocation if it is 'capable' of doing so. This is indicated by RRC in the IE "Support for lossless SRNS relocation" in "PDCP Capability" and "PDCP info".

The PDCP layer shall, for those radio bearers that are configured to support lossless SRNS relocation:

- support PDCP sequence numbering as specified in subclause 5.4.1.

The PDCP layer shall carry out the following during lossless SRNS relocation:

- provide unconfirmed PDCP SDUs and sequence numbers for forwarding to the target RNC

For each radio bearer, the Receive PDCP Sequence Number of the next PDCP SDU expected to be received is transferred from the source to target SRNC. For each radio bearer the source SRNC forwards to the target SRNC the downlink PDCP-SDUs. Source SRNC provides the Send PDCP sequence number of the first PDCP SDU to be forwarded to the target SRNC.

The target SRNC shall send to the UE the next expected UL Receive PDCP Sequence Number. The UE shall send to the target SRNC the DL Receive PDCP Sequence Number of the next expected PDCP SDU. The successfully transmitted PDCP SDUs are thus confirmed. More detailed descriptions of this procedure can be found in [4] and [9].

The reset of all compression entities, for an RB, shall be made during SRNS relocation. Header compression is still possible during relocation. Negotiated compression parameters remain valid during reset, but all state information is initialised, e.g. header compression contexts. Therefore, in header compression case, the first 'compressed' packet is a full header. For Release 2000, it may be considered not to reset the PDCP entity, internal protocol information, i.e. states and header compression contexts, but to forward these from the source SRNC to target SRNC. Header compression for a PDCP entity can then continue from the state that it had directly before SRNS relocation.

## 5.4.1 PDCP Sequence Numbering

PDCP sequence numbering is only applicable when lossless SRNS relocation is to be supported. The value of the PDCP sequence number ranges from 0 to 65535. The PDCP SN window size indicates the maximum number of PDCP PDUs that can be numbered at any given time. The PDCP SN window size is negotiated by RRC. When the PDCP entity is setup for the first time for the PDCP user the PDCP sequence numbers are initialised to zero.

For each radio bearer:

- an UL\_Send PDCP sequence number is associated with each sent PDCP-PDU in the UE and is incremented by one when a PDCP PDU is delivered to RLC;
- a DL\_Send PDCP sequence number is associated with each sent PDCP-PDU in UTRAN and is incremented by one when a PDCP PDU is delivered to RLC;
- an UL\_Receive PDCP sequence number is associated with each received PDCP-PDU in UTRAN and is incremented by one when a PDCP PDU is received from RLC or is incremented by one for each discarded RLC SDU, as indicated by the RLC SDU Discard function [5];
- a DL\_Receive PDCP sequence number is associated with each received PDCP-PDU in the UE and is incremented by one when a PDCP PDU is received from RLC or is incremented by one for each discarded RLC SDU, as indicated by the RLC SDU Discard function [5].

PDCP sequence numbers are never decremented in the PDCP Tx.

PDCP SeqNum PDUs shall be sent by the peer PDCP entities when synchronization of the PDCP SN is required. It shall only be used for radio bearers that support or are configured / reconfigured to support lossless SRNS relocation. Synchronization of PDCP SN is required after RLC reset, RB reconfiguration or reception of invalid next expected UL/DL Receive PDCP Sequence Number after relocation.

.When a PDCP entity receives a PDCP SeqNum PDU, the receive PDCP sequence number shall be set to the value indicated in the PDCP SeqNum PDU.

PDCP SeqNum PDUs shall not be delivered to RLC after RLC has confirmed the successful transmission of a RLC SDU which contained a numbered PDCP PDU.

---

# 6 Services

## 6.1 Services provided to upper layers

The following services are provided by PDCP to upper layers:

- PDCP SDU delivery.

## 6.2 Services expected from RLC layer

For a detailed description of the following functions see [5].

- Data transfer in acknowledged mode.
- Data transfer in unacknowledged mode.
- Data transfer in transparent mode.
- Segmentation and reassembly.
- In-Sequence delivery.



## 7 Elements for layer-to-layer communication

The interaction between the PDCP layer and other layers are described in terms of primitives where the primitives represent the logical exchange of information and control between the PDCP layer and other layers. The primitives shall not specify or constrain implementations.

### 7.1 Primitives between PDCP and upper layers

The primitives between PDCP and upper layers are shown in table 3.

**Table 3: Primitives between PDCP and upper layers**

Generic Name	Parameter			
	Req.	Ind.	Resp.	Conf.
PDCP-DATA	Data	Data	Not Defined	Not Defined
CPDCP-CONFIG	PDCP-Info, RLC-SAP SN_Sync	Not Defined	Not Defined	Not Defined
CPDCP-RELEASE	RLC-SAP	Not Defined	Not Defined	Not Defined
CPDCP-SN	PDCP SN	Not Defined	Not Defined	Not Defined
CPDCP-RELOC	Receive_SN	Not Defined	Not Defined	Receive_SN, Send_SN

Each Primitive is defined as follows:

- a) PDCP-DATA-Req./Ind.
  - PDCP-DATA-Req is used by higher user-plane protocol layers to request a transmission of higher layer PDU.
  - PDCP-DATA-Ind is used to deliver PDCP SDU that has been received to upper user plane protocol layers.
- b) CPDCP-CONFIG-Req.
  - CPDCP-CONFIG Req is used to configure and – in case of already existing PDCP entity – to reconfigure a PDCP entity and to assign it to the radio bearer associated with that entity.
- c) PDCP-RELEASE-Req.
  - CPDCP-RELEASE-Req is used by RRC to release a PDCP entity.
- d) PDCP-SN-Req.
  - CPDCP-SN-Req is used to transfer the PDCP SN to PDCP.
- e) CPDCP-RELOC-Req.
  - CPDCP-RELOC-Req initiates the SRNS relocation procedure in PDCP for those radio bearers that are configured to support lossless SRNS relocation. The Receive\_SN is only included when the UE receives a new U-RNTI.

The following parameters are used in the primitives:

- 1) PDCP info:
  - contains the parameters for each of the header compression algorithms configured to be used by one PDCP entity.
- 2) RLC-SAP:
  - the RLC-SAP (Tr/UM/AM) used by PDCP entity when communicating with RLC sublayer.
- 3) SN\_Sync:
  - Indicates that PDCP should start PDCP sequence number synchronization

## 4) Send\_SN:

- The send PDCP sequence number. There is one in the uplink and one in the downlink. Refer to subclause 5.4.1.

## 5) Receive\_SN:

- The receive PDCP sequence number. There is one in the uplink and one in the downlink. Refer to subclause 5.4.1.

## 6) PDCP SN:

- This includes a PDCP sequence number.

## 8 Elements for peer-to-peer communication

### 8.1 Protocol data units

Two different protocol data unit formats are defined in PDCP for Release 1999. This is configured for the PDCP entity by RRC with the information element, "PDCP PDU header" in *PDCP info*.

### 8.2 Formats

A PDCP PDU is byte-aligned, if the RLC is run on unacknowledged or acknowledged mode. Otherwise, in transparent mode, it is bit-aligned. In the drawings in subclause 8.2, bit strings are represented by tables in which the first bit is the leftmost one on the first line of the table, the last bit is the rightmost on the last line of the table, and more generally the bit string is to be read from left to right and then in the reading order of the lines.

SDUs are bit strings, with any nonnull length. If not compressed within PDCP an SDU is included from first bit onward.

#### 8.2.1 PDCP-No-Header PDU

The PDCP-No-Header PDU does not introduce any overhead to the PDCP SDU.

The format of the PDCP-No-Header-PDU is shown in table 4.

**Table 4: PDCP-No-Header PDU**

Data
------

#### 8.2.2 PDCP Data PDU

The data PDU is used to convey a payload unit containing a PDCP SDU, header compression related control signalling or data that has been obtained from PDCP SDU after header compression.

The format of the PDCP-Data-PDU is shown in table 5.

**Table 5: PDCP-Data-PDU format**

PDU type	PID
Data	

## 8.2.3 PDCP SeqNum PDU

The sequence number PDU is used to convey a payload unit containing a PDCP PDU sequence number and PDCP SDU, header compression related control signalling or data that has been obtained from PDCP SDU after header compression.

The format of the PDCP-SeqNum-PDU is shown in table 6.

**Table 6: PDCP-SeqNum-PDU format**

PDU type	PID
Sequence number	
Data	

## 8.3 Parameters

If not otherwise mentioned in the definition of each field then the bits in the parameters shall be interpreted as follows: the left most bit string is the first and most significant and the right most bit is the last and least significant bit.

Unless otherwise mentioned, integers are encoded in standard binary encoding for unsigned integers. In all cases the bits appear ordered from MSB to LSB when read in the PDU.

### 8.3.1 PDU Type

Length: 3 bits.

The PDU type field indicates the PDCP-data-PDU type.

Bit	PDU Type
<b>000</b>	PID field used for header compression information (PDCP-PDU format described in table 5)
<b>001</b>	PID field used for header compression information and the PDCP PDU sequence number included (PDCP-PDU format described in table 6)
<b>010-111</b>	Reserved (PDUs with this encoding are invalid for this version of the protocol)

### 8.3.2 PID

Length: 5 bits.

The PID type field indicates the used header compression and packet type.

Bit	Description
<b>00000</b>	No header compression
<b>00001-11111</b>	Dynamically negotiated header compression identifier, as described in subclause 5.1.1

PID field value defines used header compression type and packet type. One compression algorithm may reserve a certain amount of values from PID field value space for different packet types. Receiving PDCP makes reverse operation (e.g. header decompression) according to PID field value. There is not fixed relation between PID field value and used optimization / packet type, but PID field values are defined dynamically at the PDCP parameter negotiation.

### 8.3.3 Data

PDCP SDUs that have been header compressed, as described in RFC 2507 for 1999, are mapped to this field if header compression is negotiated. Otherwise, PDCP SDUs are mapped to this field.

### 8.3.4 Sequence number

Length: 16 bits

PDCP PDU sequence number.

---

## 9 Handling of unknown, unforeseen and erroneous protocol data

In case of error situations the following action is foreseen:

- 1) PDCP entity should discard invalid PDU.

## Annex A (informative): Change history

Change history					
TSG-RAN#	Version	CR	Tdoc RAN	New Version	Subject/Comment
RAN_06	-	-	RP-99645	3.0.0	(12/99) Approved at TSG-RAN #6 and placed under Change Control
RAN_07	3.0.0	004	RP-000041	3.1.0	(03/00) Bit order of PDCP PDUs
RAN_07	3.0.0	005	RP-000041	3.1.0	Changes to PDCP
RAN_08	3.1.0	006	RP-000221	3.2.0	(06/00) Changes in PDCP PDU format due to PDCP sequence numbering
RAN_09	3.2.0	009	RP-000359	3.3.0	(09/00) Clarification of PDCP Sequence Numbering
RAN_09	3.2.0	011	RP-000359	3.3.0	Clarification on how to handle invalid PDUs
RAN_09	3.2.0	012	RP-000359	3.3.0	Primitives required for SRNS relocation
RAN_09	3.2.0	015	RP-000359	3.3.0	Handling of invalid PDCP PDU sequence number