

JF-AF0084.00  
LANエミュレーションバージョン 2.0  
LUNI 仕様

[ LAN Emulation Over ATM Version 2 - LUNI Specification ]

TTC標準 第1版 1998年4月28日制定

TTC標準 補遺 第1版 1998年6月2日制定

社団法人  
情報通信技術委員会

THE TELECOMMUNICATION TECHNOLOGY COMMITTEE

本書は、(社)情報通信技術委員会が著作権を保有しています。  
内容の一部又は全部を(社)情報通信技術委員会の許諾を得ることなく複製、転載、改変、  
転用及びネットワーク上での送信、配布を行うことを禁止します。

<参考>

1．英文記述の適用レベル

適用レベル：E 3

本標準の本文または付録の文章あるいは図表に英文記述を含んでいる。

2．国際勧告との関連

本標準は The ATM Forum において、1997 年 7 月に制定された仕様 af-lane-0084.000:LAN Emulation Over ATM Version 2 - LUNI Specification に基づいて定めたものである。

3．上記国際勧告等に対する追加項目等

3．1 オプション選択項目

なし

3．2 ナショナルマター決定項目

なし

3．3 先行している項目

なし

3．4 追加した項目

なし

3．5 削除した項目

なし

3．6 国際勧告に対する修正内容

なし

4．改版の履歴

版数	制定日	改版内容
第 1 版	1998 年 4 月 28 日	制定

## 5 . 工業所有権

本標準に関わる「工業所有権等の実施の権利に係る確認書」の提出状況は、TTCホームページでご覧になれます。

## 6 . その他

### (1)参照勧告、標準、仕様等

The ATM Forum Specification :

af-uni-0010.001:ATM User-Network Interface Specification, Version3.0

af-uni-0010.002:ATM User-Network Interface Specification, Version3.1

af-sig-0061.000:UNI Signaling 4.0

## 目次

1	序	15
1.1	背景	15
1.2	エミュレーションされる LAN の特性	15
1.3	増強された LAN エミュレーションのサービス	16
1.4	用語と記述上の取り決め	16
1.5	参考文献	18
1.6	前提とする ATM ネットワークサービス	19
2	LAN エミュレーションサービスの記述	20
2.1	アーキテクチャー概要	20
2.1.1	基本コンセプト	20
2.1.2	アーキテクチャー上の見通し	20
2.1.3	実装上の見通し	23
2.2	LAN エミュレーションのコンポーネント	23
2.2.1	LE クライアント (LEC)	24
2.2.2	LE サーバ (LES)	24
2.2.3	ブロードキャストアンノウンサーバ (BUS)	24
2.2.4	LE コンフィグレーションサーバ (LECS)	24
2.3	LAN エミュレーションのコネクション	24
2.3.1	定義される VCC とフロー	25
2.3.2	フローの確立	25
2.3.3	フローと VCC の終端	25
2.3.4	コントロールフローおよび VCC	25
2.3.5	データフローおよび VCC	27
2.4	LAN エミュレーションサービスの機能	29
2.4.1	初期化	29
2.4.2	登録	30
2.4.3	アドレス解決	30
2.4.4	コネクション管理	31
2.4.5	通信品質 (QoS) の考察	31
2.4.6	データ転送	32
2.4.7	フレーム順序	33

2.4.8	ソースルーティングの考察	33
3	LAN エミュレーションサービス規定	34
3.1	LE から上位レイヤへのサービス	34
3.1.1	LE_UNITDATA.request	34
3.1.2	LE_UNITDATA.indication	34
3.1.3	LE_RESOLVE.request	35
3.1.4	LE_ASSOCIATE.request	35
3.1.5	LE_ASSOCIATE.indication	36
3.1.6	上位レイヤサービスへの QoS のインターフェース	36
3.2	LAN エミュレーションから AAL へのサービス	39
3.2.1	AAL_UNITDATA.request	39
3.2.2	AAL_UNITDATA.indication	39
3.3	コネクション管理サービス	39
3.3.1	非多重コネクション	40
3.3.2	LLC 多重コネクション	40
3.3.3	SVC	40
3.4	LEN エミュレーションからレイヤ管理部へのサービス	47
3.4.1	LE クライアントのレイヤ管理サービス	47
4	LAN エミュレーションのフレームフォーマット	51
4.1	LE データフレーム	51
4.1.1	イーサネット / IEEE 802.3 タイプ / 長さフィールドの符号化	53
4.2	LE コントロールフレーム	53
4.3	コントロールフレームの用法	57
4.3.1	無効なフレームの破棄	57
4.3.2	LANE LLC 多重ヘッダの送信	58
4.3.3	Request/Response フィールドの用法	58
4.3.4	FRAGS フィールドの用法	58
4.3.5	Sender/Receiver フィールドの用法	58
4.3.6	応答フレームの経路	58
4.3.7	応答フレームの着信先的一致	58
4.3.8	要求フレームの送信元の表示	59
4.3.9	応答フレームのフィルタリング	59
4.3.10	ELAN-ID のフィルタリング	59

4.3.11	要求 / 応答中の TLV .....	59
4.3.12	フォーマットが異常な TLV .....	59
4.3.13	OP-CODE の要約 .....	60
4.4	バイトおよびビットの順序 .....	60
4.5	MAC アドレスのメディアごとのフォーマット .....	61
5	初期化のプロトコル、処理およびフレームフォーマット .....	63
5.1	初期化状態 .....	63
5.1.1	初期化状態 - LE クライアントの観点から .....	63
5.1.2	初期化状態 - LE サービスの観点から .....	67
5.2	LECS 接続フェーズ .....	68
5.2.1	LECS 接続フェーズ - LE クライアントの観点から .....	68
5.2.2	LECS 接続フェーズ - LE サービスの観点から .....	69
5.3	コンフィグレーションフェーズ .....	69
5.3.1	コンフィグレーション - 要求元の観点から .....	70
5.3.2	コンフィグレーション - LE サービスの観点から .....	72
5.3.3	コンフィグレーションフレーム .....	74
5.3.4	コンフィグレーション要求フレーム - サポートされる TLV .....	75
5.3.5	コンフィグレーション応答フレーム - サポートされる TLV .....	76
5.4	ジョインフェーズ .....	77
5.4.1	ジョインフェーズ - LE クライアントの観点から .....	77
5.4.2	ジョインフェーズ - LE サービスの観点から .....	79
5.4.3	ジョインフレーム .....	82
5.4.4	ジョイン要求 - サポートされる TLV .....	83
5.4.5	ジョイン応答 - サポートされる TLV .....	83
5.5	初期化中の登録 .....	84
5.6	BUS 接続のプロトコルと処理 .....	84
5.6.1	プロトコル .....	84
6	登録のプロトコル、処理およびフレームフォーマット .....	87
6.1	登録の処理 .....	87
6.1.1	登録 - LE クライアントの観点から .....	87
6.1.2	登録 - LE サービスの観点から .....	89
6.2	登録フレーム .....	90
6.2.1	登録要求フレーム - サポートされる TLV .....	91

7	アドレス解決のプロトコル、処理およびフレームフォーマット.....	92
7.1	アドレス解決 - LE クライアントの観点から .....	92
7.1.1	コントロールダイレクト VCC 上でのアドレス解決.....	92
7.1.2	アドレス解決フレームの受付.....	92
7.1.3	ジョイン前のフレームの無視.....	92
7.1.4	マルチキャスト MAC アドレスに対する LE_ARP_REQUEST の送信.....	92
7.1.5	LAN 宛先に対する LE_ARP_REQUEST への応答 .....	92
7.1.6	ローカルの LAN 宛先.....	93
7.1.7	リモートの LAN 宛先.....	93
7.1.8	LLC 多重および非多重の ATM アドレス.....	93
7.1.9	LE_ARP_REQUEST 中の ATM アドレスの選択 .....	93
7.1.10	LE_ARP_RESPONSE 中の ATM アドレスの選択.....	93
7.1.11	サービスカテゴリ TLV.....	93
7.1.12	ブロードキャストおよびアンノウン LAN 宛先のための BUS の ATM アドレスの取得	93
7.1.13	未解決の LAN 宛先への送信.....	93
7.1.14	コネクションの確立 .....	93
7.1.15	B-LLI のコードポイント.....	93
7.1.16	LE_ARP_REQUEST の頻度.....	94
7.1.17	LE_ARP キャッシュ .....	94
7.1.18	LE_ARP キャッシュのエントリの対照.....	94
7.1.19	LE_ARP キャッシュの削除 .....	94
7.1.20	エージング時間 .....	94
7.1.21	LE_ARP_REQUEST 再試行の最大数 .....	94
7.1.22	LE_ARP キャッシュからのマルチキャストエントリの除外.....	94
7.1.23	トポロジチェンジフラグ (C19) .....	94
7.1.24	トポロジチェンジフラグの更新 (C19) .....	95
7.1.25	LE_TOPOLOGY_REQUEST の生成 .....	95
7.1.26	ローカル管理部からの指示 .....	95
7.1.27	スパニングツリーのコンフィグレーション BPDU.....	95
7.1.28	未解決の LE_ARP_REQUEST .....	95
7.1.29	バージョン 1 の LE_NARP_REQUEST .....	95
7.1.30	ターゲットの存在しない LE_ARP_REQUEST .....	96
7.1.31	送信元のない LE_NARP_REQUEST .....	96



7.1.32	LE_NARP とターゲットの存在しない LE_ARP の時間制限.....	96
7.1.33	LE_NARP_REQUEST とターゲットの存在しない LE_ARP_REQUEST およびトポロジ エンジンジ .....	96
7.1.34	ローカルでの対応のための LE_NARP_REQUEST .....	96
7.1.35	LE_ARP キャッシュの更新 .....	96
7.1.36	新規の LE_ARP キャッシュエントリの学習 .....	97
7.2	アドレス解決 - LE サービスの観点から .....	97
7.2.1	アドレス解決の VCC .....	97
7.2.2	LE_ARP_REQUEST と LE_ARP_RESPONSE の送信 .....	97
7.2.3	既知のユニキャスト LAN 宛先に対する LE_ARP_REQUEST への応答 .....	97
7.2.4	解決できない LE_ARP_REQUEST への応答禁止 .....	97
7.2.5	解決できる LE_ARP_REQUEST の転送禁止 .....	97
7.2.6	マルチキャスト MAC アドレスに対する LE_ARP_REQUEST への応答 .....	97
7.2.7	LE_NARP_REQUEST とターゲットの存在しない LE_ARP_REQUEST の転送 .....	98
7.2.8	LE_ARP_REQUEST の転送 .....	98
7.2.9	プロキシ LE クライアントへの LE_ARP_REQUEST の転送 .....	98
7.2.10	ブロードキャスト LAN 宛先に対する LE_ARP_REQUEST への応答 .....	98
7.2.11	LE_TOPOLOGY_REQUEST の転送 .....	98
7.2.12	LE_TOPOLOGY_REQUEST の起動 .....	98
7.3	アドレス解決フレーム .....	99
7.3.1	LE_ARP でサポートされる TLV .....	100
7.4	LE_NARP フレームフォーマット .....	100
7.4.1	LE_NARP でサポートされる TLV .....	101
7.5	トポロジチェンジフレーム .....	101
8	データ転送の Protokol と処理 .....	102
8.1	データ転送フェーズ - LE クライアントの Protokol メカニズム .....	102
8.1.1	データフレーム VCC .....	102
8.1.2	データフレームの頻度 .....	102
8.1.3	LECID の用法 .....	102
8.1.4	LECID に基づくフレームの破棄 .....	102
8.1.5	ELAN-ID に基づくフレームの破棄 .....	102
8.1.6	最大フレーム長 .....	102
8.1.7	データフレームの転送 .....	102

8.1.8	データフレームのフィルタリング	103
8.1.9	IEEE 802.3 データフレームの最短長	103
8.1.10	IEEE 802.5 データフレームの最短長	103
8.1.11	最大データフレーム長 (C3)	103
8.1.12	B-LLI の値が不正な VCC の拒否	103
8.1.13	重複して受け付けたデータダイレクト VCC	103
8.1.14	データダイレクト VCC の終端	103
8.1.15	ELAN メンバーシップの終端	103
8.2	データダイレクト用呼の確立	104
8.2.1	データダイレクト VCC に対するサービスカテゴリの選択	104
8.2.2	クライアントの受信可能フレーム	104
8.2.3	LLC 多重か非多重かの選択	104
8.2.4	CONNECT メッセージを受信した際の発呼側クライアントの動作	104
8.2.5	着呼側クライアントのタイマー C28 の終了	104
8.3	データ転送フェーズ - BUS のプロトコルメカニズム	104
8.3.1	最大フレームエイジ S5	104
8.3.2	BUS のユニキャストデータフレームの転送	104
8.3.3	BUS のブロードキャストデータフレームの転送	104
8.3.4	BUS のマルチキャストデータフレームの転送	105
8.3.5	BUS のトークンリング ARE および STE フレームの転送	105
8.3.6	マルチキャストフォワードあるいはマルチキャストセンド VCC の選択	105
8.4	データ転送フェーズ - LES のプロトコルメカニズム	105
8.4.1	LE サーバによる VCC 解放の検出と ELAN メンバーシップの終端	105
8.4.2	LE サーバによる ELAN メンバーシップの終端	105
8.5	トークンリングフレームの配信	105
8.5.1	ブリッジの LE_NARP への応答	105
8.5.2	NSR フレーム	106
8.5.3	マルチキャストフレーム	106
8.5.4	ARE、STE フレーム	106
8.5.5	RI フィールド長	106
8.5.6	不正な RI フィールド	106
8.5.7	無ホップ	106
8.5.8	同一の ELAN 上の最終ホップ	106

8.5.9	次の RD.....	106
8.6	最大データフレーム長.....	107
9	ベリファイのプロトコル、処理およびフレームフォーマット.....	109
9.1	対照の処理.....	109
9.1.1	対照 - LE クライアントの観点から.....	109
9.1.2	対照 - LE サーバの観点から.....	110
9.2	ベリファイフレーム.....	110
10	フラッシュメッセージのプロトコル、処理およびフレームフォーマット.....	111
10.1	フラッシュメッセージプロトコルおよび処理.....	111
10.1.1	必須なプロトコル.....	111
10.1.2	オプションのプロトコル.....	112
10.1.3	マルチキャスト.....	113
10.2	フラッシュフレーム.....	114
11	ターミネーションのプロトコルおよび処理.....	116
11.1	ターミネーション - LE クライアントの観点から.....	116
11.1.1	コントロールおよびマルチキャストデータ VCC の解放.....	116
11.1.2	共有する VCC.....	116
11.1.3	データダイレクト VCC の解放.....	116
11.1.4	LE クライアントのコンフィグレーションフェーズへの復帰.....	116
11.1.5	LES との接続の再確立.....	116
11.2	ターミネーション - LE サービスの観点から.....	116
11.2.1	LE サーバと BUS の動作.....	116
11.2.2	VCC の再確立.....	117
11.2.3	LE クライアントがサービスを拒否もしくはターミネーションされる可能性.....	117
12	ATM アドレスの用法.....	118
12.1	ATM アドレスの用法の要約.....	118
12.2	LE クライアントの ATM アドレス.....	119
12.2.1	プライマリ ATM アドレス.....	119
12.2.2	プライマリ ATM アドレスの用法.....	120
12.2.3	固有の ATM アドレス.....	120
12.2.4	共有される ATM アドレス.....	120
12.3	LE サーバの ATM アドレス.....	120
12.3.1	必要とされる ATM アドレス.....	120

12.3.2	ATM アドレスの共有 .....	120
12.3.3	共有される ATM アドレスが有効でない場合 .....	120
12.4	ブロードキャストアンノウンサーバの ATM アドレス .....	120
12.4.1	必要とされる BUS の ATM アドレス .....	120
12.4.2	ATM アドレスの共有 .....	120
12.4.3	共有される ATM アドレスが有効でない場合 .....	121
12.5	LE コンフィグレーションサーバの ATM アドレス .....	121
12.5.1	必要とされる ATM アドレス .....	121
12.5.2	ATM アドレスの共有 .....	121
12.5.3	共有される ATM アドレスが有効でない場合 .....	121
ANNEX A	LAN エミュレーションコントロールフレームの TLV .....	122
ANNEX B	コネクション設定の処理 .....	124
B.1	プロトコル概要 .....	124
B.2	READY_IND / READY_QUERY プロトコル .....	124
B.2.1	CONNECT メッセージを受信した場合の発呼側クライアントの動作 .....	125
B.2.2	着呼側クライアントの C28 の終端 .....	125
B.2.3	着呼側クライアントのタイマー-C28 の終了 .....	125
B.2.4	READY_QUERY に対する READY_IND 応答 .....	125
B.2.5	レディフレームフォーマット .....	125
APPENDIX A	LAN エミュレーションの状態遷移図の記述 .....	126
A.1	LE クライアント状態遷移図 .....	126
A.2	登録の状態遷移図 .....	134
A.3	LAN 宛先の状態遷移図 .....	136
APPENDIX B	特記事項 .....	142
B.1	最大フレーム長の計算 .....	142
B.2	トークンリングのソースルーティング情報と構造 .....	143
B.2.1	ルーティング情報フィールドの存在の判断 .....	143
B.2.2	ルーティング情報 (RI) フィールドのフォーマット .....	144
B.2.3	"Next_RD" の決定 .....	146
B.3	FDDI LAN との相互運用 .....	146
APPENDIX C	ネットワーク管理の考察 .....	150
APPENDIX D	LANE V2 の新しい特徴 .....	151
D.1	LAN V2 の特徴の要約 .....	151

D.2	MPOA からの要求事項.....	151
D.3	LANE V1 と LANE V2 の相互運用性.....	151
D.3.1	LANE V1 サービスコンポーネントと LANE V2 の共存 .....	151
D.3.2	LANE V1 クライアントと LANE V2 の共存.....	152
D.3.3	LANE V1 クライアントと LANE V2 クライアントの混在.....	152
APPENDIX E	ISO 10747 の要約 .....	153

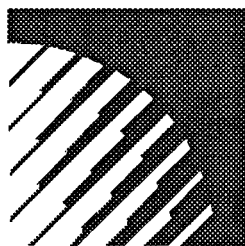

**The ATM Forum**  
**Technical Committee**

**LAN Emulation Over ATM**  
**Version 2 - LUNI Specification**

**AF-LANE-0084.000**

**July 1997**

© 1997 The ATM Forum. All Rights Reserved. No part of this publication may be reproduced in any form or by any means.

The information in this publication is believed to be accurate as of its publication date. Such information is subject to change without notice and The ATM Forum is not responsible for any errors. The ATM Forum does not assume any responsibility to update or correct any information in this publication. Notwithstanding anything to the contrary, neither The ATM Forum nor the publisher make any representation or warranty, expressed or implied, concerning the completeness, accuracy, or applicability of any information contained in this publication. No liability of any kind shall be assumed by The ATM Forum or the publisher as a result of reliance upon any information contained in this publication.

The receipt or any use of this document or its contents does not in any way create by implication or otherwise:

- Any express or implied license or right to or under any ATM Forum member company's patent, copyright, trademark or trade secret rights which are or may be associated with the ideas, techniques, concepts or expressions contained herein; nor
- Any warranty or representation that any ATM Forum member companies will announce any product(s) and/or service(s) related thereto, or if such announcements are made, that such announced product(s) and/or service(s) embody any or all of the ideas, technologies, or concepts contained herein; nor
- Any form of relationship between any ATM Forum member companies and the recipient or user of this document.

Implementation or use of specific ATM standards or recommendations and ATM Forum specifications will be voluntary, and no company shall agree or be obliged to implement them by virtue of participation in The ATM Forum.

The ATM Forum is a non-profit international organization accelerating industry cooperation on ATM technology. The ATM Forum does not, expressly or otherwise, endorse or promote any specific products or services.

NOTE: The user's attention is called to the possibility that implementation of the ATM interoperability specification contained herein may require use of an invention covered by patent rights held by ATM Forum Member companies or others. By publication of this ATM interoperability specification, no position is taken by The ATM Forum with respect to validity of any patent claims or of any patent rights related thereto or the ability to obtain the license to use such rights. ATM Forum Member companies agree to grant licenses under the relevant patents they own on reasonable and nondiscriminatory terms and conditions to applicants desiring to obtain such a license. For additional information contact:

The ATM Forum  
Worldwide Headquarters  
2570 West El Camino Real, Suite 304  
Mountain View, CA 94040-1313  
Tel: +1-415-949-6700  
Fax: +1-415-949-6705

## Acknowledgment

The contributions adopted by the ATM Forum and the assistance by the editing group of the LAN Emulation Sub-working Group, who contributed text and reviewed the drafts of this document, was essential to the completion of this specification.

In particular, the editor would like to recognize the following members who made significant contributions to this effort:

Norm Finn  
Phil Weeks  
Andrew Smith  
Matt Squire  
Andrew Tylee  
Eric Gray  
Andre Fredette  
Bob Klessig  
Andrew Carter  
Eldad Bar-Eli

The assistance by these members and all who participated in the LAN Emulation Sub-working Group, especially chairman Keith McCloghrie is appreciated.

John D. Keene, Editor





<b>1. INTRODUCTION.....</b>	<b>15</b>
1.1 Background.....	15
1.2 LAN-Specific Characteristics To Be Emulated.....	15
1.3 Enhanced LAN Emulation Services.....	16
1.4 Terminology and Conventions.....	16
1.5 References.....	18
1.6 ATM Network Service Assumptions.....	19
<b>2. DESCRIPTION OF LAN EMULATION SERVICE.....</b>	<b>20</b>
2.1 Architectural Overview.....	20
2.1.1 Basic Concepts.....	20
2.1.2 Architectural Perspective.....	20
2.1.3 Implementation Perspective.....	23
2.2 LAN Emulation Components.....	23
2.2.1 LE Client (LEC).....	24
2.2.2 LE Server (LES).....	24
2.2.3 Broadcast and Unknown Server (BUS).....	24
2.2.4 LE Configuration Server (LECS).....	24
2.3 LAN Emulation Connections.....	24
2.3.1 VCCs and Flows Defined.....	25
2.3.2 Establishing Flows.....	25
2.3.3 Terminating Flows and VCCs.....	25
2.3.4 Control Flows and VCCs.....	25
2.3.5 Data Flows and VCCs.....	27
2.4 Functions of the LAN Emulation Service.....	29
2.4.1 Initialization.....	29
2.4.2 Registration.....	30
2.4.3 Address Resolution.....	30
2.4.4 Connection Management.....	31
2.4.5 Quality of Service Considerations.....	31
2.4.6 Data Transfer.....	32
1.1.7 Frame Ordering.....	33
1.1.8 Source Routing Considerations.....	33
<b>3. LAN EMULATION SERVICE SPECIFICATION.....</b>	<b>34</b>
3.1 LE to Higher Layer Services.....	34
3.1.1 LE_UNITDATA.request.....	34
3.1.2 LE_UNITDATA.indication.....	34
3.1.3 LE_RESOLVE.request.....	35
3.1.4 LE_ASSOCIATE.request.....	35
3.1.5 LE_ASSOCIATE.indication.....	36
3.1.6 Quality of Service Interface to Higher Layer Services.....	36
3.2 LAN Emulation to AAL Services.....	39

3.2.1 AAL\_UNITDATA.request..... 39

3.2.2 AAL\_UNITDATA.indication ..... 39

**3.3 Connection Management Services..... 39**

3.3.1 Non-Multiplexed Connections..... 40

3.3.2 LLC-Multiplexed Connections..... 40

3.3.3 Switched Virtual Circuits (SVCs)..... 40

**3.4 LAN Emulation to Layer Management Services ..... 47**

3.4.1 LE Client Layer Management service..... 47

**4. LAN EMULATION FRAME FORMATS ..... 51**

**4.1 LE Data Frame ..... 51**

4.1.1 Encoding of Ethernet/IEEE 802.3 Type/Length Fields..... 53

**4.2 LE Control Frames..... 53**

**4.3 Control Frame Usage ..... 57**

4.3.1 Discarding Invalid Frames ..... 57

4.3.2 Transmitting the LANE LLC-Multiplexed Header ..... 58

4.3.3 Request/Response Field Usage..... 58

4.3.4 FLAGS Field Usage..... 58

4.3.5 Sender/Receiver Field Usage..... 58

4.3.6 Response Frame Routing ..... 58

4.3.7 Agreement of Response Frame Destinations..... 58

4.3.8 Request Frame Source Identification ..... 59

4.3.9 Response Frame Filtering..... 59

4.3.10 ELAN-ID Filtering..... 59

4.3.11 TLVs in Requests/Responses..... 59

4.3.12 Badly-Formatted TLVs ..... 59

4.3.13 Summary of OP-CODES ..... 60

**4.4 Byte and Bit Order ..... 60**

**4.5 Media Format of MAC Addresses..... 61**

**5. INITIALIZATION PROTOCOLS, PROCEDURES AND FRAME FORMATS ..... 63**

**5.1 Initial State ..... 63**

5.1.1 Initial State - LE Client View ..... 63

5.1.2 Initial State - LE Service View ..... 67

**5.2 LECS Connect Phase..... 68**

5.2.1 LECS Connect - LE Client View..... 68

5.2.2 LECS Connect - LE Service view..... 69

**5.3 Configuration Phase ..... 69**

5.3.1 Configuration - Requester's View ..... 70

5.3.2 Configuration - LE Service View ..... 72

5.3.3 Configuration Frames ..... 74

5.3.4 Configuration Request Frame - Supported TLVs ..... 75

5.3.5 Configuration Response Frame - Supported TLVs..... 76

**5.4 Join Phase ..... 77**

5.4.1 Join Phase - LE Client View..... 77

5.4.2 Join phase - LE Server View ..... 79

5.4.3 Join Frames ..... 82

5.4.4 Join Request Supported TLVs ..... 83

5.4.5 Join Response - Supported TLVs ..... 83

5.5 Registration During Initialization ..... 84

5.6 Connecting to the BUS Protocol and Procedures ..... 84

    5.6.1 Protocol ..... 84

**6. REGISTRATION PROTOCOL, PROCEDURES AND FRAME FORMATS ..... 87**

6.1 Registration Procedures ..... 87

    6.1.1 Registration - LE Client View ..... 87

    6.1.2 Registration - LE Server View ..... 89

6.2 Registration Frames ..... 90

    6.2.1 Register Request Frame - Supported TLVs ..... 91

**7. ADDRESS RESOLUTION PROTOCOL, PROCEDURES AND FRAME FORMATS**

**92**

7.1 Address Resolution - LE Client View ..... 92

    7.1.1 Address Resolution Over Control Direct VCC ..... 92

    7.1.2 Accepting Address Resolution Frames ..... 92

    7.1.3 Ignoring Frames Prior to Joining ..... 92

    7.1.4 Sending LE\_ARP\_REQUESTs for Multicast MAC Addresses ..... 92

    7.1.5 Responding to LE\_ARP\_REQUESTs for LAN Destinations ..... 92

    7.1.6 Local LAN Destinations ..... 93

    7.1.7 Remote LAN Destinations ..... 93

    7.1.8 LLC-Multiplexed and Non-Multiplexed ATM Addresses ..... 93

    7.1.9 Choice of ATM Address in LE\_ARP\_REQUEST ..... 93

    7.1.10 Choice of ATM Address in LE\_ARP\_RESPONSE ..... 93

    7.1.11 Service-Category TLV ..... 93

    7.1.12 Obtaining BUS ATM Address for Broadcasts and Unknown LAN Destinations ..... 93

    7.1.13 Transmitting to Unresolved LAN Destination ..... 93

    7.1.14 Establishing Connections ..... 93

    7.1.15 B-LLI Code Points ..... 93

    7.1.16 LE\_ARP\_REQUEST Frequency ..... 94

    7.1.17 LE\_ARP Cache (C16) ..... 94

    7.1.18 Verifying LE\_ARP Cache Entries ..... 94

    7.1.19 Elimination of LE\_ARP Cache Entries ..... 94

    7.1.20 Aging Time ..... 94

    7.1.21 LE\_ARP\_REQUEST Maximum Retries ..... 94

    7.1.22 Removing Multicast Entries from LE\_ARP Cache ..... 94

    7.1.23 Topology Change Flag (C19) ..... 94

    7.1.24 Updating Topology Change Flag (C19) ..... 95

    7.1.25 Generation of LE\_TOPOLOGY\_REQUESTs ..... 95

    7.1.26 Local Management Directives ..... 95

    7.1.27 Spanning Tree Configuration BPDUs ..... 95

    7.1.28 Unresolved LE\_ARP\_REQUESTs ..... 95

    7.1.29 Version 1 LE\_NARP\_REQUEST ..... 95

    7.1.30 Targetless LE\_ARP\_REQUEST ..... 96

    7.1.31 No-source LE\_NARP\_REQUEST ..... 96

    7.1.32 LE\_NARP and Targetless LE\_ARP Time Limits ..... 96

    7.1.33 LE\_NARP\_REQUESTs and Targetless LE\_ARP\_REQUESTs and Topology Changes ..... 96

    7.1.34 LE\_NARP\_REQUESTs For Local Bindings ..... 96

    7.1.35 Updating the LE\_ARP Cache ..... 96

7.1.36 Learning New LE_ARP Cache Entries .....	97
<b>7.2 Address Resolution - LE Service View .....</b>	<b>97</b>
7.2.1 Address Resolution VCC .....	97
7.2.2 Transmitting LE_ARP_REQUESTs and LE_ARP_RESPONSEs.....	97
7.2.3 Responding to LE_ARP_REQUESTs for Known Unicast LAN Destinations.....	97
7.2.4 Not Responding to Unknown LE_ARP_REQUESTs .....	97
7.2.5 Not Forwarding Known LE_ARP_REQUESTs .....	97
7.2.6 Responding to LE_ARP_REQUESTs for Multicast MAC Addresses.....	97
7.2.7 Forwarding LE_NARP_REQUESTs and Targetless LE_ARP_REQUESTs.....	98
7.2.8 Forwarding LE_ARP_REQUESTs.....	98
7.2.9 Forwarding LE_ARP_REQUESTs to Proxy LE Clients.....	98
7.2.10 Responding to LE_ARP_REQUESTs for Broadcast LAN Destination .....	98
7.2.11 Forwarding LE_TOPOLOGY_REQUESTs.....	98
7.2.12 Initiating LE_TOPOLOGY_REQUESTs.....	98
<b>7.3 Address Resolution Frames.....</b>	<b>99</b>
7.3.1 LE_ARP Supported TLVs.....	100
<b>7.4 LE_NARP Frame Format .....</b>	<b>100</b>
7.4.1 LE-NARP Supported TLVs.....	101
<b>7.5 Topology Change Frames.....</b>	<b>101</b>
<b>8. DATA TRANSFER PROTOCOL AND PROCEDURES.....</b>	<b>102</b>
<b>8.1 Data Transfer Phase - LE Client Protocol Mechanisms .....</b>	<b>102</b>
8.1.1 Data Frame VCC .....	102
8.1.2 Data Frame Frequency .....	102
8.1.3 Use of LECID.....	102
8.1.4 Discarding Frames Based on LECID.....	102
8.1.5 Discarding Frames Based on ELAN-ID.....	102
8.1.6 Maximum Frame Sizes .....	102
8.1.7 Forwarding Data Frames .....	102
8.1.8 Filtering Data Frames.....	103
8.1.9 Minimum IEEE 802.3 Data Frame Size.....	103
8.1.10 Minimum IEEE 802.5 Data Frame Size.....	103
8.1.11 Maximum Data Frame Size (C3).....	103
8.1.12 Refusing VCCs with Incorrect B-LLI Values.....	103
8.1.13 Duplicate Incoming Data Direct VCC .....	103
8.1.14 Data Direct VCC Termination.....	103
8.1.15 Terminating ELAN Membership.....	103
<b>8.2 Data Direct Call Establishment.....</b>	<b>104</b>
8.2.1 Selecting Service Category for Data Direct VCCs .....	104
8.2.2 Client Ready to Receive Frames.....	104
8.2.3 Choice of LLC-Multiplexed or Non-Multiplexed VCC.....	104
8.2.4 Calling Client Action on Receiving CONNECT Message.....	104
8.2.5 Called Client Timer C28 Expires.....	104
<b>8.3 Data Transfer Phase - BUS Protocol Mechanisms.....</b>	<b>104</b>
8.3.1 Maximum Frame Age S5 .....	104
8.3.2 BUS Forwarding Unicast Data Frames .....	104
8.3.3 BUS Forwarding Broadcast Data Frames.....	104
8.3.4 BUS Forwarding Multicast Data Frames .....	105
8.3.5 BUS forwarding of Token Ring ARE and STE frames.....	105
8.3.6 Selection of Multicast Forward and Multicast Send VCCs .....	105

<b>8.4 Data Transfer Phase - LES Protocol Mechanisms</b> .....	<b>105</b>
8.4.1 LE Server Detects VCC Release and Terminates ELAN Membership .....	105
8.4.2 LE Server Terminates ELAN Membership .....	105
<b>8.5 Delivery of Token Ring Frames</b> .....	<b>105</b>
8.5.1 Bridge Response to LE_ARP .....	105
8.5.2 NSR Frames .....	106
8.5.3 Multicast Frames .....	106
8.5.4 ARE, STE Frames.....	106
8.5.5 RI Field Length.....	106
8.5.6 Invalid RI Field.....	106
8.5.7 No Hops .....	106
8.5.8 Last Hop on Same ELAN.....	106
8.5.9 Next RD .....	106
<b>8.6 Maximum Data Frame Size</b> .....	<b>107</b>
<b>9. VERIFY PROTOCOL, PROCEDURES AND FRAME FORMATS</b> .....	<b>109</b>
<b>9.1 Verification Procedures</b> .....	<b>109</b>
9.1.1 Verification - LE Client View .....	109
9.1.2 Verification - LE Server View.....	110
<b>9.2 Verify Frames</b> .....	<b>110</b>
<b>10. FLUSH MESSAGE PROTOCOL, PROCEDURES AND FRAME FORMATS</b> ...	<b>111</b>
<b>10.1 Flush Message Protocol and Procedures</b> .....	<b>111</b>
10.1.1 Mandatory Protocol.....	111
10.1.2 Optional Protocol.....	112
10.1.3 Multicast.....	113
<b>10.2 Flush Frames</b> .....	<b>114</b>
<b>11. TERMINATION PROTOCOL AND PROCEDURES</b> .....	<b>116</b>
<b>11.1 Termination - LE Client View</b> .....	<b>116</b>
11.1.1 Releasing Control and Multicast Data VCCs .....	116
11.1.2 Shared VCCs .....	116
11.1.3 Releasing Data Direct VCCs .....	116
11.1.4 LE Client Returns to Configuration Phase .....	116
11.1.5 Re-establishment of LES Connectivity .....	116
<b>11.2 Termination - LE Service View (LES or BUS)</b> .....	<b>116</b>
11.2.1 LE Server and BUS Actions .....	116
11.2.2 VCC Re-establishment.....	117
11.2.3 LE Client May Have Service Refused or Terminated .....	117
<b>12. USAGE OF ATM ADDRESSES</b> .....	<b>118</b>
<b>12.1 ATM Address Uses Summary</b> .....	<b>118</b>
<b>12.2 LE Client ATM Addresses</b> .....	<b>119</b>
12.2.1 Primary ATM Address .....	119
12.2.2 Use of Primary Address .....	120

12.2.3 Unique ATM Addresses .....	120
12.2.4 Shared ATM Addresses.....	120
<b>12.3 LE Server ATM Addresses.....</b>	<b>120</b>
12.3.1 ATM Address Required .....	120
12.3.2 Sharing ATM Address .....	120
12.3.3 When Sharing ATM Addresses is not valid .....	120
<b>12.4 Broadcast and Unknown Server ATM Addresses.....</b>	<b>120</b>
12.4.1 BUS ATM Address Required.....	120
12.4.2 Sharing an ATM Address.....	120
12.4.3 When Sharing ATM Addresses is not valid .....	121
<b>12.5 LE Configuration Server ATM Addresses.....</b>	<b>121</b>
12.5.1 ATM Address Required .....	121
12.5.2 Sharing an ATM Address.....	121
12.5.3 When Sharing ATM Address not valid .....	121
<b>ANNEX A LAN EMULATION CONTROL FRAME TLVS .....</b>	<b>122</b>
<b>ANNEX B CONNECTION SETUP PROCEDURE .....</b>	<b>124</b>
<b>B.1 Protocol Overview.....</b>	<b>124</b>
<b>B.2 READY_IND/READY_QUERY Protocol.....</b>	<b>124</b>
B.2.1 Calling Client Action on Receiving CONNECT Message.....	125
B.2.2 Called Client Terminates C28.....	125
B.2.3 Called Client Timer C28 Expires .....	125
B.2.4 READY_IND Response to READY_QUERY .....	125
B.2.5 Ready Frame Format.....	125
<b>APPENDIX A STATE MACHINE DESCRIPTION OF LAN EMULATION.....</b>	<b>126</b>
<b>A.1 The LE Client State Machines .....</b>	<b>126</b>
<b>A.2 Registration State Machines .....</b>	<b>134</b>
<b>A.3 The LAN Destination State Machines.....</b>	<b>136</b>
<b>APPENDIX B SPECIAL TOPICS .....</b>	<b>142</b>
<b>B.1 Maximum Frame Size Calculation .....</b>	<b>142</b>
<b>B.2 Token Ring Source Routing Information and Structures .....</b>	<b>143</b>
B.2.1 Determining if the Routing Information Field is Present.....	143
B.2.2 ROUTING INFORMATION (RI) FIELD Format .....	144
B.2.3 Determining the "Next_RD" .....	146
<b>B.3 Interworking with FDDI LANs.....</b>	<b>146</b>
<b>APPENDIX C NETWORK MANAGEMENT CONSIDERATIONS .....</b>	<b>150</b>
<b>APPENDIX D NEW LANE V2 FEATURES.....</b>	<b>151</b>

- D.1 Summary of LANE v2 Features..... 151
- D.2 MPOA Requirements..... 151
- D.3 Compatibility between LANEv1 and LANEv2..... 151
  - D.3.1 LANEv2 With LANEv1 LE Service Components ..... 151
  - D.3.2 LANE v2 With LANE v1 Clients..... 152
  - D.3.3 A Mixture of LANE v1 and LANE v2 Clients..... 152
  
- APPENDIX E SUMMARY OF ISO 10747..... 153



## List of Figures

FIGURE 1. THE LAYERED ARCHITECTURE OF LAN EMULATION	21
FIGURE 2. THE LAN EMULATION USER NETWORK INTERFACE (LUNI)	23
FIGURE 3. EXAMPLE OF LAN EMULATION CLIENT FLOWS ACROSS LUNI	25
FIGURE 4. LE CLIENT TO LAN EMULATION CONFIGURATION SERVER (LECS) CONTROL CONNECTION	26
FIGURE 5. LAN EMULATION CLIENT TO LAN EMULATION SERVER (LES) CONTROL CONNECTIONS	26
FIGURE 6. LAN EMULATION CLIENT TO CLIENT DATA CONNECTIONS	27
FIGURE 7. LAN EMULATION CLIENT BROADCAST/MULTICAST CONNECTIONS	28
FIGURE 8. INITIALIZATION, RECOVERY AND TERMINATING THE ELAN	30
FIGURE 9. CALL ESTABLISHMENT: READY INDICATE/QUERY	124
FIGURE 10. LE CLIENT STATE MACHINE (INITIALIZATION)	127
FIGURE 11. LE CLIENT STATE MACHINE (JOIN, LE_ARP)	130
FIGURE 12. LE CLIENT STATE MACHINE (OPERATIONAL)	132
FIGURE 13. REGISTRATION STATE MACHINES	135
FIGURE 14. LAN DESTINATION STATE MACHINES (PART 1)	137
FIGURE 15. LAN DESTINATION STATE MACHINE (PART 2)	139
FIGURE 16. LAN DESTINATION UNCONNECTED STATE MACHINE	141
FIGURE 17. SOURCE ADDRESS FIELD	144
FIGURE 18. ROUTING INFORMATION FIELD CONTENT	145
FIGURE 19. ROUTING INFORMATION FIELD FORMAT	145
FIGURE 20. ROUTE DESCRIPTOR FORMAT	146
FIGURE 21. EXTRACTING "NEXT_RD"	146
FIGURE 22. ISO 10747 ADDRESS FORMAT	153

## List of Tables

TABLE 1. NORMATIVE STATEMENTS	18
TABLE 2. AAL PARAMETERS	42
TABLE 3. ATM USER CELL RATE/ATM TRAFFIC DESCRIPTOR FOR UBR/ABR	43
TABLE 4. BROADBAND BEARER CAPABILITY FOR UBR/ABR	44
TABLE 5. BROADBAND LOW LAYER INFORMATION, NON-MULTIPLEXED VCCS	45
TABLE 6. BROADBAND LOW LAYER INFORMATION, LLC-MULTIPLEXED VCCS	45
TABLE 7. ATM TRAFFIC DESCRIPTOR IN CONNECT MESSAGE FOR UBR/ABR	46
TABLE 8. RELEASE, RELEASE COMPLETE AND DROP PARTY CAUSE CODES	46
TABLE 9. LAN EMULATION NON-MULTIPLEXED DATA FRAME FORMAT FOR IEEE 802.3/ETHERNET FRAMES	51
TABLE 10. LAN EMULATION LLC-MULTIPLEXED DATA FRAME FORMAT FOR IEEE 802.3/ETHERNET FRAMES	51
TABLE 11. LAN EMULATION NON-MULTIPLEXED DATA FRAME FORMAT FOR IEEE 802.5 FRAMES	52
TABLE 12. LAN EMULATION LLC-MULTIPLEXED DATA FRAME FORMAT FOR IEEE 802.5 FRAMES	52
TABLE 13. LANE CONTROL FRAME	54
TABLE 14. LANE LLC MULTIPLEXED CONTROL FRAME (FLUSH REQUEST ONLY)	54
TABLE 15. CONTROL FRAME HEADER FORMAT	55
TABLE 16. LAN DESTINATION FIELD FORMAT	55
TABLE 17. CONTROL FRAME FLAGS VALUES	55
TABLE 18. CONTROL FRAME STATUS VALUES	57
TABLE 19. OP-CODE SUMMARY	60
TABLE 20. FORMATS FOR IEEE 48 BIT MAC ADDRESS BASED ON LAN TYPE	62
TABLE 21. MAXIMUM-FRAME-SIZE V1/V2 ADJUSTMENT	70
TABLE 22. CONFIGURATION FRAME FORMAT	74
TABLE 23. CONFIGURATION REQUEST FRAME - SUPPORTED TLVS	76
TABLE 24. CONFIGURATION RESPONSE FRAME - SUPPORTED TLVS	76
TABLE 25. JOIN FRAME FORMAT	82
TABLE 26. JOIN REQUEST FRAME - SUPPORTED TLVS	83
TABLE 27. JOIN RESPONSE FRAME - SUPPORTED TLVS	84
TABLE 28. REGISTRATION FRAME FORMAT	91
TABLE 29. REGISTER REQUEST FRAME - SUPPORTED TLVS	91
TABLE 30. LE_ARP FRAME FORMAT	99
TABLE 31. LE_ARP FRAME - SUPPORTED TLVS	100
TABLE 32. LE_NARP FRAME FORMAT	100
TABLE 33. LE NARP REQUEST FRAME - SUPPORTED TLVS	101
TABLE 34. TOPOLOGY CHANGE FRAME FORMAT	101
TABLE 35. LAN DESTINATION OF TOKEN RING FRAMES	107

TABLE 36. LAN DESTINATION FOR UNICAST SRF TOKEN RING FRAMES	107
TABLE 37. MAXIMUM DATA FRAME SIZE	108
<b>TABLE 38. VERIFY FRAME FORMAT</b>	110
TABLE 39. FLUSH FRAME FORMAT	114
TABLE 40. ATM ADDRESS USES	118
TABLE 41. LAN EMULATION CONTROL FRAME TLVS	122
TABLE 42. READY FRAME FORMAT	125
TABLE 43. MAXIMUM FRAME SIZE CALCULATION	143
TABLE 44. SUMMARY OF LANE V2 FEATURES	151

# 1. Introduction

This document is one of two parts of LANE v2, the second revision of the LAN Emulation specification. This document describes the LAN Emulation User Network Interface (LUNI v2). It supercedes the LAN Emulation over ATM Specification Version 1.0 [23]. LUNI v2 provides enhanced capabilities including LLC multiplexing for VCC sharing, support for ABR and other qualities of service through an expanded service interface, enhanced multicast support and support for ATM Forum Multiprotocol Over ATM. A second document [16] describes the LAN Emulation Network Network Interface (LNNI) defining interfaces between the components of the LAN Emulation service, which were not addressed by [23].

## 1.1 Background

Most data traffic in existing Customer Premises Networks (CPNs) is sent over Local Area Networks (LANs), such as Ethernet/IEEE 802.3 and IEEE 802.5 networks. The services provided by today's LANs differ from those of ATM, for example:

1. The messages may be characterized as connectionless, versus the connection-oriented approach of ATM;
2. Broadcast and multicast are easily accomplished through the shared medium of a LAN;
3. LAN MAC addresses, based on manufacturing serial numbers, are independent of the network topology.

In order to use the vast base of existing LAN application software, the ATM Forum has defined an ATM service, herein called "LAN Emulation," that emulates services of existing LANs across an ATM network and can be supported via a software layer in end systems.

The LAN Emulation service enables end systems (e.g. workstations, servers, bridges, etc.) to connect to the ATM network while the software applications interact as if they are attached to a traditional LAN. Also, this service supports interconnection of ATM networks with traditional LANs by means of IEEE bridging methods. This allows interoperability between software applications residing on ATM-attached end systems and on traditional LAN end systems.

The LAN Emulation service has proven to be important to the acceptance of ATM, since it provides a simple and easy means for running existing LAN applications in the ATM environment. Networking customers demand coexistence with existing networks and that the transition to ATM be addressed. Current uses include ATM for work group LANs and LAN backbones. Customers expect to continue to use existing LAN applications as they migrate to ATM.

To emulate a LAN-like service, different types of emulation can be defined, ranging from emulating the MAC service (e.g. that of IEEE 802.x LANs) up to emulating the services of network and transport layers. LAN Emulation defines a MAC service emulation, including encapsulation of MAC frames (user data frames). This approach to LAN emulation provides support for the maximum number of existing applications.

## 1.2 LAN-Specific Characteristics To Be Emulated

### Connectionless Services

LAN stations today are able to send data without previously establishing connections. LAN Emulation provides the appearance of such a connectionless service to the participating end systems.

### Multicast Services

The LAN emulation service supports the use of multicast MAC addresses (e.g. broadcast, group, or functional MAC addresses). The need for a multicast service for LAN Emulation comes from classical LANs where end stations share the same media.

### MAC Driver Interfaces In ATM Stations

The main objective of the LAN emulation service is to enable existing applications to access an ATM network via protocol stacks like APPN, NetBIOS, IPX, AppleTalk etc. as if they were running over traditional LANs. Since in today's implementations these protocol stacks are communicating with a MAC driver, the LAN emulation service has to offer the same MAC driver service primitives, thus keeping the upper protocol layers unchanged.

There are today some "standardized" interfaces for MAC device drivers: e.g. NDIS (Network Driver Interface Specification)[2], ODI (Open Data-Link Interface)[3] and DLPI (Data Link Provider Interface)[18]. They specify how to access a MAC driver. Each of them has its own primitives and parameter sets, but the essential services/functions are the same. LAN Emulation provides these interfaces and services to the upper layers (see Section 3.1).

### Emulated LANs

In some environments there might be a need to configure multiple, separate domains within a single network. This requirement leads to the definition of an "emulated LAN" which comprises a group of ATM-attached devices. This group of devices would be logically analogous to a group of LAN stations attached to an Ethernet/IEEE 802.3 or 802.5 LAN segment.

Several emulated LANs (ELANs) could be configured within an ATM network, and membership in an emulated LAN is independent of where an end system is physically connected. An end system could belong to multiple emulated LANs.

Since multiple emulated LANs over a single ATM network are logically independent, a broadcast frame originating from a member of a particular emulated LAN is distributed only to the members of that emulated LAN.

### Interconnection With Existing LANs

As mentioned before, the LAN emulation service provides not only connectivity between ATM-attached end systems, but also connectivity with LAN-attached stations. This includes connectivity both from ATM stations to LAN stations as well as LAN stations to LAN stations across ATM. MAC layer LAN Emulation is defined in such a way that existing bridging methods can be employed, as they are defined today. Note that bridging methods include both Transparent Bridging and Source Routing Bridging[4].

## 1.3 Enhanced LAN Emulation Services

### Quality of Service

LANE v2 provides locally administered Quality of Service (QoS) for communication between ATM attached endsystems. Protocol mechanisms are provided to determine whether a remote endsystem is likely to support a desired QoS. Each locally defined QoS can include an indication of whether a VCC set up with that QoS may be shared with other protocols or applications.

### Enhanced Multicast

LANE v2 provides support for separating multicast traffic from the general broadcast path. Protocol mechanisms are provided to determine which members of the emulated LAN need to receive which multicast frames – e.g., not all members of the emulated LAN must receive all multicast frames. The filtering function is performed through cooperation between the source and the LAN Emulation service.

## 1.4 Terminology and Conventions

The following acronyms and terminology are used throughout this document:

AAL	ATM Adaptation Layer
ARE	All Routes Explorer
ATM	Asynchronous Transfer Mode
B-LLI	Broadband Low Layer Information
BN	Bridge Number
BPP	Bridge Port Pair (Source Routing Descriptor)
BPDU	Bridge Protocol Data Unit
BUS	Broadcast and Unknown Server
CPCS	Common Part Convergence Sublayer

CPN	Customer Premises Network
DA	Destination MAC address
ELAN	Emulated Local Area Network
IE	Information Element
IEEE	Institute of Electrical and Electronics Engineers
IETF	Internet Engineering Task Force
ILMI	Integrated Local Management Interface
IP	Internet Protocol
LAN	Local Area Network
LD	LAN Destination
LE	LAN Emulation
LE_ARP	LAN Emulation Address Resolution Protocol
LEC	LAN Emulation Client
LECID	LAN Emulation Client Identifier
LECS	LAN Emulation Configuration Server
LES	LAN Emulation Server
LLC	Logical Link Control [8]
LNNI	LAN Emulation Network Network Interface [16]
LSB	Least Significant Bit
LTH	Length Field
LUNI	LAN Emulation User Network Interface
MAC	Medium Access Control
MIB	Management Information Base
MSB	Most Significant Bit
MTU	Message Transfer Unit
NDIS	Network Driver Interface Specification
NSR	Non-Source Routed
ODI	Open Data-Link Interface
OSI	Open Systems Interconnection
OUI	Organizational Unit Identifier
PDU	Protocol Data Unit
QOS/QoS	Quality of Service
RC	Routing Control
RD	Route Descriptor
RFC	Request For Comment (Document Series)
RI	Routing Information
RII	Routing Information Indicator
RT	Routing Type
SA	Source MAC address

SAP	Service Access Point
SAAL	Signalling AAL
SDU	Service Data Unit
SMS	Selective Multicast Service
SR	Source Routing (Bridging)
SRF	Specifically Routed Frame
SRT	Source Routing Transparent
SSCS	Service Specific Convergence Sublayer
STE	Spanning Tree Explorer
TB	Transparent Bridging
TCP	Transmission Control Protocol
TLV	Type / Length / Value
UNI	User-Network Interface
VCC	Virtual Channel Connection
VPC	Virtual Path Connection
VCI	Virtual Channel Identifier
VPI	Virtual Path Identifier

This document uses normative statements throughout as follows:

**Table 1. Normative Statements**

Statement	Verbal Form <sup>1</sup>
Requirement	MUST/MUST NOT
Recommendation	SHOULD/SHOULD NOT
Permission	MAY <sup>2</sup>

## 1.5 References

- [2] 3COM/Microsoft, *LAN Manager: Network Driver Interface Specification*, October 8, 1990.
- [3] Novell Incorporated, *Open Data-Link Interface Developer's Guide*, March 20, 1992.
- [4] ISO/IEC 10038: ANSI/IEEE Std. 802.1D *Information processing systems - Local Area Networks - MAC Sublayer Interconnection (MAC Bridges)*.
- [5] The ATM Forum, *ATM User-Network Interface Specification, Version 3.0*, September 10, 1993.
- [7] ISO / IEC 10039 *Information technology - Telecommunications and information exchange between systems -Medium access control service definition*.

<sup>1</sup>Verbal forms are based on ISO except for "Requirements," where ISO uses the terms "SHALL/SHALL NOT" instead of "MUST/MUST NOT" in this document.

<sup>2</sup> The term "MAY" is used to indicate that a particular procedure is allowed but not required. It is an implementation choice. "MAY" is also used to indicate allowed behaviors that must be accommodated.

- [8] ISO 8802-2: ANSI/IEEE Std. 802.2 *Information processing systems - Local area networks - Part 2: Logical Link Control*.
- [14] ITU-T I.363.5 *ATM Adaptation Layer Type 5 Specification*..
- [15] *The Ethernet - A Local Area Network*, Digital Equipment Corporation, Intel, and Xerox, AA-K759B-TK, November, 1982.
- [16] The ATM Forum, *ATM LAN Emulation Network Network Interface (LNNI) Specification*, tbd.
- [17] The ATM Forum, *ATM User-Network Interface Version 3.1 (UNI 3.1) Specification*, af-uni-0010.002, 1994.
- [20] IETF, RFC 1577 Classical IP and ARP Over ATM, Network Working Group, January, 1994.
- [21] IETF, RFC 1626 Default IP MTU for use over AAL5, Network Working Group, May, 1994.
- [22] ISO, "Information Processing Systems - Telecommunications and Information Exchange between Systems - Protocol for Exchange of Inter-domain Routing Information among Intermediate Systems to Support Forwarding of ISO 8473 PDUs", ISO/IEC DIS 10747, August 1992.
- [23] The ATM Forum, *LAN Emulation Over ATM Version (LANE 1.0) 1.0 Specification*, af-lane-0021.000, 1995
- [24] The ATM Forum, *Integrated Local Management Interface Version 4.0 (ILMI 4.0) Specification*, af-ilmi-0065.000, 1996
- [25] The ATM Forum, *UNI Signalling Version 4.0 Specification*, af-sig-0061.000, 1996
- [27] IETF, RFC 1483 Multiprotocol Encapsulation Over ATM, Network Working Group, January, 1993.
- [28] The ATM Forum, *Traffic Management Specification Version 4.0*, af-tm-0056.000, 1996

## 1.6 ATM Network Service Assumptions

This LAN Emulation Over ATM specification is based on the ATM Forum User-Network Interface Specification, Version 3.0 [5] or later. The specification provides example Information Element encodings for UNI 3.0, 3.1 [17] and 4.0 [25].



## 2. Description of LAN Emulation Service

### 2.1 Architectural Overview

#### 2.1.1 Basic Concepts

LAN Emulation enables the implementation of emulated LANs over an ATM network. An emulated LAN provides communication of user data frames among all its users, similar to a physical LAN. One or more emulated LANs could run on the same ATM network. However, each of the emulated LANs is logically independent of the others. Communication between emulated LANs requires some type of interconnection device (bridge, router, etc.), even though direct ATM connections between emulated LANs are explicitly allowed in some circumstances. The creation and management of such inter-ELAN connections is outside the scope of this specification. However, the use of inter-ELAN connections must conform to this specification and must not negatively impact the operation of the emulated LANs.

This document specifies the operation of a single emulated LAN only. Each emulated LAN is one of two types: Ethernet/IEEE 802.3 or IEEE 802.5 (Token Ring). Each emulated LAN is composed of a set of LAN Emulation Clients (LE Clients, or LECs) and a single LAN Emulation Service (LE Service). This LE Service consists of one or more LE Configuration Servers (LECS), one or more LE Servers (LES), and one or more Broadcast and Unknown Servers (BUS). Each LE Client is part of an ATM end station. It represents a set of users, identified by their MAC Addresses. The LE Service may be distributed across multiple end stations and/or ATM switches as defined by [16].

Communication among LE Clients and between LE Clients and the LE Service is performed over ATM virtual channel connections (VCCs). Each LE Client must communicate with the LE Service over control and data VCCs. LANE v2 assumes the availability of point-to-point and point-to-multipoint Switched Virtual Circuits (SVCs). It is possible with sufficient configuration parameters to emulate SVC functionality using PVCs and thus operate LANE over PVCs. However, support for PVCs is beyond the scope of the LANE v2 specification.

An LE Client provides one MAC service interface to one ELAN. If an ATM end station needs multiple LANE MAC service interfaces (e.g., connections to multiple ELANs), it must use multiple LE Clients, one per LANE MAC service interface.

##### 2.1.1.1 LAN Destination Definition

LAN Emulation encompasses both Ethernet/IEEE 802.3 and IEEE 802.5 (Token Ring) emulation. In Ethernet/IEEE 802.3 emulation, a LAN Emulation component need examine only a data frame's destination MAC address in order to direct the frame towards its ultimate destination(s). In IEEE 802.5 emulation, however, a LAN emulation component may have to use a "Route Descriptor" extracted from the data frame's Routing Information Field (RIF), instead of the destination MAC address, in order to properly direct the frame over the Emulated LAN. Instead of the lengthy phrase, "Destination MAC address or, where required by IEEE 802.5 considerations, a Route Descriptor extracted from the RIF", this document uses the term, "LAN Destination."

Unless otherwise specified, a "LAN Destination" is either a unicast MAC address (one whose Individual/Group bit is clear) or a Route Descriptor. In cases where a multicast MAC address is permitted, the term, "unicast or multicast LAN Destination" is used. Note particularly that the unadorned term "LAN Destination" may always be applied to a Route Descriptor, even if the destination MAC address of the frame from which the Route Descriptor was extracted happens to be a multicast or broadcast MAC address.

##### 2.1.2 Architectural Perspective

The architecture of a communication system emphasizes the logical divisions of the system and how they fit together. This document incorporates the following types of architectural views:

- The (internal) layer interfaces that specify the interaction between the LE Client and the other entities within the end-station.
- The user-to-network interface that specifies the interaction between an LE Client and the LE Service over the ATM network.

- Network-to-network interfaces between components of the LE Service are beyond the scope of this document. They are defined in [16].

**2.1.2.1 Layer Interfaces**

In this architectural model, the layers interact by way of well-defined service interfaces, providing services as specified in Section 3. In general, the interface requirements are as follows (see Figure 1):

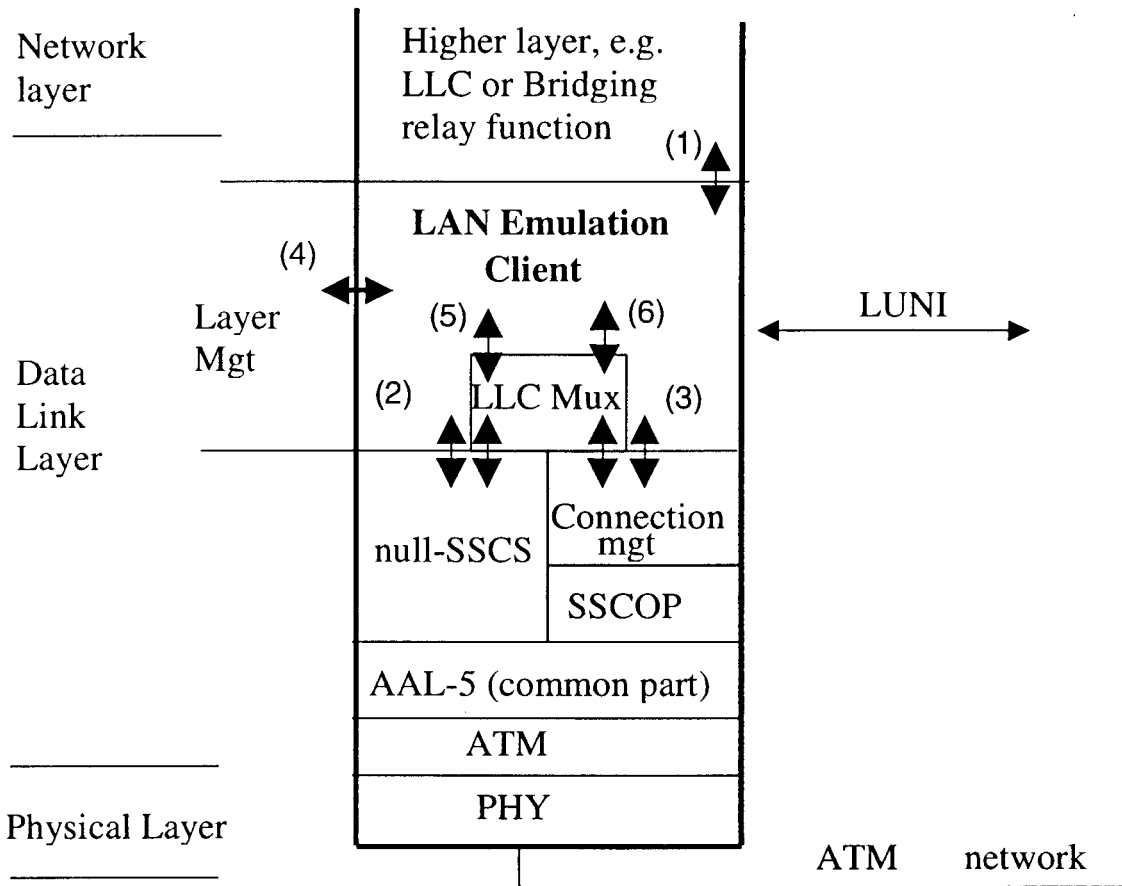

**Figure 1. The Layered Architecture of LAN Emulation**

- (1) The interface between the LAN Emulation layer and the Higher layers includes facilities for transmitting and receiving user data frames.
- (2) The interface to the ATM Adaptation Layer (AAL) includes facilities for transmitting and receiving AAL5 frames. AAL5 utilizes lower layers, including the ATM and PHY. Interface service access points are identified by SAP-IDs.
- (3) The interface to the Connection management entity includes facilities to request the setup or release of non-multiplexed VCCs.
- (4) The interface between the LE Client and the Layer Management entity includes facilities to initialize and control the LE Client and to return status information.
- (5) The Interface to the LLC Mux entity includes facilities for transmitting and receiving LLC-multiplexed frames. This interface is used for LLC multiplexed flows that can share VCCs with entities other than LANE V2. The definition of this interface is beyond the scope of this document

- (6) The Interface to the LLC Mux entity includes facilities to request the setup or release of LLC-multiplexed flows. This interface is used for LLC multiplexed flows that can share VCCs with entities other than LANE V2. The definition of this interface is beyond the scope of this document

### 2.1.2.2 LAN Emulation User Network Interface (LUNI)

In this architectural model, the LE Clients and the LE Service interact by way of a well defined interface, using PDUs and implementing protocols as specified later in this document. In general, the interface requirements are as follows (see Figure 2):

#### (1) Initialization:

- obtaining the ATM-Address(es) of the LE Services that are available on a particular ATM network
- obtaining configuration information from the LE Service
- joining or leaving a particular emulated LAN specified by the ATM Address of the LE Service.
- declaring whether this LE Client wants to receive address resolution requests for all the frames with unregistered destinations.
- declaring whether this LE Client will register to receive specific multicast MAC Addresses
- declaring whether this LE Client can accept and process LLC-multiplexed connections
- declaring whether this LE Client wants to receive Token Ring Explorer Frames

#### (2) Registration: Informing the LE Service of the following:

- the list of unicast MAC Addresses that the LE Client represents
- the list of Source Route descriptors (i.e., segment/bridge pairs) that the LE Client represents for Source Route bridging
- the list of multicast MAC Addresses that the LE Client will be receiving

#### (3) Address resolution:

- Obtaining the ATM Address representing the LE Client with a particular MAC Address (unicast or segment/bridge pair)
- Obtaining the ATM Address representing the LE Service serving a particular multicast MAC Address

#### (4) Data transfer: Moving the data from the source to the destination by:

- specifying and establishing connections between LE Clients, optionally with particular quality of service characteristics
- encapsulation of the LE-SDU (Service Data Unit) in an AAL5 frame and transmission by the LE Client
- forwarding the AAL5 frame by the LE Service (if applicable)
- receiving and decapsulating the AAL5 frame by the LE Client
- filtering one's own multicast/broadcast/unicast flood traffic

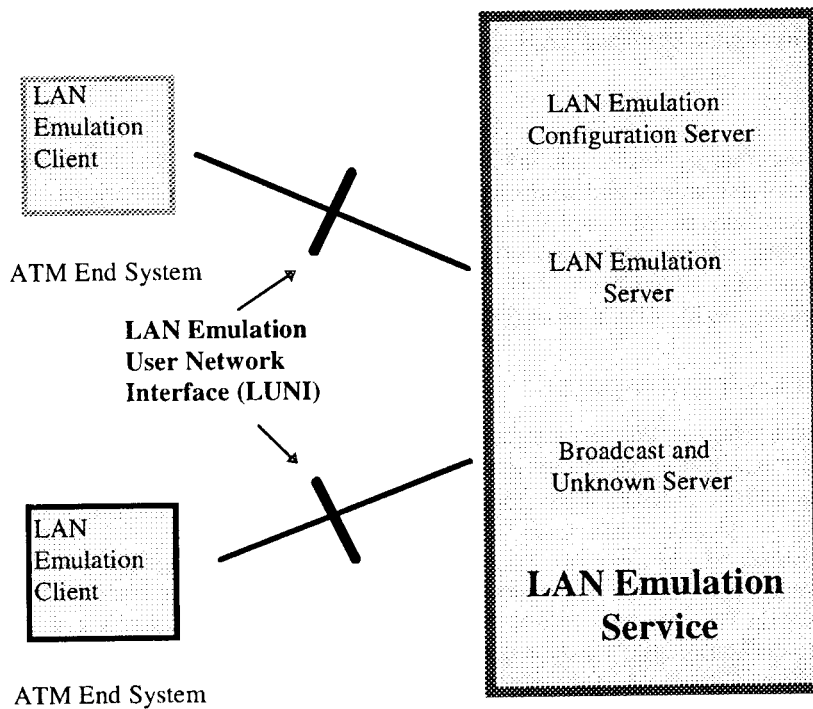

Figure 2. The LAN Emulation User Network Interface (LUNI)

### 2.1.3 Implementation Perspective

Users connect to the LAN Emulation service via LE Clients. LE Clients are typically implemented in ATM end stations, either as part of the software driver (between the Operating System and the ATM hardware) or on a special processor that is part of the ATM Adapter (the ATM specific hardware).

LAN Emulation is expected to be used in either of two configurations:

- (1) Intermediate Systems (e.g., bridges or routers). These devices enable the communication between any combination of "traditional" LANs and ATM end stations over ATM backbone networks.
- (2) End Stations (e.g., hosts or PCs). These devices enable the communication between ATM end stations and end stations on "traditional" LAN or among ATM end stations.

The LE Service might be implemented in any combination of ATM switches and ATM attached end stations (e.g., bridges, routers or workstations). An LE Service component may be co-located with an LE Client.

## 2.2 LAN Emulation Components

The components of an Emulated LAN network include ATM End Systems (e.g. ATM workstations and ATM bridges) each having at least one LE Client, and the components of the LE Service (one or more LE Servers, Broadcast and Unknown Servers, and LAN Emulation Configuration Servers).

### 2.2.1 LE Client (LEC)

The LE Client performs data forwarding and address resolution, provides a MAC level emulated Ethernet/IEEE 802.3 or IEEE 802.5 service interface to higher level software, and implements the LUNI interface in order to communicate with other components within a single Emulated LAN.

### 2.2.2 LE Server (LES)

The LE Servers implement the control coordination function for the Emulated LAN. The LE Servers provide a facility for registering and resolving unicast and multicast MAC addresses and/or route descriptors to ATM addresses. An LE Client is connected to only one LE Server. An LE Client may register LAN Destinations it represents and/or multicast MAC addresses it wishes to receive with its LE Server. An LE Client will also query its LE Server when the LE Client wishes to resolve a MAC address and/or route descriptor to an ATM address. The LE Server will either respond directly to the LE Client or forward the query to other clients so they may respond.

### 2.2.3 Broadcast and Unknown Server (BUS)

The Broadcast and Unknown Servers handle data sent by LE Clients to the broadcast MAC address ('FFFFFFFFFFFF'), multicast data, and initial unicast data which are sent by an LE Client before the data direct target ATM address has been resolved (before a data direct VCC has been established).

An LE Client sees a single Broadcast and Unknown Server. The multicast server function provided in the BUS is required as part of LAN Emulation to provide the connectionless data delivery characteristics of a shared network to LE Clients. The main tasks of the BUS are to distribute data with multicast MAC addresses (e.g. group, broadcast, and functional addresses); to deliver initial unicast data, where the MAC address hasn't yet been resolved to a direct ATM connection; and to distribute data with explorer Source Routing information. All broadcast, multicast and unknown traffic to and from an LE Client passes through this single entity.

An LE Client sends data frames to the BUS which serializes the frames and re-transmits them directly or indirectly to other LE Clients. Serialization is required to prevent the cells that make up the AAL5 frames from different sources from being interleaved.

The BUS participates in the LE Address Resolution Protocol (LE\_ARP) to enable an LE Client to locate its BUS. The BUS also handles ATM connections and manages its distribution group.

The BUS implementation may have multiple interfaces which support receiving and forwarding of specific multicast MAC addressed frames over multiple VCCs. If an LE Client does not need to receive all multicast MAC addressed frames, it may inform the LE Service during initialization. The LE Service may then selectively forward multicast MAC addressed frames to only those LE Clients which have requested them.

Some LE Clients take advantage of the multiple interfaces of the BUS and send frames destined for a specific multicast MAC address to a different BUS interface than that used for broadcast and unknown frames.

### 2.2.4 LE Configuration Server (LECS)

One or more LE Configuration Servers assign individual LE Clients to different Emulated LANs. Based upon its own policies, configuration database and information provided by LE Clients and other devices, an LECS assigns any client which requests configuration information to a particular emulated LAN service by giving that client the appropriate LES ATM address. This method supports the ability to assign a client to an emulated LAN based on either the physical location (ATM address) or the identity of a LAN Destination which it is representing.

All LE Clients must be able to obtain information from an LECS using the configuration protocol.

## 2.3 LAN Emulation Connections

Figure 3 shows an example of the set of connections across the LUNI interface in a simple configuration of two LE Clients, an LECS, an LES and a BUS. Other combinations may exist. See additional explanation below.

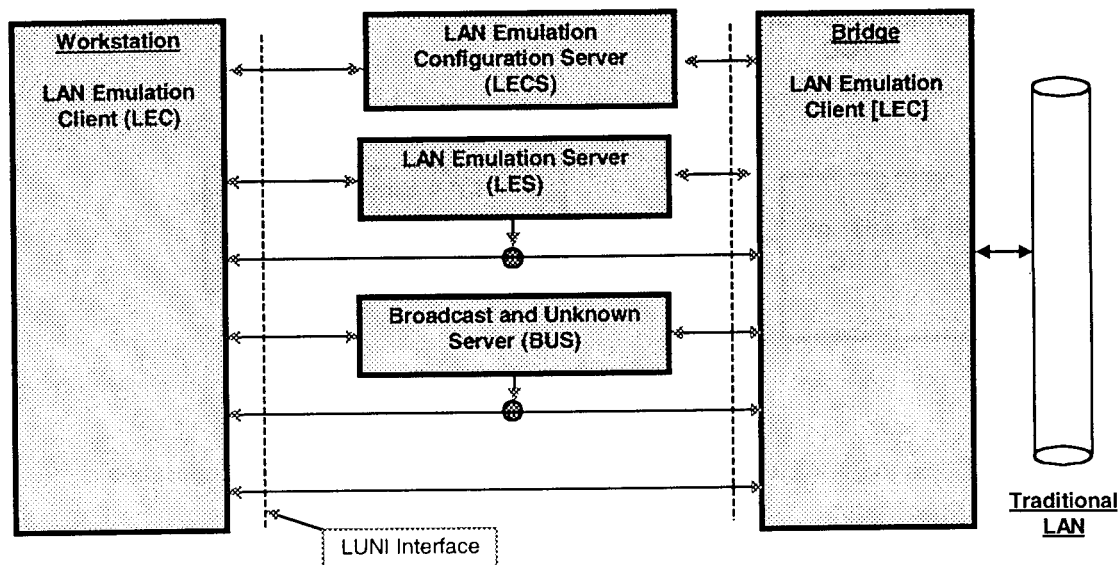

Figure 3. Example of LAN Emulation Client Flows across LUNI

### 2.3.1 VCCs and Flows Defined

LANE v1 supported only non-multiplexed VCCs. LANE v2 adds support for LLC-multiplexed VCCs. An LLC-multiplexed VCC carries traffic for one or more LANE flows and potentially traffic for other protocols. A LANE flow consists of data and/or selected control traffic for a single ELAN. A non-multiplexed VCC carries exactly one flow. Since LANE v1 supports only non-multiplexed VCCs, it uses the terms flow and VCC interchangeably.

Multicast Forward and Control Distribute flows are carried on point-to-multipoint VCCs. Data Direct, Control Direct, Configure Direct, Default Multicast Send and Selective Multicast Send flows are carried on point-to-point VCCs. The above flows are defined in Section 2.3.5.

Only Data Direct flows may be LLC-multiplexed. All other flows are non-multiplexed. In the context of a particular LE Client, this document uses the term Data Direct VCC to mean the VCC on which a particular Data Direct flow is carried. An LLC-multiplexed Data Direct VCC may be shared by multiple LE Clients as well as other protocols which support LLC-multiplexing as per [27].

### 2.3.2 Establishing Flows

LAN Emulation components need to establish flows. If an LLC-multiplexed VCC is already set up to the desired ATM address, a new flow may be established on that VCC. If there is no suitable VCC already set up or in the process of being set up, then a new VCC must be set up. This new VCC may be either LLC-multiplexed or non-multiplexed according to other protocol requirements.

### 2.3.3 Terminating Flows and VCCs

When a flow on a non-multiplexed VCC is terminated, the VCC is always released. When a flow is terminated on an LLC-multiplexed VCC, the VCC is not released until the number of flows using it is zero. Note that whereas with non-multiplexed VCCs a remote device can tell when a flow has been terminated by the corresponding VCC having been released, this is not necessarily the case with LLC-multiplexed VCCs. Therefore a device using LLC-multiplexed VCCs must be prepared to receive packets on a flow for some time after it has terminated that flow if the VCC still exists.

### 2.3.4 Control Flows and VCCs

One type of Control flow links an LE Client to an LECS. Other types of control flows link an LE Client to its LES. VCCs to carry the control flows are set up as part of the LE Client initialization phase and are shown in Figure 4 and 5.

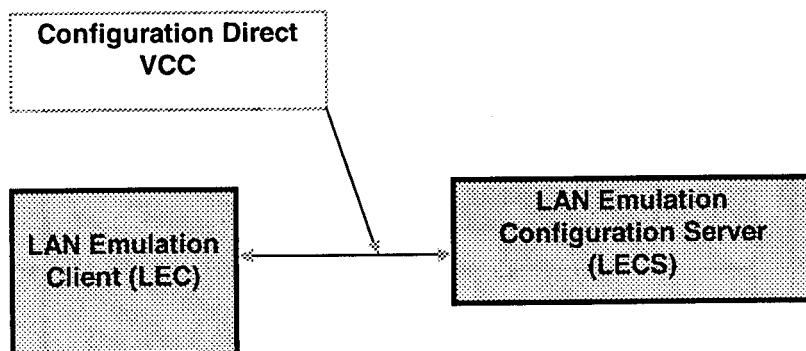

Figure 4. LE Client to LAN Emulation Configuration Server (LECS) Control Connection

2.3.4.1 Configuration Direct VCC

This bi-directional VCC is set up by the LE Client (or other entity) as part of the LECS Connect phase and is used to obtain configuration information, including the address of the LES. The entity may maintain this VCC while participating in the emulated LAN for further queries to its LE Configuration Server. The Configuration Direct VCC may be used to inquire about an LE Client other than the one to which the Configuration Direct VCC is attached. This VCC is signalled using B-LLI to indicate it carries "LE Control" frame formats (see Signalling Section 3.3.3).

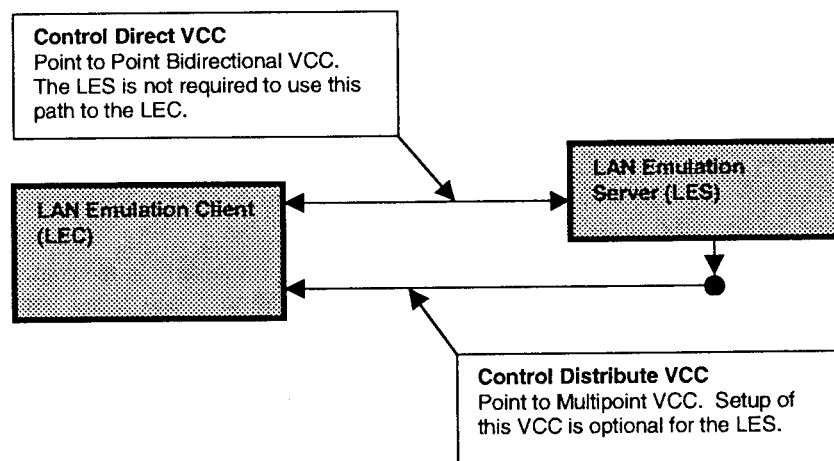

Figure 5. LAN Emulation Client to LAN Emulation Server (LES) Control Connections

2.3.4.2 Control Direct VCC

The LE Client establishes this bi-directional point-to-point flow to the LES for sending control traffic. It is established as part of the initialization phase. The LE Client is required to accept control traffic from this flow.

The LE Client and LES must not release the Control Direct VCC while participating in the Emulated LAN.

2.3.4.3 Control Distribute VCC

The LES may optionally establish a unidirectional point-to-multipoint Control Distribute VCC to the LE Client for distributing control traffic. The Control Distribute VCC may be set up by the LES as part of the initialization phase. If set up, the LE Client is required to accept the Control Distribute VCC.

The LE Client and LES must not release the Control Distribute VCC while participating in the Emulated LAN.

### 2.3.5 Data Flows and VCCs

Data flows connect the LE Clients to each other and to the Broadcast and Unknown Server. These flows carry Ethernet/IEEE 802.3 or IEEE 802.5 data frames as well as flush messages (see Section 10). Apart from flush messages data flows never carry control traffic.

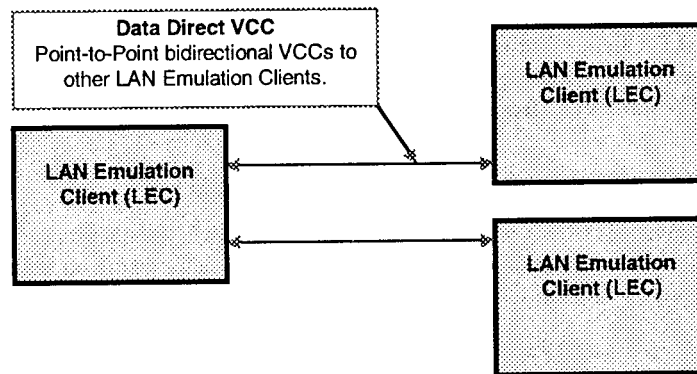

Figure 6. LAN Emulation Client to Client Data Connections

#### 2.3.5.1 Data Direct VCC

Data Direct VCCs are bi-directional point-to-point VCCs which are set up between LE Clients that want to exchange unicast data traffic. Figure 6 illustrates the Data Direct VCC. Connections from an LE Client to the BUS are shown in Figure 7.

When an LE Client has a frame to send and the ATM address for that destination is unknown, the LE Client generates an LE\_ARP request (see Section 7) to ascertain the ATM address for that destination.

Once the LE Client receives a reply to the LE\_ARP it establishes a Data Direct flow, if not already established, over which to send all subsequent data to that LAN Destination requested via the standard (connectionless) primitive for data transfer.

In addition to presenting a connectionless interface, an LE Client may provide a connection oriented interface to higher layers which allows applications to request that the LE Client attempts to set-up additional Data Direct VCCs to a destination with a specified Quality of Service.

An LE Client may establish additional Data Direct VCCs to a destination if it has traffic with particular Quality of Service requirements and the remote LE Client is able to accept such connections. The LE Client is not required to generate another LE\_ARP request if it already knows the destination's ATM address. It initiates the signalling to set up the additional Data Direct VCCs with the relevant signalling information elements to describe the desired Quality of Service. These connections must be bi-directional, since signalling a VCC with zero backward cell rate would prevent the destination from sending Flush requests (see section 9), and Ready queries (see Annex B), and furthermore, ABR connections require some return bandwidth for RM cells.

The LE Client that issues an LE\_ARP request and receives an LE\_ARP response is responsible for initiating the signalling to set up a Data Direct VCC with the responding client named in the LE\_ARP response.

Data Direct VCCs may be non-multiplexed or LLC-multiplexed.

#### 2.3.5.2 Multicast Send VCCs

An LE Client sets up one or more bi-directional point-to-point Multicast Send VCCs to the BUS. These VCCs are set up using the same process as for Data Direct VCCs. The LE Client sends an LE\_ARP for a broadcast/multicast address and, upon receiving the LE\_ARP response, initiates signalling to establish a Multicast Send VCC to the indicated ATM address (unless such a VCC is already established). These VCCs must be non-multiplexed.

The VCC associated with the broadcast MAC address (X"FFFFFFFFFFFF") is called the Default Multicast Send VCC, and is used for sending broadcast data to the BUS and for sending initial data to other unicast or multicast destinations. This is also the default path for all multicast data when the selective multicast procedures have not



provided an alternative path. The LE Client LE\_ARPs for other multicast MAC addresses and sets up additional VCCs, called Selective Multicast Send VCCs, as necessary. Multiple multicast MAC addresses may map to the same BUS ATM address. The BUS may use the return path on these VCCs to send data to the LE Client, so the LE Client must accept traffic from these VCCs.

The LE Client must maintain at least the Default Multicast Send VCC while participating in the Emulated LAN.

**2.3.5.3 Multicast Forward VCCs**

After the LE Client has set up the Default Multicast Send VCC, the BUS initiates the signalling for the (first) Multicast Forward VCC to the LE Client. The BUS may setup additional Multicast Forward VCCs at any time thereafter. These VCCs are used for distributing data from the BUS. They are unidirectional point-to-multipoint VCCs. At least one Multicast Forward VCC from the BUS must be established before an LE Client participates in the Emulated LAN.

The LE Client must maintain these VCCs while participating in the Emulated LAN.

The BUS may forward frames to an LE Client on either a Multicast Send VCC or a Multicast Forward VCC. An LE Client will not receive duplicate frames forwarded from the BUS, e.g., the same frame on both a Multicast Send VCC and a Multicast Forward VCC. The LE Client must accept all frames it receives on all Multicast VCCs.

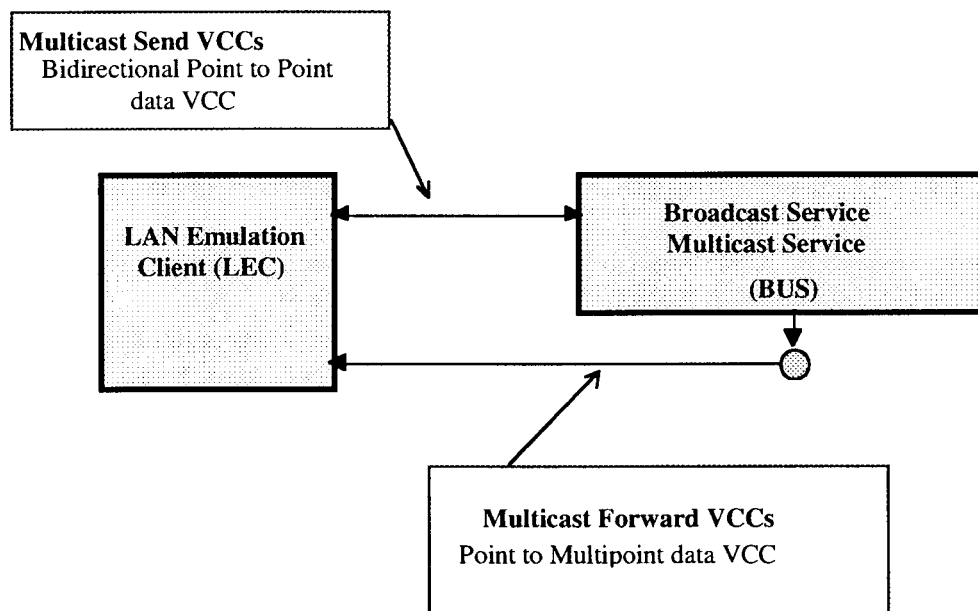

**Figure 7. LAN Emulation Client Broadcast/Multicast Connections**

## 2.4 Functions of the LAN Emulation Service

### 2.4.1 Initialization

This section discusses the Initial state, the Configuration function and the Join phase function. The Initial state refers to the parameters that are configured at the "beginning of time". The initialization is completed after the Join and Initial Registration processes have completed and the connections to the BUS have been established. At this point the LE Client becomes operational (See Figure 8. Initialization, Recovery and Terminating the ELAN.)

#### 2.4.1.1 Initial State

In the Initial State there are parameters (such as addresses, Emulated LAN name, max frame size, etc.)<sup>3</sup> that are known to the LE Server and LE Clients, respectively, about themselves, before participating in the Configuration and Join phase functions.

#### 2.4.1.2 LECS Connect Phase

In the LECS Connect Phase, the LE Client establishes a Configuration Direct VCC to the LE Configuration Server.

#### 2.4.1.3 Configuration Phase

This is the phase in which the LE Client discovers the LE Service in preparation for the Join phase. Every LE Client is able to support this phase, but individual LE Clients may be locally preconfigured with the necessary parameters instead.

#### 2.4.1.4 Join Phase

In the Join phase of ATM LAN emulation initialization, the LE Client establishes its control connections to the LE Server. The Join procedure may have two outcomes: success or failure.

Once the Join phase has successfully completed, the LE Client has been assigned a unique LE Client identifier (LECID), knows the emulated LAN's ELAN\_ID, maximum frame size, and LAN type (Ethernet/IEEE 802.3 or IEEE 802.5), and has established the Control VCC(s) with the LE Server.

#### 2.4.1.5 Initial Registration

After joining, an LE Client may register any number of unicast or multicast LAN Destinations and/or Route Descriptors. This is in addition to the single unicast LAN Destination that can be registered as part of the Join phase. Initial Registration allows an LE Client to verify the uniqueness of its local addresses before completing initialization and becoming operational.

#### 2.4.1.6 Connecting to the BUS

In order to establish a connection to the BUS, the LE Client LE\_ARPs for the all ones broadcast MAC address and proceeds to set up the Default Multicast Send VCC. The BUS then establishes one or more Multicast Forward VCCs to the LE Client.

---

<sup>3</sup>See Section 5.1 for the complete list.

### 2.4.1.7 Initialization Phases, Recovery and Termination

The figure below shows the steps in Initialization and the paths for termination and recovery from various phases. The conditions for termination and recovery are discussed in sections which follow.

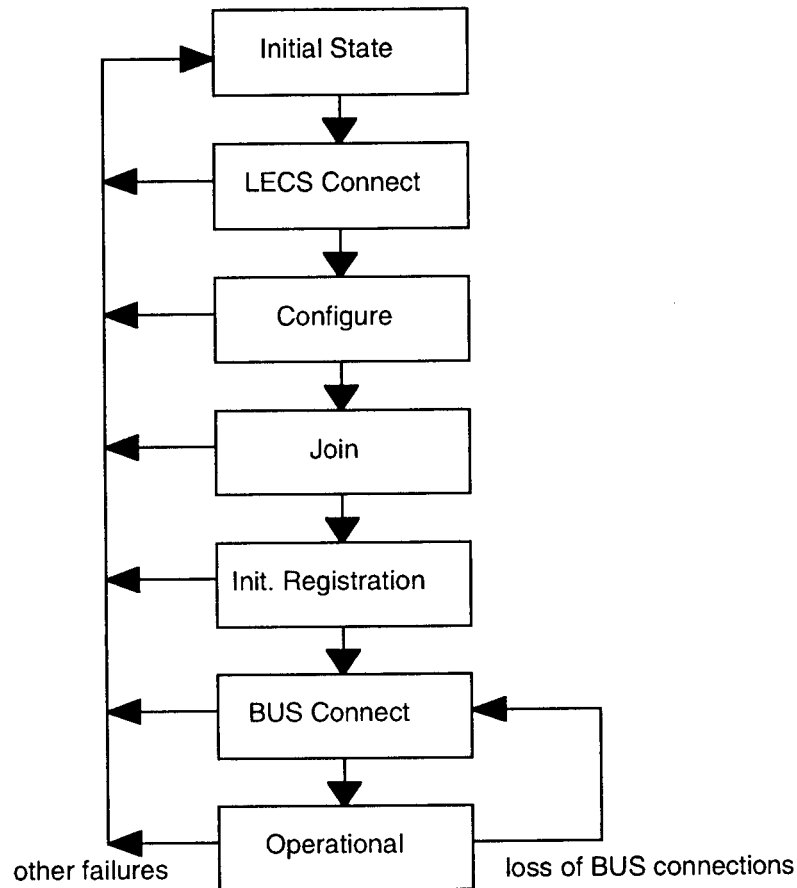

**Figure 8. Initialization, Recovery and Terminating the ELAN**

### 2.4.2 Registration

The address registration function is the mechanism by which LE Clients provide address information to the LE Server. An intelligent LE Server may respond to address resolution requests if LE Clients register their LAN Destinations (defined as unicast MAC addresses or, for source routing IEEE 802.5 LANs only, route descriptors) with the LE Server. An LE Client must either register all LAN Destinations for which it is responsible or join as a Proxy. In addition to registering for LAN Destinations, an LE Client wanting to take advantage of the selective multicast service will register for all multicast MAC addresses it wishes to receive. LAN Destinations and multicast addresses may be unregistered at any time as required by changes in the state of the LE Client.

### 2.4.3 Address Resolution

Address resolution is the procedure by which an LE Client associates a LAN Destination (unicast or multicast) with a particular ATM address of another LE Client or of the BUS. Address resolution allows LE Clients to establish Data Direct VCCs and Multicast Send VCCs.

When an LE Client is presented with a frame whose LAN Destination (multicast or unicast) is unknown to that client, it must issue a LAN emulation address resolution protocol (LE\_ARP) request frame to the LES over its Control Direct VCC.

The LES may either (1) forward this LE\_ARP frame to the appropriate LE Client(s) using the Control Distribute VCC or one or more Control Direct VCCs. Different LES implementations may use different distribution algorithms. If a client responds to a forwarded LE\_ARP request with an LE\_ARP reply, that reply is also sent and relayed over the control VCCs to the original requester.

Or alternatively (2), instead of forwarding the LE\_ARP, the LES may issue an LE\_ARP reply on behalf of a client that has registered the requested LAN Destination with the LES. The LES always responds to LE\_ARPs for multicast LAN Destinations.

An LE Client must respond to an LE\_ARP request that it receives asking for a LAN Destination it has registered with the LES, or for which it is a proxy.

Each LE Client maintains a cache of LE\_ARP replies, and uses a two-period time-out mechanism to age entries in this cache. The Aging Time period is used for all entries learned from LE\_ARP responses whose FLAGS field's Remote Address flag was zero. That is, responses for registered LAN Destinations are always timed out with the Aging Time. For aging entries learned from LE\_ARP replies with the Remote Address FLAGS bit set to 1 and for entries learned by observing source addresses on Data Direct VCCs, which time-out to use is determined by the state of the LE Client's Topology Change flag. When this flag is SET, such entries are aged using the Forward Delay Time. When this flag is CLEAR, such entries are aged using the Aging Time parameter. The state of this flag may be altered either by local management action or by reception of LE\_TOPOLOGY\_REQUEST messages (see Section 7.1).

The LE Client does not age out cached LE\_ARP replies for multicast LAN Destinations. Instead, these cached entries are removed when the corresponding VCCs go down.

#### 2.4.4 Connection Management

In switched virtual connection (SVC) environments the LAN Emulation entities (e.g. LE Client, LES and BUS) set up connections between each other using UNI signalling. Establishment of connections in other environments (e.g. Permanent Virtual Connections) is beyond the scope of this specification. The connections at a minimum use Best Effort Quality of Service. The method of connection set up is summarized in Annex B.

##### 2.4.4.1 Tear down & Time Out of VCCs

If a Control Direct VCC or Control Distribute VCC is ever released, an LE Client must always return to the LECS Connect phase of Initialization (See Section 5.2.). If the Default Multicast Send VCC is lost while the LE Client is participating in the ELAN, the LE Client may return to the BUS Connect Phase or go to the termination phase (See Section 11) and restart (depending on Cause Code, see Figure 8 and relevant text in Section 5.6.1.1.4).

#### 2.4.5 Quality of Service Considerations

An LE Client is permitted to establish multiple Data Direct VCCs to the same unicast LAN Destination, provided that the remote LE Client supports this. An LE Client indicates its willingness to receive multiple Data Direct VCC setup attempts to a particular unicast LAN Destination by registering a Service-Category TLV for that LAN Destination, thereby describing the service categories a remote LE Client might try to use to set up a connection. These additional connections will be established at the request of the higher layers to carry uni-directional flows of traffic with particular Quality of Service requirements.

This capability allows the higher layers to specify any of following signalling information elements when attempting to set up a connection, where some are only applicable to ATM Forum UNI Signalling Version 4.0 (SIG 4.0): ATM Traffic Descriptor, Alternative ATM Traffic Descriptor (only SIG 4.0), Minimum Acceptable ATM Traffic Descriptor (only SIG 4.0), Broadband Bearer Capability, Extended QoS Parameters (only SIG 4.0), QoS Parameter, End-to-End Transmit Delay (only SIG 4.0), ABR Setup Parameters (only SIG 4.0), and ABR Additional Parameters (only SIG 4.0). The particular values these information elements can take on will also be constrained by the version of signalling available to the LE Client. In addition, the Broadband Lower Layer Information element can be used to select either non-multiplexed or LLC-multiplexed for frames i.e. support for multiple Data Direct VCCs does not require support for LLC-multiplexing on those connections. Any elements not specified by the higher layers will be defaulted by the LE Client.

When no Quality of Service is specified by a higher layer, the Default Quality of Service MUST be used for the Data Direct VCC. The Default QoS is UBR or ABR, QoS Class 0 as defined in Section 3.3.3.

## 2.4.6 Data Transfer

The types of paths used for data frames in the emulated LAN are:

- Data Direct VCCs between individual LE Clients;
- Multicast Send and Multicast Forward VCCs that connect clients to the BUS.

### 2.4.6.1 Unicast Frames

When an LE Client has established via the address resolution mechanism that a certain LAN Destination corresponds to a certain ATM address, and when the client has a frame addressed to that LAN Destination to send, and when the client knows it has a Data Direct VCC to that ATM address with Quality of Service characteristics matching that of the frame, then the frame must be forwarded via that Data Direct VCC.

If an LE Client does not know which Data Direct VCC to use for given unicast LAN Destination, or if that Data Direct VCC has not yet been established, it may elect to transmit the frame over the Default Multicast Send VCC to the Broadcast and Unknown Server. This is permitted no matter what the desired Quality of Service characteristics of frame are, but frames sent via the Broadcast and Unknown Server will not have deterministic Quality of Service. The Broadcast and Unknown Server, in turn, forwards the frame to at least the client for which it is destined. If the LAN Destination is unregistered then the frame must be forwarded to at least all proxy clients and may be forwarded to all clients.

On an emulated LAN, the case can arise where a frame can only reach its destination through an IEEE 802.1D transparent bridge, and that bridge does not know the whereabouts of that destination. The only way such a frame can be assured of reaching its destination is for the frame to be transmitted to all of the IEEE 802.1D transparent bridges via the Broadcast and Unknown Server so that they, in turn, can flood that frame to all of their other bridge ports, or at least the ones enabled by the spanning tree protocol. An LE client that chooses not to forward frames to the Broadcast and Unknown Server, therefore, may not be able to reach destinations via transparent bridges (or perhaps other proxy agents.)

### 2.4.6.2 Multicast Frames

When an LE Client has established via the address resolution mechanism that a certain multicast MAC address corresponds to a certain ATM address, and the LE Client has established a Selective Multicast Send VCC to that ATM address, it sends all subsequent frames addressed to that multicast MAC address on that Selective Multicast Send VCC. In the absence of such a relationship to a Selective Multicast Send VCC, the LE Client sends a multicast frame on the Default Multicast Send VCC.

To send multicast frames to an LE Client, the BUS establishes one or more Multicast Forward VCCs. The minimum set of multicast frames which a LE Client will receive is dependent upon whether the LE Client supports Selective Multicast. If it does, then the LE Client must register for the specific multicast addresses it wishes to receive, and the BUS can avoid sending frames destined for other multicast addresses to that LE Client. Otherwise, the LE Client will receive all of the ELAN's multicast frames via its one or more Multicast Forward VCCs.

An LE Client which has accepted a Multicast Forward VCC must be prepared to receive on this connection and possibly discard frames sent to multicast MAC addresses that it has not registered.

Token Ring functional addresses are treated just as any other multicast MAC address.

### 2.4.6.3 Quality of Service for Data Direct VCCs

LANE v2 allows QoS Sets (or types) to be locally defined per LE Client. Each QoS Set defines a set of call setup parameters and an indication of whether the VCC may be shared with other flows (see Section 3.1.6).

Each Data Direct VCC is established using the parameters corresponding to one of the QoS Sets. A LANE v2 LE Client minimally has a single QoS Set corresponding to the default parameters for LANE UBR connections.

A LANE v2 LE Client always has at least a UBR QoS Set and, if supported, an ABR QoS Set, one of which will be used for frames requiring the default QoS and frames passed down with no QoS.

Received frames are not associated with a QoS Set.

## 2.4.7 Frame Ordering

### 2.4.7.1 Unicast Frame Ordering

There may be two paths for unicast frames between a sending LE Client and a receiving LE Client: one via the Broadcast and Unknown Server and one via a Data Direct VCC between them. For a given LAN Destination, a sending LE Client is expected to use only one path at a time, but the choice of paths may change over time. Switching between those paths introduces the possibility that frames may be delivered to the receiving LE Client out of order. Out-of-order delivery of frames between two LAN endpoints is uncharacteristic of LANs, and undesirable in an ATM emulated LAN. The flush protocol is provided to ensure the correct order of delivery of unicast data frames.

**NOTE:** One class of potential LE Clients includes IEEE 802.1D transparent bridges. These bridges are required by the IEEE 802.1D specification to deliver all frames in order. Even a sequence of frames such as:

1. MAC-A -> MAC-B
2. MAC-A -> multicast
3. MAC-A -> MAC-B

should be delivered in order to B. In actuality, many transparent bridges guarantee only that unicast frames will be delivered in order; the multicast frame in the example above will likely be delivered after frame 3. ATM LAN Emulation can guarantee only the ordering of unicast frames on a single VCC, and only where the transmitting LE Client implements the Flush protocol. The ordering of a mixed string of unicast and multicast frames on different VCCs under ATM LAN Emulation is explicitly not guaranteed.

Sending clients may choose to use the flush message protocol for unicast flows or not. In particular, if a sending client waits for some period of time for address resolution to work before utilizing the Broadcast and Unknown Server, then out-of-order frames can be minimized at the cost of some delay.

Any client receiving a flush request message must respond by sending a flush response message to the original sender.

### 2.4.7.2 Multicast Frame Ordering

The flush protocol cannot be used to ensure that a sequence of multicast frames arrives at the destination(s) in order. To minimize out of order delivery of multicast frames, the LE Client can delay when switching between paths.

## 2.4.8 Source Routing Considerations

Source route (SR) bridging is the predominant bridging technology used within IEEE 802.5 token ring networks. The use of source routing does not preclude transparent bridging in these networks. A token ring end station will typically use a combination of source routed and non source routed frames. The process described in this document allows an LE Client to operate with both source routing and transparent bridging.

In addition to the Destination Address (DA) field and Source Address (SA) field, a source routed frame contains a Routing Information (RI) field. The RI field contains a control field and a list of route descriptors (RD) that indicate the frame's path through the network. Therefore the information in the RI field determines which SR bridges will forward the frame. The LE Client determines if the frame is to be forwarded by a SR bridge or if the LAN Destination is a station on the ELAN.

The LE Client determines if the frame is to be forwarded by an SR bridge or if the LAN Destination is a station on the local emulated LAN by examining the RI field. If the LAN Destination is accessible through an SR bridge then the LAN Destination is the Next Route Descriptor (Next\_RD), otherwise, the LAN Destination is the frame's Destination Address.

Frames with specifically routed source routing information (an SRF frame) and unicast destination MAC addresses are sent on Data Direct VCCs following the usual LE\_ARP and VCC setup process. Other source routing frames are sent to the BUS.

## 3. LAN Emulation Service Specification

This section specifies the service interfaces between the LAN Emulation entity and the Higher layer, AAL, Connection Management and Layer Management entities. The services are described in an abstract way and do not imply any particular implementation, or any exposed interface.

### 3.1 LE to Higher Layer Services

These services apply only to the LE Client. The higher layer could be LLC (or equivalent) or a bridging relay function. The services provide the capability to exchange user data frames over the LAN Emulation service. Service definitions are compatible with ISO 10039 [7] service architecture and ISO 10038 [4] MAC Bridging standard.

#### 3.1.1 LE\_UNITDATA.request

This primitive requests the transfer of data from a local entity to a single peer entity, or multiple peer entities in case of multicast addresses.

The semantics of this primitive are as follows:

```

LE_UNITDATA.request (
    destination_address,
    source_address,
    routing_information {if applicable},
    frame type {if applicable},
    data,
    qos_handle {if applicable},
)

```

The `destination_address` parameter may specify either an unicast or a multicast MAC address. The `source_address` parameter is an unicast MAC address that specifies the source. The `routing_information` parameter applies only to Token Ring emulation. It will be transmitted by the LAN Emulation entity. The `data` parameter specifies the data unit to be transmitted by the LAN Emulation entity. It should include enough information to derive the length of the data parameter. The `frame type` is either IEEE 802.3 or Ethernet (if applicable). The `qos_handle` parameter selects a particular QoS Set to be used by the LE Client, if possible, to transmit the frame. If no `qos_handle` is specified, the LE Client uses the default QoS Set.

This primitive is generated by the Higher layer whenever it has data to be transferred to a peer entity or entities. A mapping of `MA_UNITDATA.request` for endstations and `M_UNITDATA.request` for bridges to `LE_UNITDATA.request` will be needed [4,7].

The receipt of this primitive will cause the LAN Emulation entity to effect transfer of the data to the appropriate peer LAN Emulation entity or entities.

#### 3.1.2 LE\_UNITDATA.indication

This primitive defines the transfer of data from the LAN Emulation entity to the higher layer.

The semantics of this primitive are as follows:

```

LE_UNITDATA.indication (
    destination_address,
    source_address,
    routing_information {if applicable},
    frame type {if applicable}
    data
)

```

The `destination_address` parameter may be either an individual or group address as specified by the incoming frame. The `source_address` parameter is an individual address as specified by the incoming frame. The `routing_information` (if applicable) and the data parameters specify the data unit as received by the LAN Emulation entity. The frame type is either IEEE 802.3 or Ethernet (if applicable).

The `LE_UNITDATA.indication` is passed from the LAN Emulation layer to the Higher layer to indicate the arrival of a frame. Such frames are reported only if they are validly formed and received without error.

The effect of receipt of this primitive is unspecified. A mapping of `LE_UNITDATA.indicate` to `MA_UNITDATA.indicate` for endstations and `M_UNITDATA.indicate` for bridges will be needed [4,7].

### 3.1.3 LE\_RESOLVE.request

This primitive requests the LAN Emulation entity to determine the ATM address and associated TLV information corresponding to a given LAN Destination address, as if sending data to that address, but without sending any data.

The semantics of the primitive are as follows:

```
LE_RESOLVE.request (
    destination_address,
    routing_information {if applicable},
    force_LE_ARP,
    source_LAN_Destination,
    TLV_list
)
```

The `destination_address` parameter may specify either an individual or a group MAC address. The `routing_information` parameter applies, and will be transmitted by the LAN Emulation entity, only in Token Ring emulation. The `source_LAN_Destination` parameter specifies a Source MAC Address, the `TLV_list` parameter specifies the list of TLVs associated with the `source_LAN_Destination`. These parameters will be used only if an `LE_ARP` is issued. The response to this request, if any, will be in the form of a `LE_ASSOCIATE.indication`.

If `force_LE_ARP` is set, then the LE Client must issue an `LE_ARP` for the destination. This permits the higher layers to force the learning of any TLVs associated with a LAN Destination.

### 3.1.4 LE\_ASSOCIATE.request

This primitive requests the LAN Emulation entity to make a given association in its local variables. The `LE_ASSOCIATE` primitive allows users of the LE Service to define TLVs and associate them with specific LAN Destinations. Once this association is made, these user defined TLVs are carried in `LE_ARP` request/response frames and `LE_REGISTER` frames.

The semantics of the primitive are as follows:

```
LE_ASSOCIATE.request (
    LAN_Destination,
    TLV_list
)
```

The `LAN_Destination` parameter may specify either a unicast MAC address or route descriptor. `TLV_list` contains the list of TLVs to be associated with the given LAN Destination. The `TLV_list` replaces entirely any previous association that may have been created for the `LAN_Destination`. Associating a null `TLV_list` thus is equivalent to removing a previous association.

Because the association of TLV information with a particular LAN Destination may have significance outside of the scope of LANE and this specification, the LE Client must ensure that – in the event that this information has changed – other LANE entities that may now have an incorrect association are notified that the previous information is out of



date. The determination of "change" is a local matter. The mechanism(s) used to do this may include LE\_REGISTER, LE\_NARP and the Terminate procedure.

### 3.1.5 LE\_ASSOCIATE.indication

This primitive returns the association for a given LAN Destination.

The semantics of the primitive are as follows:

```
LE_ASSOCIATE.indication (
    LAN_Destination,
    TLV_list
)
```

The LAN\_Destination parameter may specify either an individual or a group MAC address. TLV\_list contains the list of TLVs found in association with the given LAN\_Destination (e.g. - via LE\_ARP).

Because the association of TLV information with a particular LAN Destination determined from LE\_ARP may have significance beyond LANE and this specification, the LEC must assume that the higher layers are "interested" in any LE\_ARP response received by the LE Client that contains TLV information not understood by the LE Client itself. In addition, the LE Client may be required to retain minimal state on LE\_ARP responses received with such TLVs (e.g., TLV type, checksum, CRC, etc.) in order to be able to determine when such notification is required for subsequent LE\_ARP\_RESPONSEs that do not contain this TLV. Alternatively, the LE Client may elect to forward a portion of all LE\_ARP\_RESPONSEs – including at least all TLVs which it does not understand – to the higher layers.

### 3.1.6 Quality of Service Interface to Higher Layer Services

The services specified in this section permit the higher layers to access some of the connection-oriented Quality of Service characteristics of the underlying ATM network. This interface is an optional extension for a LANE v2 LE Client.

The QoS capabilities of LAN Emulation are defined in terms of "QoS Sets" and "QoS Bindings". A QoS Set is a collection signalling information elements, identified by a "qos\_handle". A QoS Binding is a linking of a QoS Set to a specific VCC.

A QoS Set is created in an LE Client, its QoS-related signalling information elements are defined, and a qos\_handle is assigned, by means of a LANE primitive called by the higher layers. The qos\_handle is selected by the LE Client to uniquely identify each QoS Set within that LE Client but does not appear in any LANE protocol message. Qos\_handles may therefore be duplicated by different LE Clients in the same box.

A QoS Set should not contain signalling information which are not QoS-related, e.g. the called party ATM address. It must contain all of the mandatory QoS information elements. A QoS Set is also characterized as being either a "Sharable QoS Set" or a "Non-Sharable QoS Set". Any number of QoS Sets may have exactly the same set of signalling information elements, but with different qos\_handles.

Every LE Client has a Default QoS Set which is used when no qos\_handle is specified in the LE\_UNIDATA.request. This Default QoS Set is a Sharable QoS Set which contains the information elements defined in section "3.3.3.7 SETUP Message Contents".

A QoS Binding is created automatically in an LE Client when the LE Client binds a QoS Set to a VCC. The QoS Binding is created as a side effect of processing an LE\_UNIDATA.request which specifies a qos\_handle, and lasts until either the VCC is released or the specified QoS Set is destroyed by the higher layers.

A single QoS Set may be bound to any number of VCCs, and thus participate in any number of QoS Bindings, as long as no two of those VCCs connect the same pair of ATM addresses. In other words, among the set of VCCs connecting an LE Client's ATM address to a particular other LE component, at most one of those VCCs may be bound to any one QoS Set.

A given VCC may be bound to no QoS Sets at all. A Non-Sharable QoS Set may not be bound to any VCC that is also bound to any other QoS Set, whether sharable or not. Any number of Sharable QoS Sets may be bound to a single VCC. The VCC in a given QoS Binding may or may not have completed the signalling procedures, and thus

may or may not be ready to transmit or receive data. In a multiple-LEC implementation which supports LLC multiplexing, Sharable QoS Sets for different LECs may be bound to the same VCC.

In order to use the LANE QoS services, the upper layers must first create one or more QoS Sets. As data frames are issued to the LE Client via LE\_UNITDATA.requests, QoS Bindings are created. No VCC can be used as a Data Direct or Selective Multicast Send VCC for transmitting data frames until it is bound to some QoS Set. Data can be received on a VCC whether or not it is bound to a QoS Set.

When a data frame is passed down to the LE Client with a qos\_handle, the LE Client attempts to use or create a QoS Binding according to the following rules. These rules supplement those described in chapters 7 and 8, which ignore the optional QoS service. The selection of a VCC for transmitting a data frame are conditioned in chapters 7 and 8 upon finding a VCC which is connected to the correct other LE component. The selection rules here allow multiple VCCs to the same other LE component, and select among them according to QoS Bindings.

1. The LE Client determines, through the means specified in chapter 7, the ATM Address of the LE Component to which the data frame should be sent.
2. If the destination ATM address can be immediately determined, the LE Client looks to see if there is a QoS binding for the selected (or default) QoS Set and a VCC which is connected to the desired ATM address. If so, that VCC is selected for transmitting the data frame. The rules for creating QoS Bindings ensure that no more than one suitable VCC can be found.
3. If there is no suitable QoS Binding, and if there exists a VCC which is 1) connected to the correct ATM address; 2) is allowed by the binding rules above to be bound to the selected (or default) QoS Set; and 3) whose signalling information elements "nearly exactly" match those specified in the QoS Set; then that VCC is selected for transmitting the data frame. A QoS Binding linking that VCC and the QoS Set is created. The definition of "nearly exactly" is necessarily imprecise, and is left to the implementer's judgment and experience.
4. If there is more than one such matching VCC, then exactly one VCC must be selected for binding to the QoS Set. The one VCC selected is the one whose calling party ATM address is numerically lower than the called party ATM address. If there is more than one such VCC, then the VCC which was the earliest created (that is, the VCC whose SETUP or CONNECT message was received first) is selected for transmission and bound to the QoS Set.
5. If no suitable VCC exists or is in the process of being signalled, then the LE Client must initiate signalling procedures to create a suitable VCC. The QoS-related signalling information elements for the SETUP are obtained from the QoS Set. The VCC being created is selected and bound to the QoS Set.
6. If the VCC cannot successfully be established, then the following procedure is suggested:
  - The Service-Category TLV returned in LE-ARP exchanges indicate which Service Categories may be used to generate QoS-related SETUP information elements to establish the VCC. If successful, the newly-created VCC is bound to the originally-specified QoS Set. In this case, ABR service should be signalled only after all other Service Categories have been exhausted. Note that this QoS Binding is created even though the call setup information elements in the QoS Set may not match the VCC's information elements.
  - If using the Service Class TLV fails to create a VCC, then a VCC should be signalled using the QoS-related signalling information elements from the default QoS Set, and the VCC bound to the originally-specified QoS Set. Again, this binding is made in spite of any differences in signalling information elements between the bound QoS Set and the default QoS set.
7. If the ATM address of the destination LAN component cannot be determined immediately, or if the VCC finally selected is not yet ready to transmit data, then the data frame must be held, discarded, or sent to the BUS as defined in chapters 7 and 8.
8. Whenever new VCCs are initiated by other LE components and accepted by an LE Client, that LE Client should examine all of its QoS Bindings. If, by the collision rules specified above, there exists a QoS Binding that should be transferred from its current VCC to the new VCC, then that transfer should be made.

In terms of externally-observable LE Client behavior, there is no difference between an LE Client which implements the QoS services but whose higher layers create no QoS Sets and pass no qos\_handles in the LE\_UNITDATA.requests, and an LE Client which does not implement the QoS service at all. That is, in the default-only QoS case, the QoS service behavior is indistinguishable from the non-QoS behavior.

If two LE Clients each initiate signalling of a VCC to each other at more-or-less the same time, then it is possible that the VCC selection rules above result in one of the LE Clients selecting one VCC, and the other LE Client selecting the other VCC. In this case, the two LE Clients may wind up each using one-half of each of two VCCs, and thus may waste provisioned bandwidth. In practice, such undetected collisions should be a rare event.

In terms of externally-observable LE Client behavior, if two LE Clients have different definitions of "nearly exactly match", the differences should be very small.

In fact, in terms of externally-observable LE Client behavior, it is probable that any two reasonable but different implementations of QoS services will interoperate. For this reason, this section is to be considered a reference, and not to specify mandatory behavior. For this reference to be useful, any alternative QoS service implementation should be designed so that it will provide satisfactory interoperability with an implementation of the design presented here.

When a QoS Set is undefined by the higher layers, all QoS Bindings incorporating that QoS Set are deleted by the LE Client.

Whenever a bound VCC is released, whether by the other party, or by the LE Client, e.g. because its idle timer expires, any QoS Bindings attached to that VCC are deleted. The QoS Sets themselves are not destroyed; only their bindings to the released VCC.

### 3.1.6.1 LE\_QOS\_DEFINE.request

This primitive is used by the higher layer to create a QoS Set, make it available to the LE Client for binding to VCCs, and to assign it a qos\_handle.

The semantics of this primitive are as follows:

```
LE_QOS_DEFINE.request(
    setup_parameters,
    shareable_flag,
    qos_handle
)
```

The setup\_parameters and shareable\_flag define the QoS Set. The LE Client returns in qos\_handle a label for the QoS Set which is unique across all the QoS Sets defined in that LE Client.

### 3.1.6.2 LE\_QOS\_UNDEFINE.request

This primitive is used by the higher layer to indicate that it is no longer using one of its dynamically defined Classes of Service.

The semantics of this request are as follows:

```
LE_QOS_UNDEFINE.request(
    qos_handle
)
```

qos\_handle identifies the QoS Sets that the higher layer no longer requires.

### 3.1.6.3 LE\_QOS\_ERROR.indication

This primitive indicates to the higher layer that the indicated qos\_handle is not valid.

```
LE_QOS_ERROR.indication(
    qos_handle
)
```

The qos\_handle identifies the referenced QoS characteristics. The LEC uses this primitive if the higher layer attempts to send data with an invalid qos\_handle.

## 3.2 LAN Emulation to AAL Services

These services apply to the LE Clients and the LE Service. These services provide the capabilities to transfer frames between peer LAN Emulation layers. This specification assumes a null SSCS layer, i.e., the SSCS provides for the mapping of the equivalent primitives of the AAL and CPCS. The common part of AAL5 makes use of the services provided by the underlying ATM layer.

A LAN Emulation entity includes the following AAL service interfaces, each identified by a distinct SAP-ID. Each LE Client includes the following SAPs:

- (1) One or two control SAPs that handle initialization, registration and address resolution.
- (2) Two or more data forwarding SAPs.
- (3) Zero or one control SAPs that handle configuration.

### 3.2.1 AAL\_UNITDATA.request

This primitive provides the capability to transfer the AAL\_SDU from one LAN Emulation layer to a peer LAN Emulation layer, or multiple LAN Emulation layers.

The semantics of this primitive are as follows:

```
AAL_UNITDATA.request(
    SAP_ID
    payload
)
```

The SAP-ID specifies the point-to-point or point-to-multipoint VCC. The payload parameter specifies the data unit to be transmitted by AAL5.

This primitive is generated by the LAN Emulation entity whenever it has data to be transferred to a peer entity or entities.

The receipt of this primitive will cause the AAL5 entity to transmit the payload on the specified connection.

### 3.2.2 AAL\_UNITDATA.indication

This primitive provides the capability to transfer data from the AAL5 entity to the LAN Emulation layer.

The semantics of this primitive are as follows:

```
AAL_UNITDATA.indication(
    SAP_ID
    payload
)
```

The SAP\_ID identifies the VCC on which data was received. The payload parameter specifies the data unit as received and reassembled by the AAL5 entity.

The AAL\_UNITDATA.indication is passed from the AAL5 layer to the LAN Emulation layer to indicate the arrival of a frame. Such frames are reported only if they are completely reassembled and received without error.

The received payload is processed by the LAN Emulation entity or passed to the higher layer.

## 3.3 Connection Management Services

These services apply to the LE Clients and the LE Service.

The conceptual model assumed by the LAN Emulation layer was illustrated in Figure 1: the Connection Management provides the primitives described below in sections 3.3.3.1 through 3.3.3.4 (this is labeled as interface

(3) in Figure 1). In particular, the Connection Management module provides a mapping from { near-end ATM address, far-end ATM address, B\_LLI } to VPI/VCI.

### 3.3.1 Non-Multiplexed Connections

Non-multiplexed connections use a unique B-LLI codepoint to indicate the format of the frames that are used. When establishing non-multiplexed point-to-point connections, the non-multiplexed version of the READY\_IND protocol is used.

### 3.3.2 LLC-Multiplexed Connections

In general, this specification refers to individual connections (VCCs). When using LLC-multiplexed Data Direct VCCs, these timers, etc, refer to the flow, not the connection. It is assumed that LLC-multiplexed VCCs will perform their own connection management, including idle timeouts, etc. All LANE Data Direct “connections” can exist as flows over existing LLC-multiplexed VCCs. The LLC layer is shown in Figure 1. Connection Management performs services directly for LANE as well as the LLC Mux.

### 3.3.3 Switched Virtual Circuits (SVCs)

Connection management of SVCs uses the UNI Signalling protocols described in [5], [17] and [25]. Connection management provides at least the following services for SVCs.

#### 3.3.3.1 SETUP

This service provides initial call establishment. It receives an ATM Address and establishes a virtual connection, identified by a SAP-ID. It includes the following UNI calls:

CALL_SETUP invoke	(Causes a SETUP message to be sent)
CALL_SETUP signal	(Indicates a SETUP message has been received)
CALL_CONNECT invoke	(Causes a CONNECT message to be sent)
CALL_CONNECT signal	(Indicates a CONNECT message has been received)
CALL_CONNECT_ACKNOWLEDGE invoke	(Causes a CONNECT_ACKNOWLEDGE message to be sent)
CALL_CONNECT_ACKNOWLEDGE signal	(Indicates a CONNECT ACKNOWLEDGE message has been received)

#### 3.3.3.2 RELEASE

This service is used to request the network to clear an end-to-end connection (if any), identified by a SAP-ID. It includes the following UNI calls:

CALL_RELEASE invoke	(Causes a RELEASE message to be sent)
CALL_RELEASE signal	(Indicates a RELEASE message has been received)
CALL_RELEASE_COMPLETE invoke	(Causes a RELEASE COMPLETE message to be sent)
CALL_RELEASE_COMPLETE signal	(Indicates a RELEASE COMPLETE message has been received)

#### 3.3.3.3 ADD PARTY

This service provides the capability to add a party to an existing point-to-multipoint connection. It includes the following UNI calls:

CALL_ADD_PARTY invoke	(Causes an ADD PARTY message to be sent)
CALL_ADD_PARTY signal	(Indicates an ADD PARTY message has been received)
CALL_ADD_PARTY_ACKNOWLEDGE invoke	(Causes an ADD PARTY ACKNOWLEDGE message to be sent)
CALL_ADD_PARTY_ACKNOWLEDGE signal	(Indicates an ADD PARTY ACKNOWLEDGE message has been received)
CALL_ADD_PARTY_REJECT invoke	(Causes an ADD PARTY REJECT message to be sent)
CALL_ADD_PARTY_REJECT signal	(Indicates an ADD PARTY REJECT message has been received)

### 3.3.3.4 DROP PARTY

This service is used to drop (clear) a party from an existing point-to-multipoint connection. It includes the following UNI calls:

CALL_DROP_PARTY invoke	(Causes a DROP PARTY message to be sent)
CALL_DROP_PARTY signal	(Indicates a DROP PARTY message has been received)

### 3.3.3.5 Addressable Components

LAN Emulation is composed of six types of connections, distinguished by B-LLI code values. The first type carries all LAN Emulation LLC-multiplexed data traffic, and can be used by other (non-LAN Emulation) protocols, as well. The second carries LAN Emulation control protocol, and the other four types carry LAN Emulation non-multiplexed compatible Ethernet/IEEE 802.3 and IEEE 802.5 formatted frames. When an end system receives a SETUP message indicating an incoming call, it needs to have sufficient information within the message in order to "bind" the call to the appropriate application and instance. Sufficient information is required to distinguish between the different types of LAN Emulation non-multiplexed VCCs such as Ethernet/IEEE 802.3, IEEE 802.5 and Control VCCs and between other applications using ATM such as LAN Emulation LLC-multiplexed and RFC 1577 LLC-multiplexed connections.

LAN Emulation uses a combination of B-LLI values, ATM addresses, and LLC code points to distinguish between VCCs of different types and between different LAN Emulation entities. An LE Client and other LAN Emulation components need to examine the calling and called party numbers and the B-LLI values to identify the type of VCC, and in the case of the LLC-multiplexed B-LLI value, the LLC information at the head of every received frame, to identify the LAN emulation components, and to distinguish between LAN Emulation non-multiplexed connections and other ATM applications. ATM addresses that differ only in the selector (SEL) octet are recognized as different ATM addresses in the context of LAN Emulation.

Details are covered in the following sections.

### 3.3.3.6 Connection Establishment Overview

The call and connection procedures in the UNI (Sections 5.5 and 5.6 of UNI 3.0, 3.1 and SIG 4.0) apply. The following sections describe the requirements imposed by LANE on the establishment of LANE VCCs. These are in addition to any requirements of the signalling protocol. In addition, default parameter encodings for UBR and ABR service category LANE connections are specified.

### 3.3.3.7 General Connection Establishment Requirements

#### 3.3.3.7.1 Acceptance of Incoming Connections

A LANE component SHOULD accept any connection which meets the requirements of Section 3.3.3.8 and elsewhere in this document if it can support the service requested and has sufficient resources. A LANE component MUST NOT reject a connection just because there are additional user-to-user information elements in the SETUP or ADD PARTY message beyond those required by LANE (e.g. Broadband High Layer Information, Generic Identifier Transport).

#### 3.3.3.7.2 Rejection of Connections

A LANE component **MUST** reject connections which do not satisfy the requirements specified in Section 3.3.3.8 unless otherwise specified.

The LLC connection management entity co-resident with an LE Client might accept an LLC-multiplexed VCC which does not satisfy LANE connection requirements. A LANE component **MUST** not use such a VCC. This does not stop other protocols from using the VCC.

### 3.3.3.7.3 LANE Requirements of ATM Network

For LANE to operate correctly over an ATM network, the network needs to support at least the information elements used to set up LANE UBR connections. Specifically, the ATM network must support the transport of the ATM Adaptation Layer Parameters, Broadband Low Layer Information and Calling Party Number information elements.

#### 3.3.3.7.4 UNI 3.0 Information Element Encoding Requirements

The spare bit defined in octet 2 of each information element in UNI 3.0 is now used in UNI 3.1 and SIG 4.0 as the UNI 3.0 "Action Indicator" field has been extended to 3 bits and renamed the "IE Action Indicator". A UNI 3.0 implementation **SHOULD** ensure that the spare bit of the Action Indicator is set to 0. Information elements with the IE Action Indicator field equal to binary 100 are reserved in UNI 3.1 and SIG 4.0 and **MUST** be rejected.

### 3.3.3.8 SETUP and ADD PARTY Message Contents

#### 3.3.3.8.1 ATM Adaption Layer (AAL) Parameters

This information element<sup>4</sup> **MUST** be used in the SETUP or ADD PARTY message.

Table 2. AAL Parameters

Field	Value
AAL Type	5 (for AAL5)
Forward Maximum CPCS-SDU Size	Control: 1516 octets for LE Configuration Direct VCCs, LE Control Direct and LE Control Distribute VCCs. Data: one of the standard AAL5 SDU Max. octet values from Table 37. LLC-multiplexed VCCs <b>MAY</b> be signalled with maximum AAL5 SDU sizes larger than those given in Table 37 if the VCC is likely to be shared with another protocol requiring a larger maximum AAL5 SDU size.
Backward Maximum CPCS-SDU Size	For point to point connections: Same as Forward Maximum CPCS-SDU Size For point-to-multipoint connections: 0
Mode <sup>5</sup>	1 (Message mode)
SSCS Type	0 (Null SSCS)

#### 3.3.3.8.2 ATM User Cell Rate /ATM Traffic Descriptor

The term "ATM User Cell Rate" is used in UNI 3.0, whereas the term "ATM Traffic Descriptor" is used in UNI 3.1 and later.

This information element<sup>6</sup> **MUST** be present in the SETUP message. Only the parameters needed are included. The calling user may specify any valid combination of parameters in this information element subject to the requirements

<sup>4</sup>Reference: Section 5.4.5.5 of [5, 17, 25]

<sup>5</sup>This field encoding **MUST** be present in the outgoing SETUP or ADD PARTY for UNI 3.0 and **MUST NOT** be present in UNI 3.1 or SIG 4.0. A UNI 3.0 implementation **MUST NOT** reject a connection just because this parameter is not present in the AAL Parameters IE.

<sup>6</sup>Reference: Section 5.4.5.6 of [5, 17, 25]

on backwards cell rates and frame discard specified below. Default values for UBR and ABR connections are specified in Table 3.

If the called party rejects a UBR call with cause #51 or #37, the calling user SHOULD retry the call with a lower value of PCR.

The backwards cell rate fields for LANE point-to-point VCCs MUST be non-zero to support the READY protocol. For backwards compatibility, a called user MUST NOT reject an incoming SETUP message just because it does not satisfy this requirement.

For SIG 4.0, a calling user MUST request frame discard service in both directions from the network by including the frame discard indicators in the ATM Traffic Descriptor information element in the SETUP message and following signalling procedures as described in Section 2.2.1 of UNI 4.0 Signalling. For backwards compatibility, a called user MUST NOT reject an incoming SETUP message just because it does not satisfy this requirement.

**Table 3. ATM User Cell Rate/ATM Traffic Descriptor for UBR/ABR**

Field	Value
Forward Peak Cell Rate (CLP=0+1)	line rate in cells per second (UBR) or as desired (ABR)
Backward Peak Cell Rate (CLP=0+1)	line rate in cells per second (UBR) or as desired (ABR) 0 for point-to-multipoint connections
Best Effort Indicator	0xBE (UBR only)
Traffic Management Options Identifier	0xBF (SIG 4.0 only)
Forward Frame Discard Indicator	1 (frame discard allowed in forward direction)
Backward Frame Discard Indicator	1 (frame discard allowed in backward direction)
Forward ABR Minimum Cell Rate	As desired (ABR only)
Backward ABR Minimum Cell Rate	As desired (ABR only)

### 3.3.3.8.3 Minimum Acceptable ATM Traffic Descriptor (SIG 4.0 Only)

A calling user MAY request traffic parameter negotiation in the SETUP message. When traffic parameter negotiation is requested the calling user MUST include the Minimum Acceptable ATM Traffic Descriptor information element in the SETUP message, additional signalling procedures as described in Section 8 of SIG 4.0 MUST be followed.

For UBR connections, the Minimum Acceptable ATM Traffic Descriptor SHOULD be included in the SETUP message. In this case, the network negotiates the Forwards and/or Backwards Peak Cell Rate parameters downwards to reflect the smallest bandwidth limitation along the path of the connection.

### 3.3.3.8.4 ABR Setup Parameters (SIG 4.0 Only)

This information element MUST be included in the SETUP message when requesting the ABR service category. The calling user MUST follow signalling procedures outlined in Section 10.2.1 in SIG 4.0.

### 3.3.3.8.5 Broadband Bearer Capability

This information element<sup>7</sup> MUST be used in the SETUP message sent by the calling party. It is used to indicate what kind of network connection is desired. The calling user may specify any valid combination of parameters in this information element. Default values for UBR and ABR are specified in Table 4.

For the Bearer Class, this specification recommends using Bearer Class X. However as an alternative, Bearer Class C could be used instead. When the calling party receives an indication from the network that Bearer Class X is not

<sup>7</sup>Reference: Section 5.4.5.7 of [5, 17, 25]



supported via a RELEASE or RELEASE COMPLETE message with Cause 57 (Bearer Capability not Authorized) or Cause 58 (Bearer Capability Not Presently Available), another Broadband Bearer Capability MAY be tried.

**Table 4. Broadband Bearer Capability for UBR/ABR**

Field	Value
Bearer Class	16 (BCOB-X)
Traffic Type (for UNI 3.0 and 3.1 only)	0 (No Indication)
Timing Requirements (for UNI 3.0 and 3.1 only)	0 (No Indication)
Susceptibility to clipping	0 (Not susceptible to clipping)
User plane connection configuration	0 for point-to-point, 1 for point-to-multipoint
ATM Transfer Capability (SIG 4.0 only)	0x0C (ABR only) <sup>8</sup> Absent for UBR.

**3.3.3.8.6 Broadband Low Layer Information**

This information element<sup>9</sup> MUST be used in the SETUP or ADD PARTY message. It is used to indicate the protocol type carried in the connection and the purpose of the connection. LAN Emulation uses two different groups of B-LLI code points, one set of five for LAN Emulation non-multiplexed connections, and one code point for LAN Emulation LLC-multiplexed connections.

LAN Emulation v1 supports four unique frame formats. The two data frame formats are indicated as "ATM Forum LAN Emulation ... Ethernet/IEEE 802.3" and "ATM Forum LAN Emulation ... IEEE 802.5.". The "..." will be either "Data Direct" (for Data Direct VCCs) or "Multicast Send" or "Multicast Forward" (for Multicast VCCs). The control frame formats are indicated as "ATM Forum LAN Emulation Control." These encodings all use the ATM Forum's allocated 24-bit OUI. Note that an "ATM Forum LAN Emulation Ethernet/IEEE 802.3" format VCC may carry both IEEE 802.3 and Ethernet frames.

VCCs carrying frames in the LAN Emulation LLC-multiplexed format share a B-LLI code point with a number of other protocols' usages of ATM. This B-LLI code point indicates that every AAL5 frame carried on the VCC will begin with a 3-octet Logical Link Control sequence, defined in ISO 8802-2: ANSI/IEEE Std. 802.2 .

<sup>8</sup> Point to multipoint encoding for the user plane connection configuration field is NOT supported when requesting the ABR ATM service category.

<sup>9</sup>Reference: Section 5.4.5.9 of [5, 17, 25]

Table 5. Broadband Low Layer Information, Non-multiplexed VCCs

Field	Value
User information layer 3 protocol	11 (ISO/IEC TR 9577)
ISO/IEC TR 9577 Initial Protocol Identifier	64 (SNAP Identifier - 0x80, spread over 2 octets, left justified)
Continued from previous Octet	Continued (Ext bit is set to 1)
SNAP ID	0x80 (indicates SNAP and PID follow)
SNAP Organizational Unit Identifier	00 A0 3E (ATM Forum OUI)
PID	<p><b>0001</b> for LE Configuration Direct VCC, Control Direct VCC and Control Distribute VCC</p> <p><b>0002</b> for Ethernet/IEEE 802.3 LE Data Direct VCC</p> <p><b>0003</b> for IEEE 802.5 LE Data Direct VCC</p> <p><b>0004</b> for Ethernet/IEEE 802.3 LE Multicast Send VCC and Multicast Forward VCC</p> <p><b>0005</b> for IEEE 802.5 Multicast Send VCC and Multicast Forward VCC</p>

Table 6. Broadband Low Layer Information, LLC-multiplexed VCCs

Field	Value
User information layer 2 protocol	12 (LAN LLC [ISO8802/2])

LANE components SHOULD not include multiple B-LLI information elements in outgoing SETUP messages.

### 3.3.3.8.7 QoS Parameter

This information element<sup>10</sup> MUST be used in the SETUP message. For connections requesting UBR or ABR service categories, an LE Client MUST use Class 0. For other service categories, QoS Class 0 is recommended but a network specific value MAY be used.

### 3.3.3.8.8 Called Party Number

This information element<sup>11</sup> MUST be used in SETUP or ADD PARTY messages. This MUST be a 20 octet ATM Endsystem Address.<sup>12</sup> (See Section 5.1.3 of UNI 3.0 and UNI 3.1 and Section 3.0 of SIG 4.0).

### 3.3.3.8.9 Calling Party Number

This information element<sup>13</sup> MUST be used in the SETUP or ADD PARTY message sent by the calling party for LAN Emulation. This MUST be a 20 octet ATM Endsystem Address.<sup>14</sup> (See Section 5.1.3 of UNI 3.0 and UNI 3.1 and Section 3.0 of SIG 4.0).

<sup>10</sup>Reference: Section 5.4.5.18 of [5, 17, 25]

<sup>11</sup>Reference: Section 5.4.5.11 of [5, 17, 25]

<sup>12</sup> In UNI 3.0, "ATM Endsystem Addresses" are referred to as "OSI NSAP Addresses."

<sup>13</sup>Reference: Section 5.4.5.13 of [5, 17, 25]

<sup>14</sup> In UNI 3.0, "ATM Endsystem Addresses" are referred to as "OSI NSAP Addresses."

### 3.3.3.9 CONNECT Message Contents

The CONNECT message is formatted by the called party. It is received by the calling party. It is used primarily to confirm the connection and the values of any negotiable parameters.

#### 3.3.3.9.1 AAL Parameters

The called party MAY include the AAL Parameter information element in the CONNECT message.

If this information element is included, it MUST be checked to ensure that the parameters are unchanged or values that can be accepted. If not, the call MUST be released.

#### 3.3.3.9.2 ABR Setup Parameters Information Element

This information element MUST be present in the CONNECT message when establishing an ABR connection as described in Section 10 of [25].

#### 3.3.3.9.3 ATM Traffic Descriptor (SIG 4.0 Only)

The called user MUST include the ATM Traffic Descriptor information element in the CONNECT message.

A called user MUST request backward frame discard if provided in the SETUP message by including the backward frame discard indicators in the CONNECT message. Signalling procedures as described in Section 2.2.1 of UNI 4.0 Signalling MUST be followed.

When traffic parameter negotiation is requested, the called user MUST follow signalling procedures described in Section 8 of SIG 4.0.

Table 7 shows ATM traffic descriptor values for UBR and ABR.

**Table 7. ATM Traffic Descriptor In CONNECT Message for UBR/ABR**

Field	Value
Traffic Management Options Identifier	0xBF
Backward Frame Discard Indicator	1 (frame discard allowed in backward direction)
Forward Peak Cell Rate (CLP=0+1)	received value or adjusted when parameter negotiation is requested
Backward Peak Cell Rate (CLP=0+1)	received value or adjusted when parameter negotiation is requested
Forward ABR Minimum Cell Rate	received value or adjusted when parameter negotiation is requested
Backward ABR Minimum Cell Rate	received value or adjusted when parameter negotiation is requested

### 3.3.3.10 RELEASE, RELEASE COMPLETE and DROP PARTY Message Contents

LAN Emulation defines the use of the following Cause Codes to indicate why a VCC is being released. The following encoding is used when explicitly releasing a VCC:

**Table 8 RELEASE, RELEASE COMPLETE and DROP PARTY Cause Codes**

Cause Value	16 <sup>15</sup>	Normal call clearing
	31	Normal, Unspecified

<sup>15</sup>This code does not apply to UNI 3.0.

Other Cause Codes as specified in the UNI may be used under appropriate circumstances.

### 3.4 LAN Emulation to Layer Management Services

These services enable initialization and control of the LAN Emulation entities. These services differ between the LE Clients and the LE Service. A complete list of Initial State Parameters for LE Client and LE Server are listed in Section 5.

#### 3.4.1 LE Client Layer Management service

##### 3.4.1.1 LM\_LEC\_INITIALIZE.request

This primitive is used to configure the LE Client and cause it to join the emulated LAN.

The semantics of this primitive are as follows:

```
LM_LEC_INITIALIZE.request(
    LEC_ATM_address,
    Server_ATM_address,
    Unicast_LAN_Destination16
    Configure_mode,
    LEC_proxy_class,
    Explorer_frame_exclude,
    Selective_Multicast,
    Requested_LAN_type,
    Requested_max_frame_size,
    Requested_ELAN_name,
    Join_time-out
)
```

The LEC\_ATM\_address parameter specifies the Primary ATM address of the LE Client. The Server\_ATM\_address parameter specifies the ATM address of the LE Configuration Server (LECS) or the LE Server (LES) dependent on the Configure\_mode parameter and may be unspecified if the Configure\_mode parameter is "autoconfigure". If present, the unicast\_LAN\_Destination will be registered by the Join request. The Configure\_mode parameter may be "autoconfigure" or "manual" and it specifies if the LE Client will auto configure (i.e., attach to an LECS to discover the LES ATM address), or if it is manually configured in which case the Server\_ATM\_address specifies the ATM address of the LES. The LEC\_proxy\_class is specified as either "proxy" or "non-proxy". The Requested\_LAN\_type parameter may be "unspecified", "IEEE 802.3/Ethernet", or "IEEE 802.5 Token\_ring". The Requested\_max\_frame\_size parameter may be "unspecified", "1516 octets", "1580 octets", "4544 octets", "9234 octets", or "18190 octets". The Requested\_ELAN\_name may be "unspecified" or the name of the ELAN the client is to join. The Join\_time-out is the minimum time that the LE Client should wait for a response to its Configuration request or its Join request. The Explorer\_frame\_exclude parameter indicates whether or not the LE Client wants to receive Token Ring explorer frames other than those directed to one of its registered MAC addresses. Typically, only LE Clients on source route bridges are interested in receiving such frames. The Selective\_multicast parameter indicates whether or not the LE Client will register all multicast MAC addresses that it wants to receive individually with a LANE v2 LE Server.

The actual ATM AAL5 SDU size used in a call setup is extended by the length of the LANE LLC header, 12 octets, for LANE LLC-multiplexed VCCs only.

This primitive is generated by local management to cause the LE Client to join the ELAN.

The receipt of this primitive will cause the LE Client to stop operation (release all VCCs), to reset all its internal information, to update the specified parameters, and enter the INITIAL state. If the Configure\_mode parameter is

---

<sup>16</sup>Need not be present.

“autoconfigure”, then the LE Client will start the Configuration phase (5.3), and if it is “manual” the LE Client will start the Join phase (5.4).

#### 3.4.1.2 LM\_LEC\_INITIALIZE.confirm

This primitive is used to confirm the Initialize request and indicate if the LE Client’s user service interface is functional.

The semantics of this primitive are as follows:

```
LM_LEC_INITIALIZE.confirm (
    Join_status
)
```

The Join\_status parameter specifies success or the reason for failure of the Initialize request.

This primitive is generated by the LE Client to indicate the completion of the Initialization request. When the join status is “success,” the LE Client service user may start sending and receiving user data frames.

#### 3.4.1.3 LM\_LEC\_LD\_CONTROL.request

This primitive maintains the LE Client’s database of associated MAC addresses and route designators (i.e., the list of addresses the LE Client represents and for which it should receive frames). This primitive associates an action to an element of the database allowing the addition or removal of an element or the clearing of all elements of the same type and class.

In order for an LE Client to take advantage of LANE v2’s selective multicast service, it must maintain the list of multicast MAC addresses it wishes to receive. In addition, the LE client needs to support the LM\_LEC\_LD\_CONTROL primitive in order to allow an upper-layer protocol entity to specify the multicast MAC addresses to be received.

The semantics of this primitive are as follows:

```
LM_LEC_LD_CONTROL.request
(
    LD_action,
    LD_type,
    LD_proxy_class,
    LAN_destination_address
)
```

The LD\_action parameter is: add\_address, delete\_address, or clear\_list. The LD\_type parameter specifies multicast, unicast, or route\_designator. The LD\_proxy\_class parameter specifies either “proxy” or “local”. The LAN\_destination\_address specifies the address to add or delete. If the action is clear\_list, then the LE Client deletes all entries in the database whose attributes match the specified LD\_type and LD\_proxy\_class. If the local address is added before initialization, registration will occur.

The LAN\_destination\_address for a multicast or unicast LD\_type is a 48 bit MAC address. The LAN\_destination for a route\_designator LD\_type is a 16 bit route designator consisting of a 12 bit segment\_id and a 4 bit bridge\_number. Route designators apply to IEEE 802.5 Token Ring emulation and are not required for IEEE 802.3/Ethernet emulation.

This primitive may be generated by Layer Management to modify the LE Client’s address database.

Receipt of this primitive will cause the LE Client to add or delete the specified address and register the change with the LES as appropriate.

#### 3.4.1.4 LM\_LEC\_GET.request

This primitive is used by Layer Management to read the values of operational parameters/MIB variables.

The semantics of this primitive are as follows

```

LM_LEC_GET.request(
    Attribute_id
)

```

The Attribute\_id parameter specifies the attribute. The attribute may indicate any single variable/ group of variables available to be read by management.

This primitive is generated by Layer Management to read the LE Client's MIB.

Receipt of this primitive will cause the LE Client to generate a LM\_LEC\_STATUS.indication with the requested information.

#### 3.4.1.5 LM\_LEC\_SET.request

This primitive controls the operation of the LE Client by modifying its operational parameters.

The semantics of this primitive are as follows:

```

LM_LEC_SET.request(
    Attribute_id,
    Attribute_value
)

```

The Attribute\_id parameter specifies the attribute and the Attribute\_value specifies the new value. The Attribute may be any operational parameter or MIB variable that may be modified by management (see 4.1.1).

This primitive is generated by Layer Management to cause the LE Client to change operation.

Receipt of this primitive will cause the LE Client to change the specified attribute's value.

#### 3.4.1.6 LM\_LEC\_STATUS.indication

This primitive is used by the LE Client to report status to the Layer Management entity.

The semantics of this primitive are as follows:

```

LM_LEC_STATUS.indication(
    status_report
)

```

The status\_report parameter shall specify appropriate status, including statistics, error counts, etc. This primitive is generated by the LE Client when any of the following events occur: LE Service Up, LE Service Down, LM\_LEC\_GET.request, or LM\_LEC\_SET.request.

#### 3.4.1.7 LM\_LEC\_TOPOLOGY.request

This primitive controls the generation of LE Topology Request control frames to the LES and is used to notify other LE Clients of the topology change status. This primitive is invoked, for example, by an IEEE 802.1D transparent bridge when it sends a configuration BPDU.

The semantics of this primitive are as follows:

```

LM_LEC_TOPOLOGY.request(
    Topology_change_status
)

```

)

The Topology\_change\_status parameter is either "topology\_change" or "no\_topology\_change".

Receipt of this primitive will cause the LE Client to send a Topology Request control frame to the LES.

## 4. LAN Emulation Frame Formats

### 4.1 LE Data Frame

Two pairs of data frame formats are used by this specification.

The first pair is based on ISO 8802.3/CSMA-CD (IEEE 802.3) and has the format shown in Table 9 and Table 10 below. The minimum LAN Emulation AAL5 SDU length for LANE non-multiplexed IEEE 802.3/Ethernet format data frames is 62 octets, and for LANE LLC-multiplexed IEEE 802.3/Ethernet format data frames is 74 octets.

Table 9. LAN Emulation Non-multiplexed Data Frame Format for IEEE 802.3/Ethernet Frames

0	LE HEADER	DESTINATION ADDR
4	DESTINATION ADDRESS	
8	SOURCE ADDRESS	
12	SOURCE ADDR	TYPE/LENGTH
16 and on	INFO	

Table 10. LAN Emulation LLC-multiplexed Data Frame Format for IEEE 802.3/Ethernet Frames

0	LLC-X"AA"	LLC-X"AA"	LLC-X"03"	OUI-X"00"
4	OUI-X"A0"	OUI-X"3E"	FRAME-TYPE	
8	ELAN-ID			
12	LE HEADER	DESTINATION ADDR		
16	DESTINATION ADDRESS			
20	SOURCE ADDRESS			
24	SOURCE ADDR	TYPE/LENGTH		
28 and on	INFO			

The two frame formats differ only in that the LANE LLC-multiplexed frame has a 12-octet header. The LLC field is three bytes, containing the constant value X"AAAA03", indicating that an OUI follows. The OUI field is three octets, containing the constant value X"00A03E", indicating "ATM Forum". The next two bytes are a FRAME-TYPE field containing the value X"000C", indicating a LANE LLC-multiplexed IEEE 802.3/Ethernet data frame.

The ELAN-ID field identifies the emulated LAN for this data frame. It MUST be non-zero.

The length of the LE HEADER field is two octets, and it contains either the LECID value of the sending LE Client or X'0000'. The LAN frame check sequence, FCS, MUST NOT be included.



The second pair of frame formats is based on ISO 8802.5 (IEEE 802.5, or Token Ring) and has the formats shown in Table 11 and Table 12, below. The minimum LAN Emulation AAL5 SDU length for LANE non-multiplexed IEEE 802.5 format data frames is 16 octets, and for LANE LLC-multiplexed IEEE 802.5 format data frames is 28 octets.

**Table 11. LAN Emulation Non-multiplexed Data Frame Format for IEEE 802.5 Frames**

0	LE HEADER	AC PAD	FC
4	DESTINATION ADDRESS		
8	DESTINATION ADDR	SOURCE ADDRESS	
12	SOURCE ADDR		
16 UP TO 46	ROUTING INFORMATION FIELD		
	INFO		

**Table 12. LAN Emulation LLC-multiplexed Data Frame Format for IEEE 802.5 Frames**

0	LLC-X"AA"	LLC-X"AA"	LLC-X"03"	OUI-X"00"
4	OUI-X"A0"	OUI-X"3E"	FRAME-TYPE	
8	ELAN-ID			
12	LE HEADER	AC PAD	FC	
16	DESTINATION ADDRESS			
20	DESTINATION ADDR	SOURCE ADDRESS		
24	SOURCE ADDR			
28 UP TO 58	ROUTING INFORMATION FIELD			
	INFO			

The two frame formats differ only in that the LANE LLC-multiplexed frame has a 12-octet LLC multiplexing header. The LLC field is three octets, containing the constant value X"AAAA03", indicating that an OUI follows. The OUI field is three octets, containing the constant value X"00A03E", indicating "ATM Forum". The next two octets are a FRAME-TYPE field containing the value X"000D", indicating a LANE LLC-multiplexed IEEE 802.5 data frame.

The ELAN-ID field identifies the emulated LAN for this data frame.

The length of the LE HEADER field is two octets, and it also contains either the LECID value of the sending LE Client or X'0000'. The LAN frame check sequence, FCS, MUST NOT be included.

The AC PAD octet is not used in LAN Emulation. This MAY be set to any value on transmit and SHOULD be ignored on receipt.

LAN Emulation only allows LLC frames to be sent, therefore the FC octet **MUST** be of the form '01000YYY' binary, where 'YYY' is the priority set by the source LLC and **MAY** be recovered by the receiving LLC. This is described in [11].

The two LLC fields in a LANE LLC-multiplexed IEEE 802.5 frame must not be confused. The LLC multiplexing header that starts the frame has nothing to do with the LLC field that follows the source MAC address or (optional) RIF. That first LLC field, along with the OUI, FRAME-TYPE, and ELAN-ID, serve to identify the frame as belonging to one specific Emulated LAN, and allow one VCC to carry frames for multiple Emulated LANs, or even non-LANE traffic. The second LLC field, if present, describes the data contained in the IEEE 802 frame. When frames are bridged between traditional LANs and ATM LAN Emulation, the first LLC is added/stripped as the frame enters/leaves LAN Emulation. The second LLC field is carried through unchanged from the entry to the exit traditional LAN.

#### 4.1.1 Encoding of Ethernet/IEEE 802.3 Type/Length Fields

ATM LAN Emulation supports both IEEE 802.2 (LLC) data frames (see [8]) and DIX Ethernet EtherType frames (see [15]). Because an ATM Emulated LAN allows data frames larger than those allowed on traditional LANs, an LE Client **MUST** use the following rules to encode the Type/Length fields of data frames:

1. DIX Ethernet EtherType frames **MUST** be encoded by placing the EtherType field in the TYPE/LENGTH field. Data following the EtherType field follows the TYPE/LENGTH field immediately.
2. LLC data frames whose total length, including the LLC field and data, but not including any padding required to meet the minimum data frame length, (and not including the Frame Check Sequence, which is not used in ATM LAN Emulation), is less than 1536 (X"0600") **MUST** be encoded by placing that length in the TYPE/LENGTH field. The LLC field follows the TYPE/LENGTH field immediately.
3. LLC data frames longer than this maximum **MUST** be encoded by placing the value 0 in the TYPE/LENGTH field. The LLC field follows the TYPE/LENGTH field immediately.

When decoding data frames, the following rules **MAY** be used by an LE Client:

1. If the TYPE/LENGTH field is 1536 (X"0600") or greater, the frame is DIX Ethernet encoded. The TYPE/LENGTH field is the EtherType, and the data follows. The length of the data may be obtained from the AAL5 trailer, by subtracting the length of the frame through the TYPE/LENGTH field (16). On short frames, this length has a minimum value (46), so padding octets added to meet the minimum frame size cannot be identified at this level of decoding.
2. If the TYPE/LENGTH field is less than 1536 (X"0600"), the frame is an IEEE 802.2 LLC frame [8]. The LLC field immediately follows the TYPE/LENGTH field.
  - a. If the TYPE/LENGTH field is non-zero, it indicates the length of the data, starting with the LLC octets. Since this length does not include padding to meet the minimum data frame length requirement, such padding can be identified.
  - b. If the TYPE/LENGTH field is zero, then the length of the LLC data field may be obtained from the AAL5 trailer, by subtracting the length of the frame through the TYPE/LENGTH field (16)

## 4.2 LE Control Frames

All LAN Emulation control frames, except for LE\_FLUSH\_REQUESTs sent on LLC-multiplexed Data Direct VCCs, READY\_IND and READY\_QUERY, use the format described in Table 13. The format used for LE\_FLUSH\_REQUESTs sent on LLC-multiplexed VCCs is shown in Table 14 and for READY\_IND and READY\_QUERY in Table 42.

Table 13. LANE Control Frame

0	MARKER = X"FF00"		PROTOCOL = X"01"	VERSION = X"01"
4	OP-CODE		STATUS	
8	TRANSACTION-ID			
12	REQUESTER-LECID		FLAGS	
16	SOURCE-LAN-DESTINATION			
24	TARGET-LAN-DESTINATION			
32	SOURCE-ATM-ADDRESS			
52	LAN-TYPE	MAXIMUM- FRAME-SIZE	NUMBER-TLVs	ELAN-NAME- SIZE
56	TARGET-ATM-ADDRESS			
76	ELAN-NAME			
108	TLVs BEGIN			

Table 14. LANE LLC Multiplexed Control Frame (Flush Request Only)

0	LLC-"AA"	LLC-"AA"	LLC-"03"	OUI-"00"
4	OUI-"A0"	OUI-"3E"	FRAME-TYPE	
8	ELAN-ID			
12	MARKER = X"FF00"		PROTOCOL = X"01"	VERSION = X"01"
16	OP-CODE		STATUS	
20	TRANSACTION-ID			
24	REQUESTER-LECID		FLAGS	
28	SOURCE-LAN-DESTINATION			
36	TARGET-LAN-DESTINATION			
44	SOURCE-ATM-ADDRESS			
64	LAN-TYPE	MAXIMUM- FRAME-SIZE	NUMBER-TLVs	ELAN-NAME- SIZE
68	TARGET-ATM-ADDRESS			
88	ELAN-NAME			
120	TLVs BEGIN			

The fields common to all frame formats are described in Table 15.

In the two fields in a control frame where a LAN Destination is specified, the 8-octet format described in Table 16 MUST be used. The tag value "not present" MUST only be used where explicitly allowed for individual frame formats and protocols. MAC addresses and Route Designators are in their "natural" bit/octet order, LSB for Ethernet/IEEE 802.3 or MSB for IEEE 802.5, according to the emulated LAN type.

Note that the LLC-multiplexed control frame format is used only for the LE\_FLUSH\_REQUEST message over LLC-multiplexed VCCs. All other control messages use the non-multiplexed control frame format.

Where the emulated LAN type is undetermined, Ethernet/IEEE 802.3 bit ordering **MUST** be used. There are only three cases where the LAN type may be undetermined:

1. LE\_CONFIGURE\_REQUEST, LAN-TYPE=0
2. LE\_CONFIGURE\_RESPONSE, LAN-TYPE=0
3. LE\_JOIN\_REQUEST, LAN-TYPE=0

**Table 15. Control Frame Header Format**

Offset Non Muxed	Size	Name	Function
0	2	MARKER	Control Frame = X"FF00"
2	1	PROTOCOL	ATM LAN Emulation protocol = X"01"
3	1	VERSION	ATM LAN Emulation protocol version = X"01"
4	2	OP-CODE	Control frame type: See Table 19 for a list of values.
6	2	STATUS	Always X"0000" in requests. See Table 18 for a list of values.
8	4	TRANSACTION-ID	Arbitrary value supplied by the requester and returned by the responder to allow the receiver to discriminate between different responses.
12	2	REQUESTER-LECID	LECID of LE Client sending the request (X"0000" if unknown).
14	2	FLAGS	Bit flags. See Table 17 for a list of values.
16	92	Meaning of remainder of fields depends on OP-CODE.	

**Table 16. LAN Destination Field Format**

Offset	Size	Name	Function
0	2	TAG	X"0000" = not present X"0001" = MAC address X"0002" = Route Descriptor
2	6	MAC Address	6-octet MAC address if MAC address specified.
2	4	RESERVED	0, if Route Descriptor specified.
6	2	Route Descriptor	If Route Descriptor specified.

The Route Descriptor has the coding form 'LLLLLLLLLLLLBBBB' binary, where 'LLLLLLLLLLLL' is the LAN\_ID and 'BBBB' is the Bridge number. This is also described in Annex B.2.2.

**Table 17. Control Frame FLAGS Values**

Hex	Name	Use
X"0001"	Remote Address	LE_ARP_RESPONSE, LE_ARP_REQUEST

X"0002"	V2 Capable	LE_CONFIG_REQUEST, LE_JOIN_REQUEST
X"0004"	Selective Multicast	LE_JOIN_REQUEST
X"0008"	V2 Required	LE_JOIN_RESPONSE
X"0080"	Proxy Flag	LE_JOIN_REQUEST
X"0100"	Topology Change	LE_TOPOLOGY_REQUEST
X"0200"	Token Ring Explorer Exclude	LE_JOIN_REQUEST

Table 18. Control Frame STATUS Values

Code (dec)	Name	Meaning	Responses
0	Success	Successful response	All responses
1	Version Not Supported	VERSION field of request contains a value higher than that supported by the responder.	All responses
2	Invalid request parameters	The parameters given are incompatible with the ELAN.	All responses
4	Duplicate LAN Destination registration	SOURCE-LAN-DESTINATION duplicates a previously-registered LAN Destination	Join or Register
5	Duplicate ATM address	SOURCE-ATM-ADDRESS duplicates a previously-registered ATM address.	Join or Register
6	Insufficient resources to grant request	Responder is unable to grant request for reasons such as insufficient table space or ability to establish VCCs.	Configure, Join or Register
7	Access denied	Request denied for security reasons.	Configure or Join
8	Invalid REQUESTOR-ID	LECID field is not zero (Configure or Join) or is not LE Client's LECID (others).	Configure, Join, Register, Unregister, ARP
9	Invalid LAN Destination	LAN Destination is a multicast address	Configure, Join, Flush
		A Route Descriptor on an Ethernet/802.3 ELAN	Configure, Join, Register, ARP, Flush
10	Invalid ATM Address	Source or Target ATM Address not in a recognizable format or not valid.	Configure, Join, Register, ARP, Flush, Verify
20	No Configuration	LE Client is not recognized.	Configure
21	LE_CONFIGURE Error	Parameters supplied give conflicting answers. May also be used to refuse service without giving a specific reason.	Configure
22	Insufficient Information	LE Client has not provided sufficient information to allow the LECS to assign it to a specific ELAN	Configure
24	TLV Not Found	There are no TLVs present in the set of TLVs for this emulated LAN that can be returned with the Config-Frag-Info TLV passed in the LE_CONFIGURE_REQUEST message.	Configure

## 4.3 Control Frame Usage

### 4.3.1 Discarding Invalid Frames

For the purposes of determining validity, a control frame is a frame which has the value X"FF00" in its MARKER field, X"01" in its PROTOCOL field, X"01" in its VERSION field and a value from Table 19 in its OP-CODE field.

A data frame is a frame that has a value between X"0000" and X"FEFF" inclusive in its LE-HEADER field.

The B-LLI code point value used in establishing a VCC determines whether or not the 12-octet LANE LLC-multiplexed header is present. All frames on a VCC established with the "LLC Multiplexing" (Table 6) code point MUST have the 12-octet LANE LLC-multiplexed header. All frames on a VCC established with one of the five

LANE non-multiplexed B-LLI code points (Table 5) **MUST NOT** have the 12-octet LANE LLC-multiplexed header. Any frame which violates the B-LLI coding rules for the VCC on which it is carried is an invalid frame. Note that a receiving entity cannot reliably distinguish frames which violate the B-LLI coding rules; genuinely ambiguous bit sequences can be constructed which are valid frames for both non-multiplexed and LLC-multiplexed VCCs.

A LAN Emulation component that receives any frame that is not, by these definitions, either a data frame or a control frame, **MUST** discard that frame<sup>17</sup>, except that

1. An LE Server **MAY** relay such a frame from a Control Direct VCC to a Control Distribute or Control Direct VCC, and
2. A BUS **MAY** relay such a frame from a Multicast Send VCC to the associated Multicast Forward VCCs.

#### 4.3.2 Transmitting the LANE LLC-Multiplexed Header

A LAN Emulation component **MUST NOT** transmit a frame with the 12-octet LANE LLC-Multiplexed header to a VCC established with one of the five LANE Non-Multiplexed B-LLI code points. A LAN Emulation component **MUST NOT** transmit a frame without the 12-octet LANE LLC-multiplexed header to a VCC established with the "LLC-multiplexing" B-LLI code point.

#### 4.3.3 Request/Response Field Usage

In the tables describing the contents and usage of control frames, some fields are explicitly defined as having different values in request and response frames. All fields whose descriptions are not so differentiated **MUST** be copied verbatim from the request frame to the response frame by any LAN Emulation component that responds to a request. Note that a different rule applies to TLVs (see Section 4.3.11 below).

#### 4.3.4 FLAGS Field Usage

Section 4.3.3 notwithstanding, in order to ensure future extensibility of this standard, all FLAGS bits not defined in Table 17 **MUST** be transmitted as 0 and **MUST** be ignored on receipt.

#### 4.3.5 Sender/Receiver Field Usage

In the tables describing control frame field usage, the terms sender and receiver refer to the component performing the transmission or reception of the AAL5 SDU in question.

#### 4.3.6 Response Frame Routing

An LE Server **MUST** direct any response frame (control frame with X"01" in the most-significant octet of its OP-CODE field) it receives to at least that LE Client (if any) whose LECID matches the response frame's REQUESTER-LECID field. If the LECID of an LE\_FLUSH\_RESPONSE frame is unknown (i.e., does not match the LECID of any LE Client), an LE Server **MUST** forward the frame to at least all LE Clients that successfully joined as proxy clients.

#### 4.3.7 Agreement of Response Frame Destinations

An LE Server **MAY** discard without re-transmitting an LE\_ARP or FLUSH response frame if its SOURCE-ATM-ADDRESS field and its REQUESTER-LECID field indicate two different LE Clients. An LE Server **MAY** discard without re-transmitting an LE\_ARP response frame if its SOURCE-ATM-ADDRESS field and its REQUESTER-LECID field do not indicate an operational LE Client in the emulated LAN. An LE Server **MUST** forward a FLUSH response frame to at least all LE Clients that successfully joined as proxy agents if the REQUESTER-LECID field does not indicate an operational LE Client in the emulated LAN.

---

<sup>17</sup> Discarding these control frames should not cause an LE Client to generate a response frame.

#### 4.3.8 Request Frame Source Identification

An LE Client MUST either put one of its ATM addresses or put 0 in the SOURCE-ATM-ADDRESS field of every request frame (control frame with X"00" in the most-significant octet of its OP-CODE field) that it transmits. It MUST NOT put zero in the SOURCE-ATM-ADDRESS field in any control frame other than an LE\_NARP\_REQUEST, LE\_TOPOLOGY\_CHANGE or LE\_VERIFY\_REQUEST frame. It MUST put its LECID in every request frame except for those that require a 0 LECID (i.e. LE\_CONFIGURE\_REQUEST and LE\_JOIN\_REQUEST).

#### 4.3.9 Response Frame Filtering

An LE Client MUST discard any LE\_CONFIGURE\_RESPONSE, LE\_JOIN\_RESPONSE, or LE\_FLUSH\_RESPONSE frame in which neither the SOURCE-ATM-ADDRESS nor the REQUESTOR-LECID identify that LE Client. It MAY discard any response frame in which either of those two fields does not identify the LE Client, except that only the SOURCE-ATM-ADDRESS field is used on LE\_CONFIGURE\_RESPONSE and LE\_JOIN\_RESPONSE frames.

#### 4.3.10 ELAN-ID Filtering

An LE Client MUST discard any frame received whose ELAN-ID specifies a value not corresponding to the one ELAN served/used by that LE Client. Note that, when multiple LE Clients share the same ATM Address, the ELAN-ID field MUST be used to determine to which component a frame is directed.

#### 4.3.11 TLVs in Requests/Responses

An LE Client, LE Server (or BUS), or LE Configuration Server may reply to a request control frame with a response control frame. Either the request frame, the response frame, or both, may include TLVs. Any of those TLVs may or may not be understood by the requesting or responding LANE component. When responding to a request, a LANE component MUST ensure that any TLVs in the response frame convey information from the responder to the requestor, and MUST NOT echo TLVs from the request to the response that it does not understand. A responder may accomplish this, for example, by processing the TLVs in a request frame, deleting all of them, and then supplying the TLVs, if any, necessary for the response.

#### 4.3.12 Badly-Formatted TLVs

Any LANE component SHOULD discard any frame received if its NUMBER-TLVs field contains a non-zero value and any TLV has a TYPE field containing all 0s. Any LANE component SHOULD discard any frame received if its NUMBER-TLVs field contains a non-zero value and the TLVs extend beyond the end of the frame as defined by that frame's PDU size.



## 4.3.13 Summary of OP-CODEs

Table 19. OP-CODE Summary

OP-CODE Value	OP-CODE Function
X"0001"	LE_CONFIGURE_REQUEST
X"0101"	LE_CONFIGURE_RESPONSE
X"0002"	LE_JOIN_REQUEST
X"0102"	LE_JOIN_RESPONSE
X"0003"	READY_QUERY
X"0103"	READY_IND
X"0004"	LE_REGISTER_REQUEST
X"0104"	LE_REGISTER_RESPONSE
X"0005"	LE_UNREGISTER_REQUEST
X"0105"	LE_UNREGISTER_RESPONSE
X"0006"	LE_ARP_REQUEST
X"0106"	LE_ARP_RESPONSE
X"0007"	LE_FLUSH_REQUEST
X"0107"	LE_FLUSH_RESPONSE
X"0008"	LE_NARP_REQUEST
X"0108"	Undefined
X"0009"	LE_TOPOLOGY_REQUEST
X"0109"	Undefined
X"000A"	LE_VERIFY_REQUEST
X"010A"	LE_VERIFY_RESPONSE

## 4.4 Byte and Bit Order

The convention used to describe LAN Emulation frame formats in this document is to express numbers in decimal and to picture data in "big-endian" order. That is, fields are described left to right, with the most significant octet on the left and the least significant octet on the right.

The order of transmission to the AAL5 layer of the header and data described in this document is resolved to the octet level. Whenever a diagram shows a group of octets, the order of transmission of those octets is the normal order in which they are read in English. For example, in the following diagram the octets are transmitted in the order they are numbered.

0	1	2	3
0 1 2 3 4 5 6 7	8 9 0 1 2 3 4 5	6 7 8 9 0 1 2 3	4 5 6 7 8 9 0 1
1	2	3	4
5	6	7	8
9	10	11	12

**Transmission Order of Bytes**

Whenever an octet represents a numeric quantity the left most bit in the diagram is the high order or most significant bit. That is, the bit labeled 0 is the most significant bit. For example, the following diagram represents the value 170 (decimal).

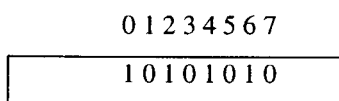

**Significance of Bits**

Similarly, whenever a multi-octet field represents a numeric quantity the left most bit of the whole field is the most significant bit. When a multi-octet quantity is transmitted the most significant octet is transmitted first. Hexadecimal values are indicated by the notation X", e.g. X"0101" = decimal 257.

### 4.5 Media Format of MAC Addresses

An IEEE 48 bit MAC address is a 48 bit binary number. The I/G bit indicates if the address is a unicast (I/G=0) or multicast (I/G=1) address. Conventional Ethernet and Token Ring LANs differ in that Ethernet transmits the lsb (least significant bit) of each octet first and Token Ring transmits the msb (most significant bit) of each octet first. Because of this difference, the format of the 48 bit MAC address in memory is different for these two media access methods. The following tables show the formats used for 48 bit MAC addresses in Ethernet and Token Ring LAN Emulation. The format used is determined by the LAN Type parameter. The selected format is used for both LE Data Frames and LE Control Frames.

Table 20. Formats for IEEE 48 bit MAC Address Based on LAN Type

Ethernet:	Data Bits							
	msb	d6	d5	d4	d3	d2	d1	lsb
Octet 1	b7	b6	b5	b4	b3	b2	b1	I/G
Octet 2	b15	b14	b13	b12	b11	b10	b9	b8
Octet 3	b23	b22	b21	b20	b19	b18	b17	b16
Octet 4	b31	b30	b29	b28	b27	b26	b25	b24
Octet 5	b39	b38	b37	b36	b35	b34	b33	b32
Octet 6	b47	b46	b45	b44	b43	b42	b41	b40

Token Ring:	Data Bits							
	msb	d6	d5	d4	d3	d2	d1	lsb
Octet 1	I/G	b1	b2	b3	b4	b5	b6	b7
Octet 2	b8	b9	b10	b11	b12	b13	b14	b15
Octet 3	b16	b17	b18	b19	b20	b21	b22	b23
Octet 4	b24	b25	b26	b27	b28	b29	b30	b31
Octet 5	b32	b33	b34	b35	b36	b37	b38	b39
Octet 6	b40	b41	b42	b43	b44	b45	b46	b47

## 5. Initialization Protocols, Procedures and Frame Formats

The initialization of an LE Client is divided into an Initial state (Section 5.1) and five phases: LECS Connect phase (5.2), Configuration phase (5.3), Join phase (0), Initial Registration phase (5.5), and BUS Connect phase (5.6). These five phases **MUST** be performed in sequence, starting with the LECS Connect phase. Following the completion of the BUS Connect phase, the initialization procedure is complete, and the LE Client is *operational*. If the initialization phase or the operational state terminates abnormally the LE Client **MUST** return to the Initial state and inform layer management.

All five phases of the initialization procedure are required for an LE Client to expect to achieve full interoperability. *Note: Provision is made for the LECS Connect and Configuration phases to be empty, so that their functions can be bypassed for certain applications. The Initial Registration phase is also an empty phase if the LE Client can perform all needed address registration during the Join phase.*

### 5.1 Initial State

#### 5.1.1 Initial State - LE Client View

The initial state of the LE Client is determined by means outside the scope of this document. The state of the variables defined in this section after the orderly termination of an LE Client, or its abnormal termination from any initialization or operational phase, is an implementation issue not addressed in this specification.

Certain of the parameters, below, contain “minimum”, “maximum”, and/or “default” values. A variable **MUST NOT** be set to a value smaller than its minimum value or larger than its maximum value. Most ATM Emulated LANs, if composed entirely of LAN Emulation components compliant with this specification, and whose components’ variable values are set to the default values, should operate correctly. The behavior of specific configurations may be optimized by altering the values away from the defaults, but such optimization is beyond the scope of this specification. Values outside the specified minima and maxima are likely to result in an emulated LAN that functions poorly or not at all for many applications.

The following parameters apply to each LE Client:

- C1n** **LE Client’s Non-Multiplexed ATM Addresses.** The list of all of the LE Client’s own ATM Addresses that will accept non-multiplexed VCCs. The LE Client’s primary ATM address is the first ATM address in C1. The primary ATM address used to connect to the LES and the BUS **MUST** be known before the Configuration and Join phases can start, and **MUST NOT** change without restarting the Configuration and Join phases. The Primary ATM address **MUST** be used to establish the LE Client’s Control Direct and Multicast VCCs, and **MUST** be specified as the SOURCE-ATM-ADDRESS in the client’s LE\_JOIN\_REQUESTs. An LE Client **MAY** have additional ATM addresses in C1n for use with Data Direct VCCs. These additional addresses do not need to be known at Join time, and can be removed from service without restarting the Join phase. The ATM addresses in C1n **MAY** be disjoint from, identical to, or overlap those in C1m in any manner.
- C1m** **LE Client’s LLC-Multiplexed ATM Addresses.** The list of all of the LE Client’s own ATM Addresses that will accept LLC-multiplexed VCCs. The LE Client’s primary ATM address **MAY** be included in C1m. C1m **MUST** be empty in an operational LE Client unless the LE Client’s variable C34 is set. The addresses in C1m do not need to be known at Join time, and can be removed from service without restarting the Join phase. The ATM addresses in C1m **MAY** be disjoint from, identical to, or overlap those in C1n in any manner.
- C2** **LAN Type.** The type of LAN that the LE Client is, or wishes to become, a member of. This **MUST** be one of Ethernet/IEEE 802.3, IEEE 802.5, or Unspecified. **MUST NOT** be Unspecified after a successful Join. This parameter **MUST NOT** be changed without terminating the LE Client and returning to the Initial state. This variable **MUST** be initialized to C2c at the beginning of the Configure phase.
- C2c** **LAN Type (configured).** The configured type of LAN that the LE Client wishes to become. This variable **MUST NOT** be overwritten by an LE\_CONFIGURE\_RESPONSE or an LE\_JOIN\_RESPONSE.

- C3 Maximum Data Frame Size.** The maximum AAL5 SDU size of a data frame that the LE Client wishes to send on any Multicast Send VCC or to receive on any Multicast Send VCC or Multicast Forward VCC. This parameter also specifies the maximum AAL5 SDU of all of an LE Client's Data Direct non-multiplexed VCCs, and specifies the smallest maximum AAL5 SDU - 12 of the LLC-multiplexed Data Direct VCCs. This MUST be either 1516, 1580, 4544, 9234, or 18190 octets, or Unspecified. MUST NOT be Unspecified after a successful Join. MUST NOT be changed without terminating the LE Client and returning it to the Initial state. **C3 Maximum Data Frame Size** MUST NOT take the value 1580 unless the variable **C29 V2 Capable** is set. This variable MUST be initialized to **C3c** at the beginning of the Configure phase.
- C3c Maximum Data Frame Size (configured).** The configured maximum AAL5 SDU size of a data frame that the LE Client wishes to send or receive. This is the AAL5 SDU size - 12 for LLC-multiplexed VCCs. This variable MUST NOT be overwritten by a LE\_CONFIGURE\_RESPONSE or a LE\_JOIN\_RESPONSE.
- C4 Proxy.** This indicates whether the LE Client may have remote unicast MAC addresses in **C27** or remote route descriptors in **C30**. For example, an IEEE 802.1D transparent bridge MUST NOT register with the LE Server the MAC addresses of the endstations on its other LAN segments. MUST be known before the Join phase can start. This parameter MUST NOT change without restarting the Configuration phase.
- C5 ELAN Name.** The identity of the emulated LAN the LE Client wishes to join, or to which the LE Client last joined. MAY be unspecified before Join. Never unspecified after a successful Join. Formatted as an SNMPv2 DisplayString of length 0-32 octets. MAY have a zero length after a successful Join. The ELAN Name client parameter and ELAN\_NAME field in the Join protocol provide a way to configure clients with human-readable strings for network management purposes. This variable MUST be initialized to **C5c** at the beginning of the Configure phase.
- C5c ELAN Name (configured).** The configured identity of the emulated LAN the LE Client wishes to join. This variable MUST NOT be overwritten by an LE\_CONFIGURE\_RESPONSE or a LE\_JOIN\_RESPONSE.
- C6 Local Unicast MAC Address(es).** Each LE Client has zero or more local unicast MAC addresses. In an operational LE Client, every address in this variable MUST have been registered with the LE Server. Two LE Clients joined to the same emulated LAN MUST NOT have the same local unicast MAC address. An LE Client's MAC addresses may change during normal operations. When answering an LE\_ARP\_REQUEST for any address in this list, the "Remote Address" bit in the FLAGS field of the LE\_ARP\_RESPONSE MUST be clear.
- C7 Control Time-out.** Time out period used for timing out most request/response control frame interaction. Control time-out consists of an initial time-out of **C7i**, a retry multiplier (or logarithmic back-off base) **C7x** and a cumulative maximum time-out with values as follows:  
Value: Minimum=10 seconds, Default=30 seconds, Maximum=300 seconds.  
Note: **C7** should be less than **S4**. Also, **C7i** and **C7x** should be set such that such that one iteration will succeed.
- C7i Initial Control Time-out.**  
Value: Minimum=1 second, Default=5 seconds, Maximum=10 seconds.
- C7x Control Time-out Multiplier.**  
Value: Minimum=2, Default=2, Maximum=5
- C8 Local Route Descriptor(s).** Route Descriptors exist only for source-routed IEEE 802.5 LE Clients that are Source-Route Bridges. All Local Route Descriptors in any given emulated LAN MUST be unique. An LE Client MAY have zero or more Local Route Descriptors and these Local Route Descriptors MAY change during normal operation. In an operational LE Client, every Local Route Descriptor in **C8** MUST have been registered with the LE Server. When answering an LE\_ARP\_REQUEST for any address in this list, the "Remote Address" bit in the FLAGS field of the LE\_ARP\_RESPONSE MUST be clear.
- C9 LE Server ATM Address.** The ATM address of the LAN Emulation Server is used to establish the Control Direct VCC. This is obtained in the Configuration phase. This address MUST be known before the Join phase can start.
- C10 Maximum Unknown Frame Count.**

Value: Minimum=1, Default=10, Maximum=20. (See parameter **C11 Maximum Unknown Frame Time**.)

- C11 Maximum Unknown Frame Time.** Within the period of time defined by the Maximum Unknown Frame Time, an LE Client will send no more than Maximum Unknown Frame Count frames to the BUS for a given unicast or multicast LAN Destination without initiating the address resolution protocol to resolve that LAN Destination.

Value: Minimum=1 second, Default=1 second, Maximum=60 seconds.

- C12 VCC Time-out Period.** An LE Client SHOULD release any Data Direct VCC that it has not been used to transmit or receive any data frames for the length of the VCC Time-out Period. This parameter is only meaningful for SVC Data Direct VCCs signalled with the Ethernet/IEEE 802.3 LE Data Direct VCC B-LLI value or the IEEE 802.5 LE Data Direct VCC B-LLI value. It SHOULD NOT be used for any SVC signalled with the LLC Multiplexed B-LLI value.

Value: Minimum=None specified, Default=20 minutes, Maximum=Unlimited.

- C13 Maximum Retry Count.** An LE Client MUST not retry an LE\_ARP\_REQUEST for a given frame's LAN Destination more than Maximum Retry Count times, after the first LE\_ARP\_REQUEST for that same frame's LAN Destination.

Value: Minimum=0, Default=1, Maximum=2.

- C14 LE Client Identifier.** Each LE Client requires an LE Client Identifier (LECID) assigned by the LE Server during the Join phase. The LECID is placed in control requests by the LE Client and MAY be used for echo suppression on multicast data frames sent by that LE Client. This value MUST NOT change without terminating the LE Client and returning to the Initial state. A valid LECID MUST be in the range X"0001" through X"FEFF" inclusive.

- C15 LE Client Multicast MAC Address(es).** An LE Client MUST maintain a list of multicast MAC addresses which it currently wishes to receive and pass up to the higher layers. The broadcast address SHOULD be included in this list. If **C32** is set, all MAC addresses in this list MUST be registered with the LE Server except for the broadcast address. This list may be manipulated by means of the LM\_LEC\_LD\_CONTROL primitives. In an operational LE Client, if variable **C32** is set, every address in **C15**, except for the broadcast address, MUST have been registered with the LE Server. An LE Client's multicast MAC addresses may change during normal operations.

- C16 LE\_ARP Cache.** A table of entries, each of which establishes a relationship between a unicast or multicast LAN Destination external to the LE Client and the ATM address to which data frames for that LAN Destination will be sent. If **C29 V2 Capable** is set, then the relationships between multicast MAC addresses and ATM addresses are also maintained in the LE\_ARP Cache. In addition to the ATM address binding information, the LE\_ARP cache must also maintain TLV information associated with the cached addresses.

- C17 Aging Time.** The maximum time that an LE Client will maintain a unicast LAN Destination in its LE\_ARP cache in the absence of a verification of that relationship.

Value: Minimum=10 seconds, Default=300 seconds, Maximum=300 seconds.

- C18 Forward Delay Time.** The maximum time that an LE Client will maintain an entry for a non-local MAC address in its LE\_ARP cache in the absence of a verification of that relationship, as long as the Topology Change flag **C19** is set.

Value<sup>18</sup>: Minimum=4 seconds, Default=15 seconds, Maximum=30 seconds.

- C19 Topology Change.** Boolean indication that the LE Client is using the Forward Delay Time **C18**, instead of the Aging Time **C17**, to age non-local entries in its LE\_ARP cache **C16**.

- C20 Expected LE\_ARP Response Time.** The maximum time that the LE Client expects an LE\_ARP\_REQUEST / LE\_ARP\_RESPONSE cycle to take. Used for retries and verifies.

Value: Minimum=1 second, Default=1 second, Maximum=30 seconds.

---

<sup>18</sup>This is consistent with IEEE 802.1D, Table 4-3.

- C21 Flush Time-out.** Time limit to wait to receive an LE\_FLUSH\_RESPONSE after the LE\_FLUSH\_REQUEST has been sent before taking recovery action.  
Value: Minimum=1 second, Default=4 seconds, Maximum=4 seconds.
- C22 Path Switching Delay.** The time since sending a frame to the BUS after which the LE Client may assume that the frame has been either discarded or delivered to the recipient. May be used to bypass the Flush protocol.  
Value: Recommend: Minimum=1 second, Default=6 seconds, Maximum=8 seconds.
- C23 Local Segment ID.** The 12 bit segment ID of the emulated LAN in the binary format 0000SSSSSSSSSSSS. This is only required for IEEE 802.5 LE Clients that are Source Routing bridges. This is the source routing Segment ID for the emulated LAN and is used as outlined in the Source Routing Section 2.4.8 (Source Routing Considerations) and Appendix B.2 (Token Ring Source Routing Information and Structures).
- C23c Local Segment ID (configured).** The configured value of the C23 Local Segment ID variable. This variable MUST NOT be overwritten by an LE\_JOIN\_RESPONSE.
- C24 Default Multicast Send VCC Type.** Signalling parameter that SHOULD be used by the LE Client when establishing the Default Multicast Send VCC. This is the method to be used by the LE Client when specifying traffic parameters when it sets up the Default Multicast Send VCC for this emulated LAN.
- C25 Default Multicast Send VCC AvgRate.** Signalling parameter that SHOULD be used by the LE Client when establishing the Default Multicast Send VCC. Forward and Backward Sustained Cell Rate to be requested by LE Client when setting up Default Multicast Send VCC, if using Variable bit rate codings.
- C26 Default Multicast Send VCC PeakRate.** Signalling parameter that SHOULD be used by the LE Client when establishing the Default Multicast Send VCC. Forward and Backward Peak Cell Rate to be requested by LE Client when setting up the Default Multicast Send VCC when using either Variable or Constant bit rate codings.
- C27 Remote Unicast MAC Address(es).** The MAC addresses for which this LE Client will answer LE\_ARP\_REQUESTs, but which are not registered with the LE Server. This list MUST be empty in any operational LE Client that did not join the emulated LAN as a proxy agent (C4 Proxy). When answering an LE\_ARP\_REQUEST for any address in this list, the "Remote Address" bit in the FLAGS word of the LE\_ARP\_RESPONSE MUST be set.
- C28 Connection Completion Timer.** Optional. In Connection Establishment this is the time period in which data or a READY\_IND message is expected from a Calling Party.  
Value: Minimum=1 second, Default=4 seconds, Maximum=10 seconds.
- C29 V2 Capable.** If set, the LE Client MUST exhibit LANE v2 behavior where it differs in its requirements from LANE v1 behavior. If clear, the LE Client MUST exhibit LANE v1 behavior in these cases. (Other sections of this document reference variable C29 as appropriate.) This variable is set or cleared according to the state of the V2 Required FLAGS bit in the LE\_JOIN\_RESPONSE. This variable MUST be initialized to C29c at the beginning of the Join phase.
- C29c V2 Capable (configured).** The configured value of the C29 V2 Capable variable. This variable MUST NOT be overwritten by an LE\_JOIN\_RESPONSE.
- C30 Remote Route Descriptor(s).** The Route Descriptors for which this LE Client will answer LE\_ARP\_REQUESTs, but which are not registered with the LE Server. This list MUST be empty in any operational LE Client that did not join the emulated LAN as a proxy agent (C4 Proxy). When answering an LE\_ARP\_REQUEST for any address in this list, the "Remote Address" bit in the FLAGS word of the LE\_ARP\_RESPONSE MUST be set. Route Descriptors exist only for source-routed IEEE 802.5 LE Clients that are Source-Route Bridges.
- C31 ELAN ID.** The ELAN-ID to be used in all LANE LLC-multiplexed data frames sent or received by this LE Client. Takes the value "0" if the LE Server named in C9 is a LANE v1 LE Server. This variable may be set by the LE\_JOIN\_RESPONSE. The initial value of this variable is "0".
- C32 Selective Multicast.** This indicates whether or not the LE Client will register to receive specific multicast destination MAC addresses. If C32 Selective Multicast is set, the LE Client MUST issue an LE\_REGISTER\_REQUEST for all of the multicast or group MAC addresses in C15, except for the broadcast MAC address. If this variable is clear, the LE Client MUST NOT issue an

LE\_REGISTER\_REQUEST for any multicast MAC address and can expect to receive all multicast frames from the BUS. **C32 Selective Multicast** MUST NOT be set if **C29 V2 Capable** is clear. This variable MUST be initialized to **C32c** at the beginning of the Join phase.

- C32c Selective Multicast (configured).** This is the configured value of the **C32** variable. **C32c Selective Multicast (configured)** MUST NOT be set if **C29c V2 Capable (configured)** is clear.
- C33 Forward Disconnect Time-out.** If the LE Client detects that the BUS has had no Multicast Forward VCCs to the LE Client for time Forward Disconnect Time-out, the LE Client MUST disconnect from the BUS and try to re-establish a new connection.  
Value: Minimum = 10 seconds, Default = 60 seconds, Maximum = 300 seconds.
- C34 LLC-Multiplex Capable.** If set, this variable indicates that the LE Client can accept and process LLC-multiplexed Data Direct VCCs. If clear, it indicates that the LE Client will refuse to accept LLC-multiplexed Data Direct VCCs. This variable MUST be clear if the LE Client is connected to a LANE v1 LES. This variable MUST NOT be set if **C29 V2 Capable** is clear. This variable MUST be initialized to **C34c** at the beginning of the Configure phase.
- C34c LLC-Multiplex Capable (configured).** This is the configured value of the **C34** variable. **C34c LLC-Multiplex Capable (configured)** MUST NOT be set if **C29c V2 Capable (configured)** is clear.
- C35 Preferred LES Address.** The ATM address of the preferred LE Server. This variable is set during the Configuration phase by copying the contents of the Preferred LES TLV received in the LE\_CONFIGURE\_RESPONSE.
- C36 L3 Address(s).** The Layer 3 address that is to be used in the Layer-3-Address TLV during the Initialization phase.
- C37 Minimum Reconfigure Delay.** The minimum time that an LE Client must wait before retrying configuration.  
Value: Minimum=1 millisecond, Default=1 millisecond, Maximum=C38.
- C38 Maximum Reconfigure Delay.** The maximum time that an LE Client must wait before retrying configuration.  
Value: Minimum=C37, Default=5 seconds, Maximum=10 seconds.
- C39 Maximum BUS Connect Retries.** The maximum number of times that an LE Client can try to establish the Default Multicast Send VCC before returning to the configuration procedure.  
Value: Minimum=0, Default=1, Maximum=2.
- C40 Token Ring Explorer Frame Exclude.** This indicates whether or not the LE Client wishes to receive token ring explorer frames other than those directed to one of its registered MAC addresses. Normally, only bridges need to receive such explorer frames. This parameter only applies to token-ring ELANs. This parameter MUST NOT change without restarting the configure phase.

### 5.1.2 Initial State - LE Service View

The following parameters apply per emulated LAN served by an LE Service:

- S1 LE Server's ATM Address.** The LE Server MUST know its own ATM Address for LE Clients to be able to establish a connection to it. The ATM address cannot be changed as long as any LE Client is connected to the LE Server.
- S2 LAN Type.** The type of this ATM Emulated LAN, either Ethernet/IEEE 802.3 or IEEE 802.5.
- S3 Maximum Data Frame Size.** The maximum AAL5 SDU size of a data frame that the LE Service can guarantee not to drop because it is too large. Also the minimum AAL5 SDU size that every LE Client must be able to receive. This MUST be either 1516, 1580, 4544, 9234, or 18190 octets.
- S4 Control Time-out.** Time out period used for timing out most request/response control frame interactions, as specified elsewhere. Once an LE Client establishes a Control Direct VCC to the LE Server, the Join



phase must complete within the Join Time-out time. If not, the LE Service SHOULD release any Control VCCs to that LE Client, terminating the Join phase.

Value: Minimum=10 seconds, Default=120 seconds, Maximum=300 seconds.

- S5 Maximum Frame Age.** The BUS MUST discard a frame if it has not transmitted the frame to all relevant Default or Selective Multicast Send VCCs or Multicast Forward VCCs within the Maximum Frame Age following the BUS's receipt of the frame over any Multicast Send VCC.

Value: Minimum=1 second, Default=1 second, Maximum=4 seconds.

- S6 Broadcast and Unknown Server's ATM Address(es).** A Broadcast and Unknown Server MUST know at least one of its own ATM addresses for LE Clients to be able to establish connections to it. A Broadcast and Unknown Server MAY have several ATM addresses. Addresses MAY be added while the BUS is operational, but MAY NOT be removed as long as any LE Client is connected to the BUS through them.

- S7 ELAN-ID.** The ELAN-ID to be used in all LANE LLC-multiplexed data frames sent or received on this ELAN. It is returned to the LE Clients during the Configure and/or Join phases.

- S8 Local Segment ID.** The segment ID of the emulated LAN. This is only required for IEEE 802.5 ELANs. This is the source routing Segment ID for the emulated LAN, and is passed to LE Clients in the LE\_JOIN\_RESPONSE.

- S9 Send Disconnect Time-out.** If the BUS detects that an LE Client has had no Default Multicast Send VCC to the BUS for time Send Disconnect Time-out, the LE Service MAY terminate the LE Client.

Value: Minimum=10 seconds, Default=60 seconds, Maximum= 300 seconds.

## 5.2 LECS Connect Phase

During the LECS Connect phase, the LE Client establishes its connection with the LE Configuration Server.

### 5.2.1 LECS Connect - LE Client View

An LE Client MAY be configured to bypass the LECS Connect phase entirely, if and only if it is also configured to bypass the Configure phase. An LE Client MUST be able to be configured to perform the LECS Connect phase. The mechanisms used to locate the configuration service are as follows, in the order in which an LE Client MUST attempt them:

1. Use Preconfigured LECS address, if available
2. Get the LECS Address via ILMI
3. Use the well-known LECS Address

These mechanisms are described in the following paragraphs:

#### 5.2.1.1 Preconfigured LECS Address

The LE Client MAY be configured with an LECS address. The LE Client MUST attempt to establish a Configuration Direct VCC to this address. If there is not a preconfigured address or the Configuration Direct VCC can not be established, the LE Client should proceed to the following step. An LE Client MUST be capable of being configured to operate without a preconfigured LECS address, as described in the following sections.

#### 5.2.1.2 The LE Client Gets LECS Address via ILMI

The LE Client MUST issue an ILMI Get or GetNext to obtain the ATM address of the LECS for that UNI. If the UNI connection to the obtained address fails, the LE Client MUST issue an ILMI Get or GetNext request to determine if an additional LE Configuration Server ATM address is available, and attempt to establish the Configuration Direct VCC to those ATM addresses in sequence until one is successful or all fail. The ILMI MIB table to be read to obtain the LECS ATM Address is defined in the MIB in [24].

#### 5.2.1.3 Well-known LECS Address

If the LECS ATM address cannot be obtained from ILMI or if the LE Client is unable to establish a Configuration Direct VCC to that address, then the well-known address X"05079000000000000000000000000000-00A03E000001-00" MUST be used to open a configuration VCC to the configuration service. 00 A0 3E is the ATM Forum-assigned

OUI and 000001 has been allocated by the ATM Forum. If the LE Client cannot establish a VCC to the well-known address specified above, the LE Client MUST attempt to establish a VCC to the well-known address specified [23] (X"4700790000000000000000000000-00A03E000001-00").

#### 5.2.1.4 Configuration Direct VCC

The LE Client MUST attempt to establish a Configuration Direct VCC using the call parameters for LE Configuration Direct VCCs defined in Table 5. The called party address MUST be the ATM addresses obtained as above. The calling party address may be any valid ATM address belonging to the end station. If the attempt to establish the Configuration Direct VCC fails and the LE Client wants to retry configuration, the LE Client MUST delay an amount of time randomly selected from the interval [C37,C38] before initiating the retry.

### 5.2.2 LECS Connect - LE Service view

#### 5.2.2.1 Finding At Least One LECS

The provider of the LAN Emulation service MUST ensure that an LE Client following the rules of section 5.2.1 will be able to connect to an LE Configuration Server.

Note: Some UNI implementations might not allow the LECS to register the Well-Known LECS Address as one of its valid addresses. Furthermore, the Interim Interswitch Signalling Protocol (IISP), will route calls addressed to the Well-Known LECS Address only toward a static set of switches. In these cases, the LE Clients might not be able to connect to an LE Configuration Server using this address.

#### 5.2.2.2 Finding the Correct LECS

If an LE Client is able to establish a Configuration Direct VCC, then the LECS Connect phase has completed successfully, whether or not the LE Client is able to complete the Configuration phase. Therefore, the LAN Emulation service SHOULD ensure that the state does not persist where an LE Client can connect to a "dead" LE Configuration Server.

## 5.3 Configuration Phase

During the Configuration phase, the LE Client (or other entity) obtains the ATM Address of the LE Server, and may obtain additional configuration parameters. Configuration control frames are of two types:

- **LE\_CONFIGURE\_REQUEST**: Sent by the LE Client or other interested party to the LECS to obtain configuration information.
- **LE\_CONFIGURE\_RESPONSE**: Sent by the LE Configuration Server in response to an **LE\_CONFIGURE\_REQUEST**. MUST be a LANE non-multiplexed format frame.

The configuration phase prepares an LE Client for the Join phase by providing the necessary operating parameters for the emulated LAN which the client will later join.

An LE Client MAY be configured using static parameters, instead of using the Configuration phase. In this case, the LECS Connect phase MAY be bypassed. If the LE Client bypasses the Configuration Phase, the client variables **C2c**, **C3c**, **C5c**, **C29c**, and **C32c** SHOULD be copied to **C2 LAN Type**, **C3 Maximum Data Frame Size**, **C5 ELAN Name**, **C9**, **C29**, and **C32**, respectively before the start of each Join Phase. An LE Client MUST be able to be configured to utilize the Configuration phase described in this section.

The LE Configuration protocol allows the assignment of individual LE Clients to different emulated LANs and provides information about the operating parameters of that LAN. Based on its own policies, configuration databases and information provided by clients, an LE Configuration Server assigns any client which requests configuration information to a particular LE Service entity by giving it the LE Server's ATM address and other parameters.

This protocol assumes that the requesting entity already knows how many LE Clients to instantiate. An end-station may request configuration information separately for each LE Client and/or MAC address it represents. The LE Configuration Server returns the ELAN-ID and the address of an LE server which is suitable, given the supplied information.

It is expected that the LAN Emulation Configuration protocol will be used for more purposes than the one of a non-bridge LE Client discovering which ELAN it should join. For example, a bridge or concentrator supporting multiple LE Clients, and representing multiple traditional LAN endstations, may determine which of its LE Clients (ELANs) should be bound to which of its traditional endstations, based on the endstations' MAC addresses.

### 5.3.1 Configuration - Requester's View

This section is described in terms of a "requester" which has established a Configuration Direct VCC, and is issuing LE\_CONFIGURE\_REQUESTs and receiving LE\_CONFIGURE\_RESPONSEs, and a "prospective LE Client" on whose behalf the requests are being made. In the case of an LE Client configuring itself, these two entities are one and the same. In other cases, they may be different.

#### 5.3.1.1 Configure Request

The requester MUST issue a LANE LE\_CONFIGURE\_REQUEST to the LE Configuration Server containing the primary ATM Address of the prospective LE Client in the SOURCE-ATM-ADDRESS field. The LE\_CONFIGURE\_REQUEST MUST also contain the variable C2c and C5c in the LAN-TYPE and ELAN-NAME fields, respectively. The MAXIMUM-FRAME-SIZE field MUST be set according to Section 5.3.1.2. The request MAY contain a LAN Destination from the prospective LE Client's C6 or C8 variables in the SOURCE-LAN-DESTINATION field. If the LE Client's C36 L3 Address is not empty, then the L3 Address TLV MUST be included in the request with a value specifying the C36 L3 Address. The "V2 Capable" FLAGS bit SHOULD come from C29c. The X05 Adjustment TLV SHOULD come from C3c.

#### 5.3.1.2 MAXIMUM-FRAME-SIZE Compatibility with V1

LANE v2 introduces a new MAXIMUM-FRAME-SIZE value, X"05", for 1580/1592-octet frames. In order to retain compatibility with a LANE v1 LECS, the MAXIMUM-FRAME-SIZE field value X"05" is handled in a special manner. The MAXIMUM-FRAME-SIZE field MUST NOT contain the value X"05" (1580/1592) in an LE\_CONFIGURE\_REQUEST. Table 21 gives the encodings that the LE Client MUST use to express its preference for MAXIMUM-FRAME-SIZE. Note that the LE Client can express its preference for the new X"05" (1580/1592) frame size in two ways, one which will be interpreted by a LANE v1 LECS as X"01" (1516/1528), and one which will be interpreted by a LANE v1 LECS as X"02" (4544/4556).

Table 21. MAXIMUM-FRAME-SIZE V1/V2 Adjustment

MAXIMUM-FRAME-SIZE in Request or Response	X5 Adjustment TLV in Request or Response*	"V2 Capable" FLAGS bit in Request†	v1 component understands SDU size is:	v2 component understands SDU size is:
X"00"	present or not	set or clear	Unspecified	Unspecified
X"01"	not present	set or clear	1516	1516/1528
X"01"	present	set	1516	1580/1592
X"01"	present	clear	1516	1580/1592
X"02"	not present	set or clear	4544	4544/4556
X"02"	present	set	4544	1580/1592
X"02"	present	clear	4544	1580/1592
X"03"	present or not	set or clear	9234	9234/9246
X"04"	present or not	set or clear	18190	18190/18202
X"05" ‡	present or not	set	ILLEGAL	1580/1592
X"05" ‡	present or not	clear	ILLEGAL	ILLEGAL

\* The X5-Adjustment TLV MUST NOT be present in an LE\_JOIN\_RESPONSE frame. In this frame type, the MAXIMUM-FRAME-SIZE value X"05" MUST be used to represent an SDU size of 1580/1592 octets.

† The value of the "V2 Capable" FLAGS bit in the Request frame determines the legality of the parameters in the Request frame itself, and in the corresponding Response frame. The presence or absence of this bit is not meaningful in the response frame, itself. This bit determines the legality of the combinations of the other parameters; it does not determine the SDU size.

‡ X"05" MUST NOT be encoded in an LE\_CONFIGURE\_REQUEST frame.

### 5.3.1.3 Unsuccessful Configure Response

If the LE\_CONFIGURE\_RESPONSE does not contain 0 (Success) in the STATUS field, then the Configuration phase has failed for the prospective LE Client. If this answer is not satisfactory, e.g. in the case of an LE Client configuring itself, the LE Client MUST return to the beginning of the Initialization procedure after a delay randomly selected from the interval [C37,C38] if it wishes to re-attempt to configure itself.

### 5.3.1.4 Successful Configure Response

If the LE\_CONFIGURE\_RESPONSE does contain 0 (Success) in the STATUS field, then the Configuration phase has succeeded for the prospective LE Client. In this case, the LAN-TYPE, MAXIMUM-FRAME-SIZE, and ELAN-NAME parameters MUST be copied to the prospective LE Client's C2 LAN Type, C3 Maximum Data Frame Size and C5 ELAN Name variables, respectively. The MAXIMUM-FRAME-SIZE and X5-Adjustment TLV MUST both be used according to Table 21 to set the value of C3 Maximum Data Frame Size. The ELAN-ID returned in a TLV MUST be copied to the prospective LE Client's C31 variable if it is returned, else the C31 variable MUST be set to 0. The TARGET-ATM-ADDRESS MUST be copied to the LE Client's C9 variable. Client's C2c, C3c, C5c, C9c, C29c and C32c MUST remain unmodified.

If the Preferred LES TLV was included as part of the LE\_CONFIGURE\_RESPONSE then the LE Client MUST extract that TLV and copy it to the LE Client's C35 Preferred LES Address. The contents of C35 Preferred LES Address must be included as a part of the LE\_JOIN\_REQUEST that the LE Client will send to the LES whose address it has just received from the LECS.

### 5.3.1.5 Configure Response TLV Encodings

Table 24 illustrates the LE\_CONFIGURE\_REQUEST and LE\_CONFIGURE\_RESPONSE Type-Length-Value (TLV) encodings. A requester MUST recognize the values listed in this table and transfer any values returned in a successful LE\_CONFIGURE\_RESPONSE to the corresponding variables in the prospective LE Client.

### 5.3.1.6 Fragmentation of TLV Data in Configure Responses

To allow the requestor to obtain TLV information that will not fit into a single response frame, the LECS can fragment TLV data for an emulated LAN. The LECS MUST include any LUNI 1.0 ATM Forum TLVs in the first LE\_CONFIGURE\_RESPONSE sent to any LE Clients AND any LE Client which understands the Config-Frag-Info TLV MUST respect this TLV by making additional LE\_CONFIGURE\_REQUESTS.

The fragmentation protocol makes use of an ATM Forum Type TLV in the LE\_CONFIGURE\_RESPONSE and of the (same) TLV in the LE\_CONFIGURE\_REQUEST.

When an LECS has more TLV data available than will fit into a single response, it will pack as many of the TLVs into the frame as possible. The last TLV packed into each frame will be the ATM Forum Type Config-Frag-Info and the STATUS field will be set to zero. The Config-Frag-Info TLV has a VALUE field with a maximum length of 255 bytes. The data in this field is opaque to LE Clients.

An LECS receiving a LE\_CONFIGURE\_REQUEST with a TLV containing the Config-Frag-Info TLV MUST generate an LE\_CONFIGURE\_RESPONSE that matches the original response with the exception that it contains the same TRANSACTION-ID and different TLV data. By inspecting the supplied Config-Frag-Info TLV, the LECS is able to compute which TLV data it should supply in response to this new request.

If an LECS does not support this fragmentation protocol or is returning all TLVs in a single LE\_CONFIGURE\_RESPONSE frame, then it MUST omit the Config-Frag-Info TLV in the LE\_CONFIGURE\_RESPONSE. This is the default LANE v1 behavior.

An LE Client receiving an LE\_CONFIGURE\_RESPONSE with a Config-Frag-Info TLV present MUST obtain further TLV information by issuing another LE\_CONFIGURE\_REQUEST with a new TRANSACTION-ID, including the unmodified Config-Frag-Info TLV returned in the previous LE\_CONFIGURE\_RESPONSE.

### 5.3.1.7 Retrying Configure Request

If the LE Configuration Server does not return an LE\_CONFIGURE\_RESPONSE within the Initial Control Time-out period, the requester MUST multiply the current time-out value by the time-out multiplier and retry the LE\_CONFIGURE\_REQUEST, resetting the timer for the new time-out. This process is repeated each time the Control Time-out timer expires until the cumulative time has exceeded the maximum cumulative time-out value associated with C7 Control Time-out. Note that at least one retry must occur before disconnecting the Configuration Direct VCC. Each time the request is retried, all fields - except for the TRANSACTION-ID field - MUST be identical to the same field in the previous request. If no LE\_CONFIGURE\_RESPONSE is obtained by the time the cumulative waiting time period exceeds the maximum cumulative time-out value (associated with C7 Control Time-out), then the Configuration phase has failed. If the LE Client wishes to re-attempt a LE\_CONFIGURE\_REQUEST at this point, it MUST return to the beginning of the Initialization procedure after a delay randomly selected from the interval [C37,C38].

### 5.3.1.8 Releasing the Configuration Direct VCC

Following completion of the Configuration Phase, the LE Client SHOULD release the Configuration Direct VCC with normal indication. If the Configuration Direct VCC is released by the LECS before the LE Client has completed the configuration phase, then the LE Client MUST restart the configuration phase, ignoring any configuration information returned to that point by the LECS.

At any time, the requester MAY release the Configuration Direct VCC. Any number of whole or partial exchanges of LE\_CONFIGURE\_REQUEST and LE\_CONFIGURE\_RESPONSE frames, including 0, may occur before the Configuration Direct VCC is released. If the LE Client wishes to re-attempt configuration at this point, it MUST return to the beginning of the Initialization procedure after a delay randomly selected from the interval [C37,C38].

### 5.3.1.9 Configure Response Ordering

Because the LECS is not required to return LE\_CONFIGURE\_RESPONSEs in the same order that the corresponding LE\_CONFIGURE\_REQUESTs were sent, a requester that issues multiple requests SHOULD use the TRANSACTION-ID field to distinguish between responses to different requests.

## 5.3.2 Configuration - LE Service View

The LE Configuration Server uses the information provided in the LE\_CONFIGURE\_REQUEST to generate an LE\_CONFIGURE\_RESPONSE. This response may indicate success or failure, depending on whether the prospective LE Client is to be allowed to attempt to join an LE Server.

### 5.3.2.1 Requester's ATM Address

The calling party's ATM address used in signalling the Configuration Direct VCC MUST NOT be considered by the LECS in determining which ELAN to direct the requester to, but MAY be used in deciding whether or not to respond and/or release the connection for security reasons.

### 5.3.2.2 LAN-TYPE Configure Response

If the LAN-TYPE in the LE\_CONFIGURE\_REQUEST is not Unspecified, then the LAN-TYPE in the LE\_CONFIGURE\_RESPONSE MUST have the same value as that in the LE\_CONFIGURE\_REQUEST. If the LAN-TYPE in the LE\_CONFIGURE\_REQUEST is Unspecified, then the LAN-TYPE in the LE\_CONFIGURE\_RESPONSE MAY have any value listed in Table 22.

### 5.3.2.3 MAXIMUM-FRAME-SIZE Configure Response

If the MAXIMUM-FRAME-SIZE in the LE\_CONFIGURE\_REQUEST is not Unspecified, then the MAXIMUM-FRAME-SIZE in the LE\_CONFIGURE\_RESPONSE MUST have the same value as, or represent a lower SDU size value than, the value in the LE\_CONFIGURE\_REQUEST, but MUST NOT be Unspecified. If the MAXIMUM-FRAME-SIZE in the LE\_CONFIGURE\_REQUEST is Unspecified, then the MAXIMUM-FRAME-SIZE in the LE\_CONFIGURE\_RESPONSE MAY have any value listed in Table 22. The value of MAXIMUM-FRAME-SIZE, the "V2 Capable" FLAGS bit, and the presence or absence of the X5 Adjustment TLV MUST be used by the LECS according to Table 21 to interpret the LE\_CONFIGURE\_REQUEST and to generate the LE\_CONFIGURE\_RESPONSE. An LECS MAY reject an LE\_CONFIGURE\_REQUEST with an illegal combination of values according to Table 21. If the LE\_CONFIGURE\_REQUEST's "V2 Capable" FLAGS bit was clear, then the LECS MUST NOT send the X5 Adjustment TLV, nor return a value of X"05" in the MAXIMUM-FRAME-SIZE, in the LE\_CONFIGURE\_RESPONSE.

#### 5.3.2.4 ELAN-ID Configure Response

The LECS SHOULD return an ELAN-ID. The ELAN-ID value returned MUST be the same for all LE Clients on the same ELAN, and MUST be unique over all ELANs supported by the LECS.

#### 5.3.2.5 LES ATM Address Configure Response

If returning a successful LE\_CONFIGURE\_RESPONSE, an LECS MUST return the ATM address of an LES capable of serving a Control Direct VCC in the TARGET-ATM-ADDRESS field.

#### 5.3.2.6 Preferred LES TLV

If the LE Client has a "preferred" LES associated with it, and that LES is functional, then the LECS MUST return the ATM address of that LES when sending a LE\_CONFIGURE\_RESPONSE message to the LE Client. If the "preferred" LES is non-functional, the LECS MUST return the address of a different LES in the same ELAN, if such an LES is available. It MUST also include the Preferred LES TLV as part of the response. If an LE Client has no "preferred" LES associated with it then the LECS will return the ATM address of a LES in the LE Client's ELAN, but will not include the Preferred LES TLV. The LE Client's C35 Preferred LES Address will hold the contents of this TLV.

#### 5.3.2.7 Configure Response Ordering

The LECS MAY issue LE\_CONFIGURE\_RESPONSES in a different order than that in which the corresponding LE\_CONFIGURE\_REQUESTS were received, even for LE\_CONFIGURE\_REQUESTS received on the same Configure Direct VCC.

#### 5.3.2.8 TLV Not Present

When a Config-Frag-Info TLV is contained in an LE\_CONFIGURE\_REQUEST, the LECS will, if it can respond to that TLV, return one or more TLVs in the subsequent LE\_CONFIGURE\_RESPONSE message. If the Config-Frag-Info TLV contained in the LE\_CONFIGURE\_REQUEST message can not be used to select one or more additional TLVs by the LECS, then the LECS SHOULD set STATUS in the LE\_CONFIGURE\_RESPONSE message to "TLV Not Found."

#### 5.3.2.9 First Configuration Response Contents

The LECS MUST include any LANE v1 ATM Forum TLVs in the first Configuration Response sent to any LE Clients. The LECS SHOULD NOT include any partial set of TLVs in the first Configuration Response - e.g. a simplistic LECS would send ONLY LANE v2 ATM Forum TLVs in the first Configuration Response.

#### 5.3.2.10 Configuration vs. Operation

The set up or release of a Configuration Direct VCC by an LE component, or any exchange of LE\_CONFIGURE\_REQUEST or LE\_CONFIGURE\_RESPONSE frames, MUST NOT affect the operational status of any LE Client.

#### 5.3.2.11 Releasing the Configuration Direct VCC

An LECS MUST ensure that during a reconfiguration, the outcome of a configuration request is not determined by an intermediate state. The LECS MAY choose to release all VCCs and refuse to accept any new VCCs during a reconfiguration. If an existing VCC is released then the cause value MUST be "normal, unspecified" and the cause value for refusing a connection attempt MUST be "temporary failure." An LECS MAY release an established Configuration Direct VCC if required to free resources for an Configuration Direct VCC connection request. If an existing VCC is released then the cause value MUST be "resource unavailable, unspecified."

## 5.3.3 Configuration Frames

The format of each AAL5 SDU for LE Configuration Request and LE Configuration Response frame is as follows:

Table 22. Configuration Frame Format

Offset	Size	Name	Function
0	2	MARKER	Control Frame = X"FF00"
2	1	PROTOCOL	ATM LAN Emulation protocol = X"01"
3	1	VERSION	ATM LAN Emulation protocol version = X"01"
4	2	OP-CODE	Type of request: X"0001" LE_CONFIGURE_REQUEST X"0101" LE_CONFIGURE_RESPONSE
6	2	STATUS	Always X"0000" in requests. See Table 18 for a list of values.
8	4	TRANSACTION-ID	Arbitrary value supplied by the requester and returned by the responder.
12	2	REQUESTER-LEC-ID	Always X"0000" in requests, ignored on response.
14	2	FLAGS	Each bit of the FLAGS field has a separate meaning if set: X"0002" V2 Capable Flag: LE Client's C29c variable is set (request only).
16	8	SOURCE-LAN-DESTINATION	MAC address or Route Descriptor of prospective LE Client. MAY be encoded as "not present."
24	8	TARGET-LAN-DESTINATION	Always X"0000" when sent, ignored on receipt.
32	20	SOURCE-ATM-ADDRESS	Primary ATM address of prospective LE Client for which information is requested.
52	1	LAN-TYPE	X"00" Unspecified <sup>19</sup> X"01" Ethernet/IEEE 802.3 X"02" IEEE 802.5

<sup>19</sup>If the LAN-TYPE is "unspecified," then the Ethernet/IEEE 802.3 MAC address format MUST be used.

53	1	MAXIMUM-FRAME-SIZE	<p>X"00" Unspecified</p> <p>X"01" 1516 (non-muxed VCCs) or 1528 (LLC-muxed VCCs) if the "V2 Capable" FLAGS bit is clear or if the X5 Adjustment TLV is not present. 1580 (non-muxed VCCs) or 1592 (LLC-muxed VCCs) if the "V2 Capable" FLAGS bit is set and the X5 Adjustment TLV is present.</p> <p>X"02" 4544 (non-muxed VCCs) or 4556 (LLC-muxed VCCs) if the "V2 Capable" FLAGS bit is clear or if the X5 Adjustment TLV is not present. 1580 (non-muxed VCCs) or 1592 (LLC-muxed VCCs) if the "V2 Capable" FLAGS bit is set and the X5 Adjustment TLV is present.</p> <p>X"03" 9234 (non-muxed VCCs) or 9246 (LLC-muxed VCCs)</p> <p>X"04" 18190 (non-muxed VCCs) or 18202 (LLC-muxed VCCs)</p>
54	1	NUMBER-TLVs	Number of Type/Length/Value elements encoded in Request/Response.
55	1	ELAN-NAME-SIZE	Number of octets in ELAN-NAME (may be 0).
56	20	TARGET-ATM-ADDRESS	If Configure Response and STATUS="Success," ATM Address of LE Server for the LE Client described in the request, else 0.
76	32	ELAN-NAME	Name of emulated LAN <sup>20</sup> .
108	4	ITEM_1-TYPE	Three octets of OUI, one octet identifier.
112	1	ITEM_1-LENGTH	Length in octets of VALUE field. Minimum=0.
113	Variable	ITEM_1-VALUE	
		Etc.	

Further parameters may be included by either the requester or the configuration server, encoded using Type/Length/Value (TLV) where present, in order to accommodate servers with user-defined and optional extensions. As many parameters may be included as will fit into the maximum SDU size negotiated on the Configuration Direct VCC.

In Type Field, OUI designates the authority responsible for allocating the four octet value of a Type value. The OUI value 00-A0-3E is used for standard values defined by the ATM Forum specification. No padding is in the TLV field. Zero, one, or more TLV fields may be present.

Further vendor-specific extensions may be implemented by servers using the OUI of the vendor defining the extensions. The first three octets of a TYPE value MUST contain an OUI. The last octet of a TYPE value should be used to distinguish between different parameters defined by an organization.

### 5.3.4 Configuration Request Frame - Supported TLVs

The following tables lists the TLVs which are supported by the LE\_CONFIGURE\_REQUEST message. See Annex A for Parameter Encodings.

<sup>20</sup>SNMPv2 DisplayString



**Table 23. Configuration Request Frame - Supported TLVs**

TLV Name	Version
Layer-3-Address	LANE v2
X5-Adjustment	LANE v2
Config-Frag-Info	LANE v2

### 5.3.5 Configuration Response Frame - Supported TLVs

The following table lists the TLVs which are supported by the LE\_CONFIGURE\_RESPONSE message. See Annex A for Parameter Encodings.

An LE Client MUST update its operational parameter set with these values if it can parse them. An LE Client MUST ignore any encoded 'Type' values which it does not understand. The Value provided for any parameter is in the same units as defined in Section 5.1 and the References are to that same section where appropriate.

**Table 24. Configuration Response Frame - Supported TLVs**

Item	Version
Max-Cumulative-Control-Time-out	LANE v1
Max-Unknown-Frame-Count	LANE v1
Max-Unknown-Frame-Time	LANE v1
VCC-Time-out-Period	LANE v1
Max-Retry-Count	LANE v1
Aging-Time	LANE v1
Forward-Delay-Time	LANE v1
Expected-LE_ARP-Response-Time	LANE v1
Flush-Time-out	LANE v1
Path-Switching-Delay	LANE v1
Local-Segment-ID	LANE v1
Default-Mcast-Send-VCC-Type	LANE v1
Default-Mcast-Send-VCC-AvgRate	LANE v1
Default-Mcast-Send-VCC-PeakRate	LANE v1
Connection-Completion-Timer	LANE v1
Config-Frag-Info	LANE v2
ELAN-ID	LANE v2
X5-Adjustment	LANE v2
Preferred-LES	LANE v2

## 5.4 Join Phase

During the Join phase, the LE Client establishes its connection(s) with the LE Server and determines the operating parameters of the emulated LAN. The LE Client also may implicitly register one unicast LAN Destination with the LE Server as a result of joining the emulated LAN.

- **LE\_JOIN\_REQUEST:** Sent by the LE Client to the LE Server. Requests that the LE Client be allowed to join an ATM Emulated LAN.
- **LE\_JOIN\_RESPONSE:** Sent by the LE Server to the LE Client in response to an LE\_JOIN\_REQUEST frame. Confirms or denies the join request.

Address registrations performed in the Join phase are limited in functionality compared to address registrations made using LE Register control frames; no TLVs can be passed with the implicit registration. In particular, this means that an LE Client cannot register an LLC-multiplexing capable ATM address in a Join request. No multicast or functional MAC addresses may be registered during the Join phase.

These frame formats are described in Table 25.

### 5.4.1 Join Phase - LE Client View

#### 5.4.1.1 Establishing the Control Direct VCC

An LE Client MUST initiate and complete UNI signalling procedures to establish a point-to-point bi-directional Control Direct VCC between its LE Client's primary ATM address C1 and the LE Server ATM address C9. If the LE Client cannot establish this connection, then it MUST terminate the Join procedure. The SETUP request for this VCC MUST be signalled using the call parameters defined in Section 3.3, using the B-LLI code point for Control Direct VCCs. The calling party ATM Address used by the LE Client when setting up the Control Direct VCC MUST be the LE Client's primary ATM Address.

#### 5.4.1.2 Transmitting LE\_JOIN\_REQUEST

The LE Client MUST send an LE\_JOIN\_REQUEST over the Control Direct VCC. The LE\_JOIN\_REQUEST MUST include the LE Client variables C2 LAN Type, C4 Proxy, and C5 ELAN Name, C29c, C32c and C40 variables, as well as the primary ATM address from LE Client variable C1. The value of C29c V2 Capable (configured) MUST be the same as in the LE\_CONFIGURE\_REQUEST. The value of the MAXIMUM-FRAME-SIZE field and the presence or absence of the X5-Adjust TLV MUST correspond, according to Table 21, to C3 Maximum Frame Size. The LE\_JOIN\_REQUEST MAY include one unicast LAN Destination from C6 Local Unicast MAC Address(es) or C8 Local Route Descriptor(s) to be registered with the SOURCE-ATM-ADDRESS and no TLVs. If the LE Client received a Preferred-LES TLV from the LECS as part of the LE\_CONFIGURE\_RESPONSE then it MUST copy the contents to C35 Preferred LES Address and include the contents of C35 Preferred LES Address in the Preferred-LES TLV as part of the LE\_JOIN\_REQUEST. With the exception of the X5-Adjust and Preferred-LES TLVs mentioned above, the LE\_JOIN\_REQUEST MUST include the same TLVs as were included in the LE\_CONFIGURE\_REQUEST. The LE Client MUST NOT set the V2 Required bit in the FLAGS word of an LE\_JOIN\_REQUEST. The LE Client MUST send an LE\_JOIN\_REQUEST within the Initial Control Time-out period associated with C7 Control Time-out.

#### 5.4.1.3 Accepting Control Distribute

Once the LE Client sends the LE\_JOIN\_REQUEST, the LE Client MUST accept an attempt by the LE Server to establish a Control Distribute VCC to that LE Client's primary ATM address, if that attempt is made before the LE\_JOIN\_RESPONSE is returned by the LE Server. This VCC SETUP Indication will be signalled with the call parameters defined in Section 3.3 for LE Control Distribute VCCs. An LE Client SHOULD refuse any attempt to establish a second or subsequent Control Distribute VCC.

#### 5.4.1.4 Receiving LE\_JOIN\_RESPONSE

The LE Server returns an LE\_JOIN\_RESPONSE to the LE Client. The LE\_JOIN\_RESPONSE may be returned on either the LE Client's Control Direct VCC or its Control Distribute VCC (if created). The LE Client MUST be prepared to receive it on either VCC. The LE Client MUST be prepared to receive and ignore LE\_JOIN\_RESPONSE frames or any other control frames on either Control VCC that are not directed to itself.

#### 5.4.1.5 Receiving on Control Distribute VCC

If the LE Server establishes a Control Distribute VCC, then the LE Client **MUST** be prepared to receive control frames over the Control Distribute VCC. The SETUP request for this VCC **MUST** be signalled using the call parameters defined in Section 3.3 LE Control Direct VCCs.

#### 5.4.1.6 Future Control Distribute VCC Establishment

Once the LE Client receives an LE\_JOIN\_RESPONSE from the LE Server, if the LE Server has not established a Control Distribute VCC, then the LE Client **MAY** assume that no Control Distribute VCC will be established by that LE Server, no matter what the status of the LE\_JOIN\_RESPONSE, and **MAY** refuse the connection if the LE Server attempts to make it.

#### 5.4.1.7 Validating LE\_JOIN\_RESPONSE

If the LE\_JOIN\_RESPONSE indicates a successful join, the LE Client **MUST** update its variables **C2 LAN Type**, **C3 Maximum Data Frame Size**, **C5 ELAN Name**, and **C14** according to the information in the LE\_JOIN\_RESPONSE. (The value for **C5 ELAN Name** may be zero length.) The LE Client **MUST** clear its variable **C32** if the V2 Required FLAGS is clear in the LE\_JOIN\_RESPONSE. The LE Client **MUST** obtain the value for **C3 Maximum Data Frame Size** according to Table 21. The LE Client **MUST** set or clear its variable **C29** according to the state of the V2 Required FLAGS bit. The LE Client **MUST** either update these variables from the values given by the LE Server, or terminate the ELAN membership. If the values are accepted by the LE Client, the LE Client Join phase of initialization is complete and successful.

The LE Client **MUST** obtain the values for **C23** and **C31** from the corresponding TLVs in the LE\_JOIN\_RESPONSE, if present. If either TLV is not present in the LE\_JOIN\_RESPONSE, the LE Client **MUST NOT** alter the value of the variable corresponding to the missing TLV upon receiving the LE\_JOIN\_RESPONSE.

#### 5.4.1.8 Termination of Join Procedure

If the LE\_JOIN\_RESPONSE indicates a failure, then the LE Client **MUST** terminate the ELAN membership. If the LE Client wishes to continue, it must return to the beginning of the Initialization procedure after a delay randomly selected from the interval [**C37**,**C38**].

#### 5.4.1.9 Retrying Join Request

If the LE Server does not return an LE\_JOIN\_RESPONSE within the Initial Control Time-out period, the requester **MUST** multiply the current time-out value by the time-out multiplier and retry the LE\_JOIN\_REQUEST, resetting the timer for the new time-out. This process is repeated each time the Control Time-out timer expires until the cumulative time has exceeded the maximum cumulative time-out value associated with **C7 Control Time-out**. Note that at least one retry must occur before disconnecting the Control Direct VCC. Each time the request is retried, the entire LE\_JOIN\_REQUEST frame, including the set of TLVs and excluding only the TRANSACTION-ID field **MUST** be identical to the first request. If no LE\_JOIN\_RESPONSE is obtained by the time the cumulative waiting time period exceeds the maximum cumulative time-out value (associated with **C7 Control Time-out**), then the Join phase has failed. If the requester wishes to re-attempt a LE\_JOIN\_REQUEST at this point, it **MUST** terminate its ELAN membership and it **MUST** return to the beginning of the Initialization procedure after a delay randomly selected from the interval [**C37**,**C38**].

#### 5.4.1.10 Unexpected Control Direct and Control Distribute VCC Clearing

If the LE Client detects that the Control Direct VCC or the Control Distribute VCC are released at any time other than those specified here, then the LE Client **MUST** terminate the ELAN membership. If the LE Client wishes to continue, it must return to the beginning of the Initialization procedure after a delay randomly selected from the interval [**C37**,**C38**].

#### 5.4.1.11 Ignoring LE\_JOIN\_REQUEST

An LE Client **MUST NOT** respond to an LE\_JOIN\_REQUEST.

#### 5.4.1.12 Selective Multicast Registration Mode Indicator

The LE Client **MUST** set the Selective Multicast Registration Mode Indicator flag according to the value of **C32 Selective Multicast**.

#### 5.4.1.13 Multicast Registration During Join

An LE Client **MUST NOT** register a multicast MAC address in the LE\_JOIN\_REQUEST.

## 5.4.2 Join phase - LE Server View

### 5.4.2.1 Accepting the Control Direct VCC

An LE Server SHOULD accept a UNI signalling request to establish a Control Direct VCC to any of its own ATM addresses. An LE Server MAY refuse a UNI signalling request if it contains call parameters other than as defined in Section 3.3 for non-multiplexed VCCs.

### 5.4.2.2 Waiting for LE\_JOIN\_REQUEST (S4)

If no LE\_JOIN\_REQUEST is received on a new Control Direct VCC within some period of time S4, the LE Server SHOULD terminate the Join procedure.

### 5.4.2.3 Control Distribute VCC

When the LE Server receives an LE\_JOIN\_REQUEST, it MUST decide whether the Join request is to succeed or fail. If and only if the request is to succeed, the LE Server MAY attempt to establish a Control Distribute VCC to the LE Client using the call parameters defined in Section 3.3 for LE Control Distribute. This VCC MUST be established before the LE Server can proceed with the Join phase. The LE Server MUST NOT attempt to establish a Control Distribute VCC to an LE Client after sending that LE Client an LE\_JOIN\_RESPONSE. The Control Distribute VCC to an LE Client MUST be established using the same B-LLI value as the Control Direct VCC used by that LE Client.

If an LE Server chooses to use a Control Distribute VCC to an LE Client, that Control Distribute VCC MUST be established using the LE Client's primary ATM address as the called party ATM address.

### 5.4.2.4 Validating LE\_JOIN\_REQUEST

For an LE\_JOIN\_REQUEST to succeed, the values for LAN type and maximum frame size (**C2 LAN Type** and **C3 Maximum Data Frame Size**) MUST be compatible with that of the LE Server. That is, the LAN type must either be Unspecified or MUST match the LE Server's LAN type S2 exactly, and the maximum frame size MUST either be Unspecified or must be greater than or equal to the LE Server's maximum frame size S3. If the Selective Multicast FLAGS bit is set in an LE\_JOIN\_REQUEST, then the V2 Capable FLAGS bit MUST also be set in that request. If any of these conditions are not met, the LE Server MUST reject the LE\_JOIN\_RESPONSE with a STATUS code of "Invalid request parameters."

An LE\_JOIN\_REQUEST containing a broadcast, multicast or functional MAC address as the source LAN Destination MUST be rejected with a STATUS code of "Invalid LAN Destination."

If the Preferred LES TLV is included in the LE\_JOIN\_REQUEST and the preferred LES is active, the LES MUST return a negative LE\_JOIN\_RESPONSE indicating "Invalid request parameters". If the Preferred LES TLV is included in the LE\_JOIN\_REQUEST and the preferred LES is NOT active and the LE\_JOIN\_REQUEST is valid, the LES will extract the preferred LES ATM address from the Preferred LES TLV and store the association with this LE Client in its internal tables. It MUST try and accept the LE Client. The LES MAY act as a proxy on behalf of the LE Client and verify the information it receives in the Preferred LES TLV with the LECS.

### 5.4.2.5 Duplicate Registered LAN-DESTINATION

An LE Server MUST reject any LE\_JOIN\_REQUEST if the SOURCE-LAN-DESTINATION field duplicates another LE Client's unicast LAN-DESTINATION, whether that previous registration was made via the registration protocol or via implicit registration in an LE\_JOIN\_REQUEST (STATUS code "Duplicate LAN Destination registration").

### 5.4.2.6 Duplicate ATM Address

An LE Server MUST reject an LE\_JOIN\_REQUEST if the SOURCE-ATM-ADDRESS field or Control Direct VCC Calling Party Number (which must be the same) duplicates another LE Client's ATM primary address or any other non-multiplexed ATM address registered by another LE Client (STATUS code "Duplicate ATM address").

### 5.4.2.7 Non-zero REQUESTER-LECID

An LE Server MUST reject an LE\_JOIN\_REQUEST if the REQUESTER-LECID field is not 0 (STATUS code "Invalid REQUESTER-LECID").

#### 5.4.2.8 Simplified Registration in Join

An LE Server MUST NOT store any TLVs associated with the unicast LAN Destination address from a Join request along with the LE Client's ATM address. Such TLVs can only be passed in LE\_REGISTER\_REQUEST control frames.

#### 5.4.2.9 Control Distribute VCC Failure

If the LE Client fails to accept the Control Distribute VCC connection then the LE Server MUST terminate the ELAN membership.

#### 5.4.2.10 Sending LE\_JOIN\_RESPONSE

The LE Server MAY return the LE\_JOIN\_RESPONSE to the LE Client on either the Control Direct VCC or the Control Distribute VCC (if created). If the LE Server returns an LE\_JOIN\_RESPONSE indicating a successful Join, the response MUST include C5 ELAN Name.

#### 5.4.2.11 REQUESTER-LECID

If the LE Server returns an LE\_JOIN\_RESPONSE indicating a successful join, the response MUST include a REQUESTER-LECID for the LE Client that is unique among all LE Clients joined to that same emulated LAN. The REQUESTER-LECID MUST be in the range allowed for LE Clients' LECIDs. The REQUESTER-LECID MUST be in the range X"0001" to X"FEFF" inclusive.

#### 5.4.2.12 V2 Capable LE Clients

If the V2 Capable bit is set in the FLAGS word of the LE\_JOIN\_REQUEST, then the LE Server MUST set the V2 Required FLAGS bit in a successful LE\_JOIN\_RESPONSE.

If the LE\_JOIN\_REQUEST contained the V2 Capable FLAGS bit, the LE Server MUST return the proper value of the ELAN-ID and Local Segment ID TLVs in the LE\_JOIN\_RESPONSE, according to the LE Server's variables S7 and S8.

#### 5.4.2.13 Completion of Join Phase

If the LE\_JOIN\_RESPONSE indicates a successful join, then the LE Client and LE Server have completed the Join phase of initialization.

#### 5.4.2.14 Control Distribute VCC and LE\_JOIN\_RESPONSE

The LE Server MUST NOT send an LE\_JOIN\_RESPONSE with any status other than success if it has established a Control Distribute VCC.

#### 5.4.2.15 LE Client Release

If the LE Client does not release the Control Direct VCC after the LE Server sends the LE\_JOIN\_RESPONSE indicating a failure of the Join procedure, then the LE Server SHOULD terminate the ELAN membership. The release of Control Direct VCC by the LE Client SHOULD occur within time S4 from the establishment of the Control Direct VCC to avoid this time-out.

#### 5.4.2.16 LE Server Termination

If the LE Server detects that the Control Direct VCC or the Control Distribute VCC to any given LE Client has failed, then the LE Server MUST terminate the ELAN membership of the LE Client using that VCC. If an LE Server becomes aware of the existence of another LES that is the Preferred LES of an LE Client that it is serving, then the LES MUST terminate ELAN membership of the LE Client. It MUST do this by releasing the Control Direct and Control Distribute VCCs with the UNI Reason Code "Normal, Unspecified" – Code 31.

#### 5.4.2.17 Duplicate LE\_JOIN\_REQUESTS

If the LE Server receives an LE\_JOIN\_REQUEST on a Control Direct VCC for after it has returned any LE\_JOIN\_RESPONSE on that same Control Direct VCC, and if that second LE\_JOIN\_REQUEST differs from the first in any parameter except the TRANSACTION-ID, then the LE Server MUST terminate the LE Client's ELAN membership. On receipt of a duplicate LE\_JOIN\_REQUEST (i.e. one that is identical to a previous LE\_JOIN\_REQUEST in all fields except TRANSACTION-ID, which may be different), the LE Server returns the same information it provided in response to the original LE\_JOIN\_REQUEST. This flexibility is designed to cover the case where an LE Client did not receive an LE\_JOIN\_RESPONSE.

#### 5.4.2.18 V2 Capable Bit Validation

An LE Server MUST reject any LE\_JOIN\_REQUEST if its V2 Capable FLAGS bit is clear, and either the MAXIMUM-FRAME-SIZE contains the value X"05" or an X5-Adjustment TLV is present.

## 5.4.3 Join Frames

The Join frames are used in the Join phase of LAN emulation initialization and are described in Table 25.

Table 25. Join Frame Format

Offset	Size	Name	Function
0	2	MARKER	Control Frame = X"FF00"
2	1	PROTOCOL	ATM LAN Emulation protocol = X"01"
3	1	VERSION	ATM LAN Emulation protocol version = X"01"
4	2	OP-CODE	Type of request: X"0002" LE_JOIN_REQUEST X"0102" LE_JOIN_RESPONSE
6	2	STATUS	Always X"0000" in requests. In Responses: See Table 18 for a list of values.
8	4	TRANSACTION-ID	Arbitrary value supplied by the requester and returned by the responder.
12	2	REQUESTER-LECID	Assigned LECID of joining client if join response and STATUS = "Success", else X"0000".
14	2	FLAGS	Each bit of the FLAGS field has a separate meaning if set: X"0002" V2 Capable Flag: LE Client's C29c variable is set (request only). X"0004" Selective Multicast Flag: LE Client's C32 variable is set (request only). X"0008" V2 Required Flag: New value for LE Client's C29 variable (response only). X"0080" Proxy Flag: LE Client serves non-registered MAC addresses and therefore wishes to receive LE_ARP requests for non-registered LAN Destinations. X"0200" Explorer Frames Exclude: LE Client does not wish to receive Token Ring Explorer frames.
16	8	SOURCE-LAN-DESTINATION	Optional unicast LAN Destination to register as a pair with SOURCE-ATM-ADDRESS (and no TLVs).
24	8	TARGET-LAN-DESTINATION	Always X"00" when sent, ignored on receipt.
32	20	SOURCE-ATM-ADDRESS	Primary ATM address of LE Client issuing join request.
52	1	LAN-TYPE	X"00" Unspecified X"01" Ethernet/IEEE 802.3 X"02" IEEE 802.5

53	1	MAXIMUM-FRAME-SIZE	X"00" Unspecified in Request. Illegal in Response. X"01" 1516 (non-muxed VCCs) or 1528 (LLC-muxed VCCs) Can mean 1580/1592 in Request only. See Table 21. X"02" 4544 (non-muxed VCCs) or 4556 (LLC-muxed VCCs) Can mean 1580/1592 in Request only. See Table 21. X"03" 9234 (non-muxed VCCs) or 9246 (LLC-muxed VCCs) X"04" 18190 (non-muxed VCCs) or 18202 (LLC-muxed VCCs) X"05" 1580 (non-muxed VCCs) or 1592 (LLC-muxed VCCs)
54	1	NUMBER-TLVs	Number of Type/Length/Value elements encoded in Request/Response.
55	1	ELAN-NAME-SIZE	Number of octets in ELAN-NAME. X"00" indicates empty ELAN-NAME.
56	20	TARGET-ATM-ADDRESS	Always X"00" when sent, ignored on receipt.
76	32	ELAN-NAME	Name of emulated LAN. Expresses LE Client's preference in LE_JOIN_REQUEST, specifies name of LAN joined in successful LE_JOIN_RESPONSE, else not used. Format is SNMPv2 DisplayString.
108	var	TLVs	

#### 5.4.4 Join Request Supported TLVs

The following table describes the TLV encodings of further operational parameters supplied by an LE Client in an LE\_JOIN\_REQUEST.

Table 26. Join Request Frame - Supported TLVs

Item	Version
Layer-3-Address	LANE v2
X5-Adjustment	LANE v2
Preferred-LES	LANE v2

#### 5.4.5 Join Response - Supported TLVs

The following table describes the TLV encodings of further operational parameters supplied by an LE Server in an LE\_JOIN\_RESPONSE.



Table 27. Join Response Frame - Supported TLVs

Item	Version
ELAN-ID	LANE v2
Local-Segment-ID	LANE v2

## 5.5 Registration During Initialization

After completing the Join phase, an LE Client MAY attempt to register additional LAN Destinations from its **C6 Local Unicast MAC Address(es)**, **C8 Local Route Descriptor(s)** and **C15** variables according to the procedures described in Section 6, Registration. Registration at this time is provided so that an LE Client can register those LAN Destinations which are required for its normal operation. An LE Client MAY (but is not required to) terminate all connections and restart Initialization if it fails to register any LAN Destinations at this time, without ever becoming operational.

## 5.6 Connecting to the BUS Protocol and Procedures

The Protocol and Procedures for an LE Client connecting to the BUS follows.

### 5.6.1 Protocol

#### 5.6.1.1 Connecting to the BUS - LE Client View

##### 5.6.1.1.1 Determining BUS ATM Address

An LE Client MUST connect to the BUS. The address of the BUS is determined by using the address resolution procedure (LE\_ARP\_REQUEST) to resolve the all ones (X"FFFFFFFFFFFF") broadcast MAC address. The LE Service will respond to the LE\_ARP\_REQUEST with an LE\_ARP\_RESPONSE containing the BUS ATM address (**S6**). If the address resolution procedure fails, the LE\_Client must terminate its membership in the ELAN. If the LE\_Client wishes to continue, it must return to the beginning of the Initialization procedure after a delay randomly selected from the interval [**C37**,**C38**].

##### 5.6.1.1.2 Default Multicast Send VCCs

The LE Client MUST establish the Default Multicast Send VCC to the BUS, and the calling party ATM address for this connection MUST be the LE Client's primary ATM address, as defined in Section 5.1.1. The Multicast Send VCC MUST be signalled using the call parameters defined in Section 3.3 for the LAN Emulation Ethernet/IEEE 802.3 Multicast Send VCC or the LAN Emulation IEEE 802.5 Multicast Send VCC, as appropriate. All multicast destination frames not sent over a Selective Multicast Send VCC MUST be transmitted to the BUS over this VCC.

##### 5.6.1.1.3 LE Client Accepts Multicast Forward VCC

In order to receive traffic sent to a multicast address on an emulated LAN, a client must first have a connection from the BUS. The act of opening the Default Multicast Send VCC to the BUS ATM address described above will automatically cause the BUS to connect back to the client to establish one or more Multicast Forward VCCs. These connections will be point-to-multipoint connections.

The LE Client MUST accept all such connections to receive all of the broadcast and multicast frames (and potentially, unknown unicast frames) on the emulated LAN. The calling party identifier of the connection setup for a Multicast Forward VCC may or may not contain the ATM address which was returned to the client when it got the LE\_ARP\_RESPONSE described above. The LE Client MAY request validation of this ATM Address using the LE\_VERIFY protocol described in Section 9. The called party identifier will contain the ATM address which the LE Client used as the calling party identifier when it opened the Default Multicast Send VCC. The call parameters signalled by the BUS are those defined in Section 3.3 for Multicast Forward VCCs.

##### 5.6.1.1.4 Losing BUS Connections

If the LE Client detects release of the Default Multicast Send VCC for any reason, it MAY release all of its Multicast Forward VCCs (UNI Reason Code "normal, Unspecified" - Cause 31). The LE Client MAY re-attempt connection to the BUS by re-executing the procedures of Section 5.6.1.1 up to **C39** times. If, after re-discovering the

BUSs ATM Address, the new ATM Address is different from the previous one, the LE Client MUST release all of its Multicast Forward VCCs (UNI Reason Code "normal, Unspecified" - Cause 31) if not already released.

If the LE Client is unable (or unwilling) to regain its connection to the BUS, it MUST terminate its ELAN membership and return to the Initialization phase after a delay randomly selected from the interval [C37, C38].

#### **5.6.1.1.5 Loss of Selective Multicast Send VCC**

If the LE Client detects the release of a Selective Multicast Send VCC for any reason, it need take no immediate action other than those specified in Section 7. If the LE Client wishes to re-establish a Selective Multicast Send VCC, for example, because it has (or expects to have) more data to transmit to the corresponding multicast MAC address(es), then it MUST issue an LE\_ARP\_REQUEST for each multicast MAC address it wishes to transmit.

#### **5.6.1.1.6 Loss of Multicast Forward VCC, Not the Last**

If the LE Client detects the release of a Multicast Forward VCC for any reason, and that LE Client still has at least one Multicast Forward VCC established or being signalled, then the LE Client MUST NOT attempt any recovery process for the VCC.

#### **5.6.1.1.7 Loss of the Last Multicast Forward VCC**

If the LE Client detects the release of a Multicast Forward VCC for any reason, and that LE Client has no Multicast Forward VCCs established or being signalled, then the LE Client is disconnected from the BUS. If this condition persists longer than time C33, the LE Client MUST release its Default Multicast Send VCC. The LE Client MAY re-attempt connection to the BUS by re-executing the procedures of Section 5.6.1.1 up to C39 times.

If the LE Client is unable (or unwilling) to regain its connection to the BUS, it MUST terminate its ELAN membership and return to the Initialization phase after a delay randomly selected from the interval [C37, C38].

#### **5.6.1.1.8 Unexpected Control Direct and Control Distribute VCC Clearing**

If the LE Client detects that the Control Direct VCC or the Control Distribute VCC are released then the LE Client MUST terminate the ELAN membership. If the LE Client wishes to continue, it must return to the beginning of the Initialization procedure after a delay randomly selected from the interval [C37,C38].

#### **5.6.1.1.9 Releasing Multicast Forward VCCs**

An LE Client MUST NOT release a Multicast Forward VCC except as specified in the above sections.

### **5.6.1.2 Connecting to the BUS - BUS View**

#### **5.6.1.2.1 BUS Opens Multicast Forward VCC**

When an LE Client successfully joins an emulated LAN and after the client successfully establishes a bi-directional Default Multicast Send VCC to the BUS (see above), the BUS MUST attempt to open at least one Multicast Forward VCC back to the client.

This MUST be performed by adding the client as a leaf to a point-to-multipoint VCC.

#### **5.6.1.2.2 Called Party Number Provided**

The calling party number which was used by the LE Client to signal the Multicast Send VCC MUST be used by the BUS as the called party number (ATM address) for the Multicast Forward VCC.

#### **5.6.1.2.3 B-LLI Codepoint**

The call parameters signalled by the BUS MUST be those defined in Section 3.3 for Multicast Forward VCCs.

#### **5.6.1.2.4 BUS Action on Release of Default Multicast Send VCC**

If the BUS detects an LE Client has no Default Multicast Send VCC to the BUS, and this condition persists for more than time S9, the LE Service MAY terminate that LE Client.

#### **5.6.1.2.5 BUS Action on Release of Multicast Forward VCC**

If the BUS detects that an LE Client's Multicast Forward VCC has been released for any reason, and that LE Client still has at least one Default Multicast Send VCC to the BUS, then the BUS SHOULD attempt to re-establish the Multicast Forward VCC to the LE Client. The BUS MUST NOT attempt to re-establish any Multicast Forward VCCs as long as it has no Default Multicast Send to the LE Client.

#### **5.6.1.2.6 Failure to Establish Multicast Forward VCC**

If the BUS is unable to set up a Multicast Forward VCC, the LE Service MAY terminate that LE Client.

## 6. Registration Protocol, Procedures and Frame Formats

Registration is the procedure whereby the LE Client establishes with the LE Server any additional (LAN Destination, ATM Address) pairs not registered in the Join procedure. Registration and Unregistration of LAN Destinations may occur at any time after successfully joining an emulated LAN.

Registration protocol frames are of four types:

- LE\_REGISTER\_REQUEST**: Sent by the LE Client to the LE Server. Requests that the LE Server register one LAN Destination - ATM address pair for the LE Client. In addition, the LE Client may use these procedures to associate TLV information with a LAN Destination.
- LE\_REGISTER\_RESPONSE**: Sent by the LE Server to the LE Client in response to an LE\_REGISTER\_REQUEST frame. Confirms or denies the registration request.
- LE\_UNREGISTER\_REQUEST**: Sent by the LE Client to the LE Server. Requests that the LE Server remove the registration of one LAN Destination - ATM address pair and associated TLV information for the LE Client.
- LE\_UNREGISTER\_RESPONSE**: Sent by the LE Server to the LE Client in response to an LE\_UNREGISTER\_REQUEST frame. Confirms or denies the unregistration request.

These frame formats are described in Section 6.2.

In the following sections describing registration, the terms “accept” and “deny” are used with regard to LE\_REGISTER\_REQUEST. The LE Server “accepts” an LE\_REGISTER\_REQUEST by returning a successful LE\_REGISTER\_RESPONSE, and “denies” it by returning a failure code in the LE\_REGISTER\_RESPONSE.

If an LE Client sends an LE\_REGISTER\_REQUEST with TLVs, and the LES does not have an existing entry for the specified MAC-ATM binding, it must register the new MAC-ATM-TLVs binding in its address table. However, if there is an existing MAC-ATM binding in the LES, upon receiving a new register request for that binding, the LES replaces any associated TLVs with the new set of TLVs (even if that new set is empty).

An LE Client with only one unicast LAN Destination need not use the registration protocol, since every LE Client may implicitly register one unicast LAN Destination during the join phase. A Join with a unicast LAN Destination is functionally equivalent to a Join without a LAN Destination, followed by a Register with a LAN Destination and no TLVs. If TLVs are included in the Register, then the two procedures are not functionally equivalent. Only TLVs included in a Register request are associated with the source LAN Destination.

An LE Client may register unicast MAC addresses, LAN Destinations, and if it is using the Selective Multicast facility, multicast MAC addresses, with the LE Service.

### 6.1 Registration Procedures

#### 6.1.1 Registration - LE Client View

##### 6.1.1.1 Registration Protocol VCC

Registration protocol frames MUST only be sent by an LE Client over the Control Direct VCC.

##### 6.1.1.2 Unicast Registration Requirements

All LE Clients MUST register all of their local unicast LAN Destinations (**C6 Local Unicast MAC Address(es)**). In addition, all LE Clients on a Token Ring emulated LAN MUST register all of their Local Route Descriptors, (**C8 Local Route Descriptor(s)**). Once an LE Client has reached the operational state, it MUST NOT have in its variables **C6 Local Unicast MAC Address(es)** or **C8 Local Route Descriptor(s)** any LAN Destination which has not successfully been registered with the LE Server. If an LE Client is unsuccessful registering one or more of the LAN Destinations in **C6 Local Unicast MAC Address(es)** or **C8 Local Route Descriptor(s)**, the LE Client must terminate its ELAN membership. If the LE Client wishes to continue, it must return to the beginning of the

Initialization procedure after a delay randomly selected from the interval [C37,C38]. An exception is an LE Client which joined the emulated LAN as a proxy (C4 Proxy is set) and the registration failed with status code 6 ("Insufficient resources to grant request"). In this case the LE Client MAY continue after moving the LAN Destination from C6 Local Unicast MAC Address(es) to C27 or C8 Local Route Descriptor(s) to C30 without terminating its ELAN membership. LE Clients MUST NOT register non-local LAN Destinations (C27 or C30). LE Clients MAY include TLVs in any LE\_REGISTER\_REQUEST.

#### 6.1.1.3 Multicast Registration Requirements

An LE Client, whose C29 V2 Capable and C32 Selective Multicast variables are both set, MUST register all of its multicast MAC addresses C15, except for the broadcast address. Once such an LE Client has reached the operational state, it MUST NOT have in its variable C15 any MAC address (other than the broadcast address) which has not successfully been registered with the LE Server.

#### 6.1.1.4 Ignoring Registration Protocol Frames

An LE Client MUST ignore any registration protocol frames received over any VCC other than the Control Direct VCC or the Control Distribute VCC.

#### 6.1.1.5 Registering the Broadcast Address

An LE Client MUST NOT register for the broadcast address.

#### 6.1.1.6 Duplicate LE\_REGISTER\_REQUEST or LE\_UNREGISTER\_REQUESTs

If the LE Server does not return an LE\_REGISTER\_RESPONSE (LE\_UNREGISTER\_RESPONSE) within the Initial Control Time-out period, the requester MUST multiply the current time-out value by the time-out multiplier and retry the LE\_REGISTER\_REQUEST (LE\_UNREGISTER\_REQUEST), resetting the timer for the new time-out. This process is repeated each time the Control Time-out timer expires until the cumulative time has exceeded the maximum cumulative time-out value associated with C7 Control Time-out. Note that at least one retry must occur. Each time the request is retried, all fields - except for the TRANSACTION-ID field - MUST be identical to the same field in the first request. TLVs MUST also be the same for retries. If no response is obtained by the time the cumulative waiting time period exceeds the maximum cumulative time-out value (associated with C7 Control Time-out), then the register (unregister) has failed. If the requester wishes to continue at this point, it MUST terminate its ELAN membership and it MUST return to the beginning of the Initialization procedure after a delay randomly selected from the interval [C37,C38].

#### 6.1.1.7 Duplicate Registration Frame Frequency

An LE Client MUST NOT repeat an LE\_REGISTER\_REQUEST or LE\_UNREGISTER\_REQUEST for the same MAC address or Route Descriptor more often than once per second.

#### 6.1.1.8 Optional Termination

If an LE Client is unable to obtain a registration response from the LE Server after some number of attempts to register or unregister a LAN Destination, it MAY terminate the ELAN membership.

#### 6.1.1.9 Ignoring Request Frames

An LE Client MUST NOT respond to an LE\_REGISTER\_REQUEST or an LE\_UNREGISTER\_REQUEST.

#### 6.1.1.10 LLC-Multiplexed and Non-Multiplexed ATM Addresses

An LE Client MAY register a non-multiplexed ATM address, an LLC-multiplexed ATM address, or both, in an LE\_REGISTER\_REQUEST for a Route Descriptor or a unicast MAC address. A non-multiplexed ATM address (in the SOURCE-ATM-ADDRESS field) MUST be unique to the LE Client.

An LE Client MUST NOT register an LLC-multiplexed ATM address in an LE\_REGISTER\_REQUEST for a multicast MAC address. An LE Client MUST include its primary ATM address as the non-multiplexed ATM Address in an LE\_REGISTER\_REQUEST for a multicast MAC address.

#### 6.1.1.11 Unexpected Control Direct and Control Distribute VCC Clearing

If the LE Client detects that the Control Direct VCC or the Control Distribute VCC are released then the LE Client MUST terminate the ELAN membership. If the LE Client wishes to continue, it must return to the beginning of the Initialization procedure after a delay randomly selected from the interval [C37,C38].

### 6.1.1.12 Source ATM Address in LE\_REGISTER\_REQUEST

An LE Client MUST place only an ATM address from its variable C1n in the SOURCE-ATM-ADDRESS field of an LE\_REGISTER\_REQUEST. If the LE Client includes the LLC-Muxed-ATM -Address TLV in the LE\_REGISTER\_REQUEST, it MUST use in that TLV only an ATM address from its variable C1m.

## 6.1.2 Registration - LE Server View

### 6.1.2.1 Registration Frames

An LE Server MUST send all registration protocol frames over the Control Direct VCC or the Control Distribute VCC (if it exists) to an LE Client. If either of an LE Client's C29 or C32 variables is clear, then that LE Client MUST NOT register a multicast group MAC address or functional address.

### 6.1.2.2 Ignoring Registration Frames

An LE Server MUST ignore all registration protocol frames received over any VCC other than a Control Direct VCC.

### 6.1.2.3 Multiple Unicast MAC Registrations

An LE Server MUST NOT allow two or more different LE Clients to register the same Route Descriptor or unicast MAC address.

### 6.1.2.4 Multiple Multicast MAC Registrations

An LE Server MUST allow any number of different LE Clients to register the same multicast MAC address.

### 6.1.2.5 Multiple ATM Registrations

An LE Server MUST deny an LE\_REGISTER\_REQUEST with the STATUS code "Duplicate ATM Address" which attempts to register a non-multiplexed ATM address which matches a non-multiplexed ATM address registered by any other LE Client in the same ELAN. Similarly, an LE Server MUST deny an LE\_REGISTER\_REQUEST with the STATUS code "Duplicate ATM Address" which attempts to register an LLC-multiplexed ATM address which matches an LLC-multiplexed ATM address registered by any other LE Client in the same ELAN. An LE Server MUST NOT deny an LE Client to register an LLC-multiplexed ATM address merely because it matches a non-multiplexed address already registered by another client in the same ELAN. Similarly, an LE Server MUST NOT deny an LE Client to register a non-multiplexed ATM address merely because it matches an LLC-multiplexed address already registered by another client in the same ELAN.

### 6.1.2.6 One Registered ATM address per LAN Destination

An LE Server MUST NOT allow an LE Client to register more than one LLC-multiplexed ATM address, or more than one non-multiplexed ATM address, for any given LAN Destination. An LE Server MUST allow (but not require) an LE Client to register both an LLC-multiplexed and a non-multiplexed ATM address for any given unicast LAN Destination.

### 6.1.2.7 Denying LE\_REGISTER\_REQUEST

An LE Server MUST deny an LE\_REGISTER\_REQUEST with the STATUS code "Invalid LAN Destination" for the broadcast address. An LE Server MUST deny an LE\_REGISTER\_REQUEST with the STATUS code "Invalid LAN Destination" for a multicast MAC address, if the LE Client attempting the registration did not include the V2 Capable and Selective Multicast FLAGS bits in its LE\_JOIN\_REQUEST.

An LE Server MUST deny an LE\_REGISTER\_REQUEST with the STATUS code "Invalid LAN Destination" for a multicast address which includes the LLC-Muxed-ATM-Address TLV. An LE Server MUST deny an LE\_REGISTER\_REQUEST with the STATUS code "Invalid LAN Destination" for a multicast address where the SOURCE-ATM-ADDRESS is different from the LE Client's primary ATM address.

### 6.1.2.8 Registered TLVs

If an LE Server receives a valid LE\_REGISTER\_REQUEST with zero or more TLVs, it must register those TLV(s) along with the {LAN Destination, ATM address} pair. The TLVs or their absence in a valid LE\_REGISTER\_REQUEST replaces the previously stored TLV information for that {LAN Destination, ATM address} pair.

### 6.1.2.9 Duplicate LE\_REGISTER\_REQUESTs for Same LE Client

An LE Server MUST positively acknowledge an otherwise valid LE\_REGISTER\_REQUEST for a (LAN Destination, LLC-multiplexed ATM address) or (LAN Destination, non-multiplexed ATM address) pair that duplicates a pair already registered by that same LE Client. The set of TLVs included in a duplicate LE\_REGISTER\_REQUEST overwrites the set of TLVs currently associated with a MAC-ATM binding, even if the new set of TLVs is empty.

### 6.1.2.10 LE\_UNREGISTER\_REQUEST for Unregistered LAN Destination

An LE Server MUST return a successful response to an otherwise valid LE\_UNREGISTER\_REQUEST for a LAN Destination the requester had not registered. It MUST NOT, however, actually unregister a LAN Destination registered by another client.

### 6.1.2.11 First Registration Wins

If an LE\_REGISTER\_REQUEST (or implicit registration in an LE\_JOIN\_REQUEST) conflicts with a previous registration, thus violating the above restrictions on multiple registration of a LAN Destination or ATM Address, then the LE\_REGISTER\_RESPONSE MUST indicate a failure (STATUS code "Duplicate LAN Destination registration" or "Duplicate ATM Address").

### 6.1.2.12 Matching Register and Unregister Requests

An LE\_UNREGISTER\_REQUEST MUST match the REQUESTOR-LECID and LAN-DESTINATION fields to unregister the previous registration. As the result of a successful match, the LE Server MUST delete all bindings to ATM address(es) and TLVs.

## 6.2 Registration Frames

Table 28 describes Registration frames, which are used to register MAC addresses and Route Descriptors with the LE Server.

Table 28. Registration Frame Format

Offset	Size	Name	Function
0	2	MARKER	Control Frame = X"FF00"
2	1	PROTOCOL	ATM LAN Emulation protocol = X"01"
3	1	VERSION	ATM LAN Emulation protocol version = X"01"
4	2	OP-CODE	Type of request: X"0004" LE_REGISTER_REQUEST X"0104" LE_REGISTER_RESPONSE X"0105" LE_UNREGISTER_RESPONSE X"0105" LE_UNREGISTER_RESPONSE
6	2	STATUS	Always X"0000" in requests. In Responses: See Table 18 for a list of values.
8	4	TRANSACTION-ID	Arbitrary value supplied by the requester.
12	2	REQUESTER-LECID	LECID of LE Client issuing the LE_REGISTER_REQUEST or LE_UNREGISTER_REQUEST and returned by the responder.
14	2	FLAGS	Always X"00" when sent, ignored on receipt.
16	8	SOURCE-LAN-DESTINATION	MAC address or Route Descriptor LE Client is attempting to register.
24	8	TARGET-LAN-DESTINATION	Always X"00" when sent, ignored on receipt.
32	20	SOURCE-ATM-ADDRESS	A non-multiplexed ATM address of LE Client issuing the register or unregister request.
52	2	RESERVED	Always X"00" when sent, ignored on receipt.
54	1	NUMBER-TLVS	Number of Type/Length/Value elements encoded in Request/Response.
55	53	RESERVED	Always X"00" when sent, ignored on receipt.
108	Var	TLVs	

### 6.2.1 Register Request Frame - Supported TLVs

The following table lists the TLVs which are supported by the LE\_REGISTER\_REQUEST message. See Annex A for Parameter Encodings.

Table 29. Register Request Frame - Supported TLVs

Item	Version
LLC-Muxed-ATM-Address	LANE v2
Service-Category	LANE v2
User Defined TLVs	LANE v2



## 7. Address Resolution Protocol, Procedures and Frame Formats

The basic flow of the address resolution protocol and Data Direct VCC management has been described in Section 2. There are four types of frames associated with address resolution protocol:

- **LE\_ARP\_REQUEST:** Sent by an LE Client to determine the ATM address associated with a given MAC address or Route Descriptor.
- **LE\_ARP\_RESPONSE:** Sent by the LE Server or an LE Client in response to an LE\_ARP\_REQUEST to provide the information requested.
- **LE\_NARP\_REQUEST:** Sent by an LE Client to advertise changes in Remote address bindings.
- **LE\_TOPOLOGY\_REQUEST:** Sent by LE Client or LE Server to indicate whether network topology change is in progress.

These frame formats are described in Table 30, Table 32 and Table 34. The specific procedures for address resolution and VCC connection management are presented in separate sections, one for LE Clients, and one for the LE Server.

If an LE Client includes a source LAN Destination in its LE\_ARP request, it must include the set of TLVs that would be returned to an LE Client LE\_ARPing for that LAN Destination. A LES or proxy LEC responding to an LE\_ARP request may include a set of TLVs in the LE\_ARP response. LE Clients learning MAC-ATM bindings via LE\_ARP also learn the TLVs associated with a particular LAN Destination.

### 7.1 Address Resolution - LE Client View

#### 7.1.1 Address Resolution Over Control Direct VCC

An LE Client **MUST** send all LE\_ARP\_REQUESTs, LE\_ARP\_RESPONSEs, LE\_NARP\_REQUESTs and LE\_TOPOLOGY\_REQUESTs over the Control Direct VCC.

#### 7.1.2 Accepting Address Resolution Frames

An LE Client **MUST** accept LE\_ARP\_REQUESTs, LE\_ARP\_RESPONSEs, LE\_NARP\_REQUESTs and LE\_TOPOLOGY\_REQUESTs arriving on either the Control Direct VCC or the Control Distribute VCC (if any).

#### 7.1.3 Ignoring Frames Prior to Joining

An LE Client **MUST NOT** respond to any LE\_ARP\_REQUEST if it has not completed the Join procedure regardless of the other provisions in Section 7.1.

#### 7.1.4 Sending LE\_ARP\_REQUESTs for Multicast MAC Addresses

An operational LE Client **MUST** send an LE\_ARP\_REQUEST for any multicast LAN Destination when **C29** (V2 Capable) is set.

#### 7.1.5 Responding to LE\_ARP\_REQUESTs for LAN Destinations

An operational LE Client **MUST** respond to any LE\_ARP\_REQUEST it receives that requests information for any LAN Destination in that client's variables **C6 Local Unicast MAC Addresses**, **C8 Local Route Descriptors**, **C27 Remote Unicast MAC Addresses**, and **C30 Remote Route Descriptors**. It **MUST NOT** respond to any LE\_ARP\_REQUEST for a LAN Destination not in those four variables. The LE Client **MAY** return TLVs in any LE\_ARP\_RESPONSE.

### 7.1.6 Local LAN Destinations

An LE Client **MUST** clear the Remote Address FLAGS bit in any LE\_ARP\_RESPONSE sent for a unicast LAN Destination in that Client's variables **C6 Local Unicast MAC Addresses** or **C8 Local Route Descriptors**.

### 7.1.7 Remote LAN Destinations

An LE Client **MUST** set the Remote Address FLAGS bit in any LE\_ARP\_REQUEST or LE\_ARP\_RESPONSE advertising for a unicast LAN Destination in that Client's variables **C27 Remote Unicast MAC Addresses** or **C30 Remote Route Descriptors**.

If a LAN-attached endsystem is moved from one proxy agent to another, it is possible for a period of time that both proxy LE Clients will reply to an LE\_ARP\_REQUEST for the same LAN-attached endsystem.

### 7.1.8 LLC-Multiplexed and Non-Multiplexed ATM Addresses

An LE Client **MUST** place only an ATM address from its variable **C1n** in the SOURCE-ATM-ADDRESS field of an LE\_ARP\_REQUEST or the TARGET-ATM-ADDRESS field of an LE\_ARP\_RESPONSE. If the LE Client includes the LLC-Muxed-ATM-Address TLV in the LE\_ARP response, it **MUST** use only an ATM address from its variable **C1m** in that TLV.

### 7.1.9 Choice of ATM Address in LE\_ARP\_REQUEST

When sending LE\_ARP\_REQUEST with an ATM address in the SOURCE-ATM-ADDRESS field, an LE Client **MUST** supply an ATM address that is unique to that LE Client.

### 7.1.10 Choice of ATM Address in LE\_ARP\_RESPONSE

When responding to an LE\_ARP\_REQUEST with an ATM address in the TARGET-ATM-ADDRESS field, an LE Client **MUST** respond with an ATM address that is unique to that LE Client.

### 7.1.11 Service-Category TLV

An LE Client wishing to advertise that it supports service categories other than UBR **SHOULD** include the Service-Category TLV in all LE\_REGISTER\_REQUESTs and LE\_ARP\_RESPONSEs for LAN Destinations for which it wants to advertise this capability.

### 7.1.12 Obtaining BUS ATM Address for Broadcasts and Unknown LAN Destinations

An LE Client **MUST** obtain the address of the Broadcast and Unknown Server by sending an LE\_ARP\_REQUEST for the broadcast group address.

### 7.1.13 Transmitting to Unresolved LAN Destination

For each **C10 Maximum Unknown Frame Count** data frames for the same unresolved unicast or multicast LAN Destination sent by an LE Client to the BUS within a time period **C11 Maximum Unknown Frame Time** seconds, that LE Client **MUST** send at least one LE\_ARP\_REQUEST to the LE Server to resolve that LAN Destination.

### 7.1.14 Establishing Connections

Upon receiving an LE\_ARP\_RESPONSE containing an ATM address for which it has an unresolved LE-ARP cache entry pending and no existing Data Direct VCC, an LE Client **MUST** either issue a connection SETUP for a direct VCC to that address if its available resources permit, or else a connection RELEASE to some other VCC to free up the resources to make that connection.

### 7.1.15 B-LLI Code Points

In the SETUP for a Data Direct VCC, an LE Client **MUST** use the B-LLI code point for an Ethernet/IEEE 802.3 LE Data Direct VCC or IEEE 802.5 LE Data Direct VCC if LE Client chooses to use the TARGET-ATM-ADDRESS from the LE\_ARP\_RESPONSE, and **MUST** use the B-LLI code point for an LLC-multiplexed VCC if using the LLC-Muxed-ATM-Address TLV. In the SETUP for a Multicast Send VCC, an LE Client **MUST** use the B-LLI

code point for an Ethernet/IEEE 802.3 LE Multicast Send/Forward VCC or IEEE 802.5 LE Multicast Send/Forward VCC.

#### 7.1.16 LE\_ARP\_REQUEST Frequency

An LE Client MUST NOT transmit an LE\_ARP\_REQUEST for the same LAN Destination more often than once every second.

#### 7.1.17 LE\_ARP Cache (C16)

An LE Client MUST cache in C16 the LAN Destination / ATM Address mapping information received in at least those LE\_ARP\_RESPONSEs corresponding to LE\_ARP\_REQUESTs sent by that LE Client. The set of TLVs returned in any such LE\_ARP\_RESPONSE MUST be associated with the TARGET-LAN-DESTINATION in the requester's LE\_ARP cache. An LE Client MAY also incorporate information from any other LE\_ARP\_REQUEST or LE\_ARP\_RESPONSE it receives, including those not directed to that LE Client, into its C16 LE\_ARP Cache.

#### 7.1.18 Verifying LE\_ARP Cache Entries

An LE Client MUST attempt to verify a unicast LAN Destination entry in its LE\_ARP cache before deleting it due to a time out. An LE Client MAY verify an entry in its LE\_ARP cache (C16) by one or more of the following methods: by receiving an LE\_ARP\_RESPONSE or LE\_NARP\_REQUEST that applies to the entry; by learning the unicast MAC source address and/or Routing Information Field from an incoming data frame on a Data Direct VCC. An LE Client that reverifies an entry based on a LE\_ARP or LE\_NARP control frame MUST associate the set of TLVs in that frame with the reverified response, overwriting any existing associated TLVs. An LE Client that reverifies an entry based on learning via a Data Direct VCC MUST NOT alter the set of TLVs associated with the reverified LE\_ARP cache entry. Verification procedures MUST not be applied to multicast MAC addresses in the LE\_ARP cache.

#### 7.1.19 Elimination of LE\_ARP Cache Entries

In order to avoid unnecessary LE\_ARP activity, an LE Client SHOULD remove any unicast or multicast LE\_ARP cache entry which has not been used to forward a data frame for a long period of time, whether or not that entry has been recently verified.

#### 7.1.20 Aging Time

While connected to the LES, an LE Client MUST NOT use any entry in its LE\_ARP cache (C16) for a Route Descriptor or unicast MAC address after the Aging Time (C17) has elapsed since the last verification of that entry. (Creation of an LE\_ARP cache entry via LE\_ARP is a form of verification.). An LE Client MUST NOT age multicast LAN Destinations in the LE\_ARP cache. If a LE Client is in a state of having lost connectivity to its LES but has not yet rejoined, it MAY continue to use LE\_ARP cache entries until it is able to perform the usual re-verification procedures.

#### 7.1.21 LE\_ARP\_REQUEST Maximum Retries

If an LE Client issues an LE\_ARP\_REQUEST for an LE\_ARP Cache entry that is soon to expire, it MUST NOT issue more than C13 LE\_ARP\_REQUESTs before the entry expires.

#### 7.1.22 Removing Multicast Entries from LE\_ARP Cache

If a Multicast Send VCC is lost for any reason, then all multicast entries in C16 LE\_ARP Cache which are associated with the remote ATM address of that VCC must be purged.

#### 7.1.23 Topology Change Flag (C19)

An LE Client whose Topology Change flag (C19) is set SHOULD NOT use any non-local entry in its LE\_ARP cache C16 for a unicast MAC address after the Forward Delay Time C18 has elapsed since the last verification of that entry.

### 7.1.24 Updating Topology Change Flag (C19)

Whenever an LE Client receives an LE\_TOPOLOGY\_REQUEST frame from the LE Server with the Topology Change bit set in its FLAG field, the LE Client MUST set **C19 Topology Change** flag. An LE Client MUST clear **C19 Topology Change** flag whenever it receives an LE\_TOPOLOGY\_REQUEST frame from the LE Server whose FLAG field has the Topology Change bit clear.

### 7.1.25 Generation of LE\_TOPOLOGY\_REQUESTS

An LE Client that is acting as an IEEE 802.1D transparent bridge MUST send one LE\_TOPOLOGY\_REQUEST to its LE Server for every Configuration BPDU it sends to the BUS. The Topology Change bit in the FLAGS field in the LE\_TOPOLOGY\_REQUEST MUST be set to the same value as the Topology Change bit in the Configuration BPDU.

### 7.1.26 Local Management Directives

A LE Client MAY send LE\_TOPOLOGY\_REQUESTs to its LE Server in response to local management directives or network management directives. However, such LE\_TOPOLOGY\_REQUESTs MAY be sent while bridge clients are still active, and MAY have either value for the Topology Change bit. Note that adverse operation may result in all LE Clients when more than one LE Client generates LE\_TOPOLOGY\_REQUESTs and the topology change status values do not agree.

### 7.1.27 Spanning Tree Configuration BPDUs

An LE Client that is acting as an IEEE 802.1D bridge MAY choose to base its LAN Emulation Topology Change state on Spanning Tree configuration BPDUs, rather than on received LE\_TOPOLOGY\_REQUESTs. This rule<sup>21</sup> applies only to IEEE 802.1D bridge clients and takes priority over rules 7.1.23 and 7.1.24.

### 7.1.28 Unresolved LE\_ARP\_REQUESTs

An LE Client MUST NOT retry an LE\_ARP\_REQUEST for a given frame's unicast or multicast LAN Destination more than **C13** times after the first LE\_ARP\_REQUEST for that same frame's unicast or multicast LAN Destination. By the time the last-allowed LE\_ARP\_REQUEST has timed out the LE Client SHOULD have transmitted the frame to the BUS. This does not preclude sending that frame to the BUS before the failure of the address resolution protocol. However, if this transmission would violate the restrictions imposed by the **C10 Maximum Unknown Frame Count** and **C11 Maximum Unknown Frame Time**, the data frame MUST be discarded.

### 7.1.29 Version 1 LE\_NARP\_REQUEST

An LE Client MAY generate an unsolicited LE\_NARP\_REQUEST to allow other clients to learn about a changed Remote LAN-ATM address binding. This LE\_NARP\_REQUEST advertises that the generating LE Client believes that an old binding between TARGET-LAN-DESTINATION and TARGET-ATM-ADDRESS is no longer valid, and that the generating LE Client now serves the LAN destination. An LE Client receiving a valid LE\_NARP\_REQUEST MAY delete any of its LE\_ARP cache entries that match the TARGET-LAN-DESTINATION and TARGET-ATM-ADDRESS, and MAY replace such entries with the binding between TARGET-LAN-DESTINATION and SOURCE-ATM-ADDRESS. The generating LE Client MUST include the ATM address of the LE Client which was previously representing the LAN destination. The LLC-Muxed ATM Address TLV MUST NOT be included in a LANE v1 LE\_NARP\_REQUEST.

---

<sup>21</sup>The reason for this rule is as follows. An LE Client that is acting as an IEEE 802.1D bridge might maintain a combined bridge forwarding database and LE\_ARP cache, aging out MAC addresses as appropriate for the Spanning Tree Protocol. At best, received LE\_TOPOLOGY\_REQUESTs will duplicate information which should be available in configuration BPDUs. At worst, they might tell the bridge to change aging times in some way that is inconsistent with the Spanning Tree protocol. For instance, a network manager might try to clear the Topology Change mode while the IEEE 802.1D bridge client is still participating in the emulated LAN. To allow the implementation of combined bridge forwarding databases and LE\_ARP caches without requiring bridge clients to violate the IEEE 802.1D bridging specification, it is necessary to give Spanning Tree precedence in the event of such conflicts.

Note that the function of the version 1 LE\_NARP\_REQUEST has been superseded by the targetless LE\_ARP\_REQUEST (see section 7.1.30) and the no-source LE\_NARP\_REQUEST (see section **Error! Reference source not found.**) so a V2 LE Client connected to a V2 LE Server SHOULD never generate a LANE v1 LE\_NARP\_REQUEST if the LE Client is operational and C29 is set.

### 7.1.30 Targetless LE\_ARP\_REQUEST

An LE Client MAY generate an LE\_ARP\_REQUEST with the TARGET-LAN-DESTINATION field indicating "not present", but with the SOURCE-LAN-DESTINATION, SOURCE-ATM-ADDRESS, and optionally, the LLC-Muxed-ATM-Address TLV present.

This allows the generating LE Client to advertise an LE\_ARP cache binding to all other LE Clients in its ELAN. An LE Client receiving a targetless LE\_ARP\_REQUEST MUST delete any LE\_ARP cache bindings to that SOURCE-LAN-DESTINATION, and MAY replace any such bindings with the information from the LE\_ARP\_REQUEST.

If an LE Client sends out a targetless LE\_ARP\_REQUEST for a currently registered unicast LAN Destination, it must have the same bindings and TLVs as the most recent LE\_REGISTER\_REQUEST for that LAN Destination sent to the LE Server.

An LE Client receiving a targetless LE\_ARP\_REQUEST for a SOURCE-LAN-DESTINATION not in its cache SHOULD ignore the request. An LE Client receiving a targetless LE\_ARP\_REQUEST for a SOURCE-LAN-DESTINATION that is in its cache SHOULD update that cache entry with the information in the LE\_ARP\_REQUEST. This technique ensures that the LE Client has up-to-date information, without filling its LE\_ARP cache entries for which it has no use.

### 7.1.31 No-source LE\_NARP\_REQUEST

An LE Client MAY generate a no-source LE\_NARP\_REQUEST to notify other clients that it no longer represents the unicast LAN Destination in TARGET-LAN-DESTINATION and TARGET-ATM-ADDRESS (and LLC-Muxed-ATM-Address TLV, if present). In this case, SOURCE-ATM-ADDRESS MUST be zero.

### 7.1.32 LE\_NARP and Targetless LE\_ARP Time Limits

LE\_NARP\_REQUESTs and targetless LE\_ARP\_REQUESTs are broadcast messages which are unacknowledged and therefore are not reliably delivered. Due to this, an LE Client MAY choose to retransmit these requests as needed. However, an LE Client MUST NOT transmit an LE\_NARP\_REQUEST or a targetless LE\_ARP\_REQUEST for the same unicast LAN Destination more often than once every second.

### 7.1.33 LE\_NARP\_REQUESTs and Targetless LE\_ARP\_REQUESTs and Topology Changes

An LE Client MUST NOT generate an LE\_NARP\_REQUEST for any LAN destination, or a targetless LE\_ARP\_REQUEST for a remote LAN Destination (a LAN destination in its C27 or C30 variables), when its C19 **Topology Change** flag is set, i.e., when there are more general topology changes occurring in the network. An operational LE Client MAY generate a targetless LE\_ARP\_REQUEST for a local LAN Destination (one of its variables C6 **Local Unicast MAC Address(es)** or C8 **Local Route Descriptor(s)**) at any time.

### 7.1.34 LE\_NARP\_REQUESTs For Local Bindings

An LE Client MUST NOT generate LE\_NARP\_REQUESTs for Local bindings, i.e. for bindings for which it uses the LE\_REGISTER/UNREGISTER mechanism.

### 7.1.35 Updating the LE\_ARP Cache

If the client receives a valid LE\_NARP\_REQUEST with a SOURCE-LAN-DESTINATION that matches an existing entry in its LE\_ARP cache, it MUST delete the entry. If the SOURCE-ATM-ADDRESS is non-zero, the

LE Client MAY add the entry to its LE\_ARP cache.<sup>22,23</sup> In this case, the LE Client MUST associate the TLVs in the LE\_NARP\_REQUEST with the new entry.

### 7.1.36 Learning New LE\_ARP Cache Entries

An LE Client MAY learn new entries for its LE\_ARP cache by observing the source MAC address of a frame received on a Data Direct VCC, and associate that MAC address with the VCC and/or the ATM address of the LE Client at the other end of the VCC. Any such learned MAC address MUST be learned as a Remote MAC Address (C27). The entry is learned without any associated TLVs.

## 7.2 Address Resolution - LE Service View

### 7.2.1 Address Resolution VCC

An LE Server MUST ignore any LE\_ARP\_REQUEST or LE\_ARP\_RESPONSE received on any VCC other than a Control Direct VCC.

### 7.2.2 Transmitting LE\_ARP\_REQUESTs and LE\_ARP\_RESPONSEs

If an LE Server sends an LE\_ARP\_REQUEST or LE\_ARP\_RESPONSE to an LE Client, it must send it on the Control Direct VCC (to that client) or the Control Distribute VCC (to that client and/or other LE Clients).

### 7.2.3 Responding to LE\_ARP\_REQUESTs for Known Unicast LAN Destinations

An LE Server MAY respond to an LE\_ARP\_REQUEST for a registered Route Descriptor or unicast MAC address with the information obtained when that unicast LAN Destination was registered. The Remote Address bit Flag in this LE\_ARP\_RESPONSE MUST be cleared. The LE Server MUST include in the LE\_ARP\_RESPONSE any and all TLVs registered with that unicast LAN Destination.

### 7.2.4 Not Responding to Unknown LE\_ARP\_REQUESTs

An LE Server MUST NOT respond to an LE\_ARP\_REQUEST for a unicast LAN Destination that has not been registered.

### 7.2.5 Not Forwarding Known LE\_ARP\_REQUESTs

If an LE Server responds to an LE\_ARP\_REQUEST, it MUST NOT also forward that LE\_ARP\_REQUEST to any LE Client.

### 7.2.6 Responding to LE\_ARP\_REQUESTs for Multicast MAC Addresses

The LE Service MUST respond to every LE\_ARP request for a multicast MAC address with an ATM address of the BUS, provided that the request comes from an LE Client whose LE\_JOIN\_REQUEST contained both the V2 Capable and Selective Multicast FLAGS bits, and whose successful LE\_JOIN\_RESPONSE contained the V2 Capable TLV. The LE Service MAY terminate the ELAN membership of any other LE Client which issues an LE\_ARP\_REQUEST for a multicast MAC address.

---

<sup>22</sup>IEEE 802.1D bridges which learn from packet source addresses will probably not gain very much from either generating or learning LE\_NARP\_REQUESTs. They achieve a better effect by performing source-address learning.

<sup>23</sup>Use of LE\_NARP\_REQUESTs does not resolve the problem of having to deal with LECs using long timeouts: LECs may still receive more than one LE\_NARP\_REQUEST with contradictory information at regular intervals until the responders resolve who is really representing the LAN Destination, just as they may also receive more than one LE\_ARP\_RESPONSE for a single LE\_ARP\_REQUEST for a destination that multiple LECs believe is theirs to represent.

### 7.2.7 Forwarding LE\_NARP\_REQUESTs and Targetless LE\_ARP\_REQUESTs

An LE Server MUST forward any valid LE\_NARP\_REQUESTs or targetless LE\_ARP\_REQUESTs to all LE Clients.

### 7.2.8 Forwarding LE\_ARP\_REQUESTs

If the LE Server does not respond to an LE\_ARP\_REQUEST for a registered unicast LAN Destination, then it MUST forward the LE\_ARP\_REQUEST to the LE Client that registered that unicast LAN Destination. The LE Server MAY also forward that LE\_ARP\_REQUEST to other LE Clients, as well.

### 7.2.9 Forwarding LE\_ARP\_REQUESTs to Proxy LE Clients

An LE Server MUST forward any LE\_ARP\_REQUEST for an unregistered unicast LAN Destination to all LE Clients that successfully joined as proxy agents (Proxy Flag in the LE\_JOIN\_REQUEST). The LE Server MAY also forward that LE\_ARP\_REQUEST to other LE Clients, as well.

### 7.2.10 Responding to LE\_ARP\_REQUESTs for Broadcast LAN Destination

The LE Service MUST respond to every LE\_ARP request for the broadcast LAN Destination with the ATM address of the BUS.

### 7.2.11 Forwarding LE\_TOPOLOGY\_REQUESTs

The LE Server MUST send one LE\_TOPOLOGY\_REQUEST to all LE Clients for each valid LE\_TOPOLOGY\_REQUEST received from any client. The Topology Change bit in the FLAGS field in the LE\_TOPOLOGY\_REQUEST SHOULD match that of the LE\_TOPOLOGY\_REQUEST last received by the LE Server.

### 7.2.12 Initiating LE\_TOPOLOGY\_REQUESTs

An LE Server MAY issue LE\_TOPOLOGY\_REQUESTs without receiving any LE\_TOPOLOGY\_REQUESTs. For example, an LE Server may wish to clear the LE Clients' Topology Change flags if all its transparent bridge LE Clients cease operations while the other LE Clients' Topology Change flags are set.

### 7.3 Address Resolution Frames

The LE\_ARP frames used to resolve LAN Destinations to ATM addresses, and thus VCCs, are described in Table 30.

Table 30. LE\_ARP Frame Format

Offset	Size	Name	Function
0	2	MARKER	Control Frame = X"FF00"
2	1	PROTOCOL	ATM LAN Emulation protocol = X"01"
3	1	VERSION	ATM LAN Emulation protocol version = X"01"
4	2	OP-CODE	Type of request: X"0006" LE_ARP_REQUEST X"0106" LE_ARP_RESPONSE
6	2	STATUS	Always X"0000" in requests. In Responses: See Table 18 for a list of values.
8	4	TRANSACTION-ID	Arbitrary value supplied by the requester.
12	2	REQUESTER-LECID	LECID of LE Client issuing the LE_ARP request.
14	2	FLAGS	Each bit of the FLAGS field has a separate meaning if set:  X"0001" Remote Address. For LE_ARP_REQUEST, the SOURCE-LAN-DESTINATION is not registered with the LE Server. For LE_ARP_RESPONSE, the TARGET-LAN-DESTINATION is not registered with the LE Server.
16	8	SOURCE-LAN-DESTINATION	Source MAC address from data frame that triggered this LE_ARP sequence. May be encoded with "not present" LAN Destination tag.
24	8	TARGET-LAN-DESTINATION	Destination unicast MAC address or next Route Descriptor for which an ATM address is being sought. "Not Present" for a targetless LE_ARP_REQUEST.
32	20	SOURCE-ATM-ADDRESS	Non-multiplexed ATM address unique to requestor LE Client or X"00" if not present.
52	2	RESERVED	Always X"00" when sent, ignored on receipt.
54	1	NUMBER-TLVs	Number of Type/Length/Value elements encoded in request/response.
55	1	RESERVED	Always X"00" when sent, ignored on receipt.
56	20	TARGET-ATM-ADDRESS	X"00" in LE_ARP request. Non-multiplexed ATM address of LE Client responsible for target LAN Destination in LE_ARP response.
76	32	RESERVED	Always X"00" when sent, ignored on receipt.
108	var	TLVs	



### 7.3.1 LE\_ARP Supported TLVs

The following table describes the TLV encodings used in LE\_ARP\_REQUEST and LE\_ARP\_RESPONSE frames.

Table 31. LE\_ARP Frame - Supported TLVs

Item	Version
LLC-Muxed-ATM-Address	LANE v2
Service-Category	LANE v2
User Defined TLVs	LANE v2

### 7.4 LE\_NARP Frame Format

Table 32. LE\_NARP Frame Format

Offset	Size	Name	Function
0	2	MARKER	Control Frame = X"FF00"
2	1	PROTOCOL	ATM LAN Emulation protocol = X"01"
3	1	VERSION	ATM LAN Emulation protocol version = X"01"
4	2	OP-CODE	Type of request: X"0008" LE_NARP_REQUEST
6	2	STATUS	Always X"0000".
8	4	TRANSACTION-ID	Arbitrary value supplied by the requester.
12	2	REQUESTER-LECID	LECID of LE Client issuing the LE_NARP request.
14	2	FLAGS	Always X"00" when sent, ignored on receipt.
16	8	SOURCE-LAN-DESTINATION	Not used. Encoded as X"00".
24	8	TARGET-LAN-DESTINATION	Destination unicast MAC address or next Route Descriptor for which the target ATM address no longer applies.
32	20	SOURCE-ATM-ADDRESS	Non-multiplexed ATM address unique to requestor, or X"00" for no-source LE_NARP_REQUEST.
52	2	RESERVED	Always X"00" when sent, ignored on receipt.
54	1	NUMBER-TLVs	Number of Type/Length/Value elements encoded in request.
55	1	RESERVED	Always X"00" when sent, ignored on receipt.
56	20	TARGET-ATM-ADDRESS	Non-multiplexed ATM address of LE Client which was previously representing the target LAN Destination.
76	32	RESERVED	Always X"00" when sent, ignored on receipt.
108	var	TLVs	

### 7.4.1 LE-NARP Supported TLVs

The following table describes the TLV encodings used in LE\_NARP\_REQUEST frame.

**Table 33. LE NARP Request Frame - Supported TLVs**

Item	Version
LLC-Muxed-ATM-Address	LANE v2
Service-Category	LANE v2

## 7.5 Topology Change Frames

Topology Change frames are used for notifying all LE Clients that their cached LE\_ARP information for remote LAN Destinations may be incorrect. They are described in Table 34.

**Table 34. Topology Change Frame Format**

Offset	Size	Name	Function
0	2	MARKER	Control Frame = X"FF00"
2	1	PROTOCOL	ATM LAN Emulation protocol = X"01"
3	1	VERSION	ATM LAN Emulation protocol version = X"01"
4	2	OP-CODE	Type of request: X"0009" LE_TOPOLOGY_REQUEST
6	2	STATUS	Always X"0000"
8	4	TRANSACTION-ID	Arbitrary value supplied by the requester.
12	2	REQUESTER-LECID	LECID of LE Client issuing the Topology Change request.
14	2	FLAGS	Each bit of the FLAGS field has a separate meaning if set: X"0100" Topology Change Flag. A network topology change is in progress.
16	92	RESERVED	Always X"00" when sent, ignored on receipt.

## 8. Data Transfer Protocol and Procedures

### 8.1 Data Transfer Phase - LE Client Protocol Mechanisms

#### 8.1.1 Data Frame VCC

An LE Client MUST NOT send unicast data frames over any VCCs except Data Direct VCCs and the Default Multicast Send VCC. An LE Client MUST NOT send multicast data frames over any VCCs except the Default Multicast Send VCC or any Selective Multicast Send VCC.

#### 8.1.2 Data Frame Frequency

An LE Client MUST send no more than **C10 Maximum Unknown Frame Count** frames within a time period of **C11 Maximum Unknown Frame Time** seconds to a given unicast LAN Destination to the Broadcast and Unknown Server. If a multicast address has been resolved to the same ATM address as the BUS, then the LE Client MAY send frames at an unrestricted rate to the BUS over the Default Multicast Send VCC.

#### 8.1.3 Use of LECID

An LE Client MUST either insert its own LECID (parameter **C14**) or X'0000' in the LE HEADER field of any data frame it sends on a data connection. An LE Client MUST insert its own LECID (**C14**) in the LE-HEADER field on any data frame it sends on the Default Multicast Send VCC and any Selective Multicast Send VCC.

#### 8.1.4 Discarding Frames Based on LECID

An LE Client MAY examine all frames received on Multicast Send VCCs or Multicast Forward VCCs, and discard any frames having its own LECID. An LE Client MUST ignore the LECID of data frames received on Data Direct VCCs.

#### 8.1.5 Discarding Frames Based on ELAN-ID

An LE Client MUST examine all LLC-multiplexed frames received on any LLC-multiplexed Data Direct VCC, and discard any frames having an ELAN-ID not matching its own variable **C31**.<sup>24</sup>

#### 8.1.6 Maximum Frame Sizes

An LE Client MUST NOT send any frame that is larger than its Maximum Frame Size parameter **C3 Maximum Data Frame Size** on any non-multiplexed data VCC or that **C3 Maximum Data Frame Size** value plus 12 octets on any LLC-multiplexed Data Direct VCC.

#### 8.1.7 Forwarding Data Frames

An LE Client MUST NOT forward any data frame received on a Data Direct VCC, a Multicast Send VCC or a Multicast Forward VCC to any Data Direct VCC or Multicast Send VCC for the same emulated LAN. This restriction applies to LE Clients in bridges, as well as non-bridges. This is a restriction on the LE Client itself, not the higher-level entities making use of the LE Client's facilities.

---

<sup>24</sup>When a device has multiple LE Clients (and/or other protocol entities) sharing the same VCC, this specification assumes that the device will use LLC and ELAN-ID to determine which entity will receive which frames. With such a demultiplexing function, an LE Client will not receive frames that it is required to discard due to incorrect ELAN-ID.

### 8.1.8 Filtering Data Frames

Each client is responsible for filtering out only those destinations which it needs to deliver up to higher layers (See service definition interface, as well as parameter **C15**).

### 8.1.9 Minimum IEEE 802.3 Data Frame Size

An LE Client **MUST NOT** transmit an IEEE 802.3/Ethernet data frame with an AAL5 SDU size of less than 62 octets on non-multiplexed VCCs, or less than 74 octets on LLC-multiplexed VCCs.

### 8.1.10 Minimum IEEE 802.5 Data Frame Size

An LE Client **MUST NOT** transmit an IEEE 802.5 data frame with an AAL5 SDU size of less than 16 octets on non-multiplexed VCCs, or 28 octets on LLC-multiplexed VCCs.

### 8.1.11 Maximum Data Frame Size (C3)

An LE Client using SVCs **MUST** signal the **C3 Maximum Data Frame Size** as both the Forward Maximum CPCS-SDU size and the Backward Maximum CPCS-SDU size for establishing all non-multiplexed Data Direct and Multicast Send VCCs, and a minimum of **C3 Maximum Data Frame Size** plus 12 octets for the LLC-multiplexed Data Direct VCCs. An LE Client **MUST** refuse to establish non-multiplexed VCCs with any other Forward Maximum CPCS-SDU size or Backward Maximum CPCS-SDU size. An LE Client **MUST NOT** refuse to establish LLC-multiplexed VCCs with Forward Maximum CPCS-SDU size or Backwards Maximum CPCS-SDU size greater than **C3 Maximum Data Frame Size** plus 12 but **MAY** negotiate them down to **C3 Maximum Data Frame Size** plus 12.

### 8.1.12 Refusing VCCs with Incorrect B-LLI Values

An LE Client **SHOULD** refuse an incoming Data Direct VCC connection request whose B-LLI value indicates a non-multiplexed VCC, but whose called party ATM address is not included in the LE Client's variable **C1n**. An LE Client **MAY** refuse an incoming Data Direct VCC connection request whose B-LLI value indicates an LLC-multiplexed VCC, but whose called party ATM address is not included in the LE Client's variable **C1m**. (This latter refusal may be inappropriate if the LE Client is multiplexing VCCs with other protocols besides LANE.)

### 8.1.13 Duplicate Incoming Data Direct VCC

When a client receives an incoming Data Direct VCC connection request from an ATM address and B-LLI value to which it already has a connection, it **SHOULD** accept that request. Thus an LE Client may have several Data Direct VCCs to a particular destination.

When an LE Client is told to send a data frame via LE\_UNITDATA.request, it **SHOULD** use a VCC matching the QoS requested for that frame (as described in Section 3.1). If multiple matching VCCs exist, the LE Client **MUST** use the VCC whose calling party ATM address is numerically lower than the called party address. If multiple such VCCs exist, the VCC which was the earliest created (that is, the VCC whose SETUP or CONNECT message was received first) **MUST** be used.

Following these rules may cause duplicate VCCs to be aged out due to inactivity without the possibility of a race condition removing too many VCCs.

### 8.1.14 Data Direct VCC Termination

An LE Client **SHOULD** terminate Data Direct VCCs over which no traffic has been sent or received for a minimum length of time **C12**. It **MUST** indicate the UNI Cause Code (for example UNI 3.0 Cause "Normal, Unspecified" Cause 31) so that the other end can distinguish between accidental failures and deliberate dropping of the VCC.

### 8.1.15 Terminating ELAN Membership

If the LE Client detects that the Control Direct VCC or the Control Distribute VCC is released at any time other than those specified for the "Join" phase above, then the LE Client **MUST** terminate its ELAN membership.

## 8.2 Data Direct Call Establishment

### 8.2.1 Selecting Service Category for Data Direct VCCs

When an LE Client knows that the desired Service Category is supported on the target LE Client, it MAY set up the data direct VCC with that Service Category, in which case the call setup will likely succeed in one setup cycle. If the first attempt for the call setup does not succeed, the LE Client MAY attempt with another Service Category that both ends support. The LE Client MUST attempt to setup a UBR connection if the first or subsequent call setup attempts using different Service Categories fail.

### 8.2.2 Client Ready to Receive Frames

A called LE Client accepting any point-to-point VCC MUST NOT issue a CONNECT message until it is ready to receive frames on that VCC. It then MAY establish a time-out C28.

### 8.2.3 Choice of LLC-Multiplexed or Non-Multiplexed VCC

If an LE Client uses the SOURCE-ATM-ADDRESS or TARGET-ATM-ADDRESS of an LE\_ARP\_REQUEST or LE\_ARP\_RESPONSE to obtain the other LE Client's ATM address for a Data Direct VCC, it MUST establish a non-multiplexed Data Direct VCC. If the LE Client uses the LLC-Muxed-ATM-Address TLV of an LE\_ARP\_REQUEST or LE\_ARP\_RESPONSE to obtain the other LE Client's ATM address for a Data Direct VCC, it MUST establish an LLC-multiplexed Data Direct VCC.

### 8.2.4 Calling Client Action on Receiving CONNECT Message

An LE Client that receives a CONNECT message for a requested Data Direct VCC MUST issue a READY\_IND message as soon as it is ready to accept frames on that VCC. It then MAY also send data or flush frames. It MUST NOT send any frames before it is ready to accept frames. Data or Flush frames MAY be sent before the READY\_IND message.

### 8.2.5 Called Client Timer C28 Expires

If time-out C28 expires, the LE Client MAY transmit data or a READY\_QUERY frame. It MAY re-establish time-out C28, and repeat this as desired.

## 8.3 Data Transfer Phase - BUS Protocol Mechanisms

### 8.3.1 Maximum Frame Age S5

The BUS MUST discard any frame which has been held in the BUS for longer than the S5 Maximum Frame Age, regardless of other provisions in Section 8.3.

### 8.3.2 BUS Forwarding Unicast Data Frames

The BUS SHOULD forward unchanged any valid unicast data frame received from Multicast Send VCCs on an appropriate combination of Multicast Send VCCs and/or Multicast Forward VCCs such that it is delivered at most once to every LE Client, and exactly once to each LE Client which might serve the frame's destination MAC address.

### 8.3.3 BUS Forwarding Broadcast Data Frames

All broadcast and multicast traffic received by a BUS MUST be forwarded unchanged on a Multicast Forward VCC to the appropriate LE Client(s). The BUS MUST forward all data frames received to LE Clients which joined with either of the V2 Capable or Selective Multicast FLAGS bits clear in the Join Request. The BUS MUST forward all broadcast and unicast data frames received to LE Clients which joined with both of the V2 Capable and Selective Multicast FLAGS bits set in the Join Request.

### 8.3.4 BUS Forwarding Multicast Data Frames

All multicast traffic received by a BUS MUST be forwarded onto an appropriate combination of Multicast Send VCCs and/or Multicast Forward VCCs such that it is delivered exactly once to those LE Clients which have registered to receive the frame's multicast destination, exactly once to those LE Clients whose **C32 Selective Multicast** variable is clear, and at most once to any other LE Client.

### 8.3.5 BUS forwarding of Token Ring ARE and STE frames

The BUS MUST forward Token Ring ARE and STE frames to at least all LE Clients which joined the ELAN with the Token Ring Explorer Exclude Flag clear and the LE Client which registered the destination MAC address, if any.

### 8.3.6 Selection of Multicast Forward and Multicast Send VCCs

A BUS MAY choose any algorithm for selecting the appropriate combination of Multicast Send VCCs and Multicast Forward VCCs which meets the above constraints, where delivery to an LE Client requires a frame be sent on a VCC attached to the LE Client's primary ATM address.

## 8.4 Data Transfer Phase - LES Protocol Mechanisms

### 8.4.1 LE Server Detects VCC Release and Terminates ELAN Membership

If the LE Server detects that the Control Direct VCC or the Control Distribute VCC to/from a client are released, then the LE Server MUST terminate the emulated ELAN membership of the LE Clients using that Control Direct or Control Distribute VCC.

### 8.4.2 LE Server Terminates ELAN Membership

At any time during the data transfer phase, the LE Server may close the Control Direct or the Control Distribute VCC to a client with Reason Code 31 in order to terminate the emulated ELAN membership of all LE Clients using that Control Direct or Control Distribute VCC.

## 8.5 Delivery of Token Ring Frames

When the LE Client has a frame to send it examines both the frame's routing information field and the frame's destination MAC address field to determine where to send the frame and if it should LE\_ARP. An LE Client emulating Token Ring MUST support address resolution of route descriptors. Appendix B.2 provides information on determining if a frame is a source routed frame (contains an RI field), determining the RI type, and determining the next RD. A frame is classified as being a Non Source Routed (NSR), All Routes Explorer (ARE), Spanning Tree Explorer (STE), or a Specifically Routed Frame (SRF).

The following requirements are based on NSR traffic being sent on a VCC determined by the frame's DA and source route traffic being sent on a VCC determined by the frame's RI field and DA field. The resulting actions and operations are summarized in Table 35 and Table 36.

### 8.5.1 Bridge Response to LE\_ARP

A source routing bridge MUST respond to an LE\_ARP\_REQUEST for one of its RDs.

### 8.5.2 NSR Frames

An LE Client **MUST** send an NSR frame on the data direct VCC for the frame's DA. If the VCC is unknown, then the LE Client **MUST** generate an LE\_ARP\_REQUEST for the DA and the frame **MAY** be sent to the BUS.

### 8.5.3 Multicast Frames

An LE Client **MUST** send multicast frames to the BUS according to the same rules as for an IEEE 802.3/Ethernet LE Client, using LE\_ARP for multicast MAC addresses.

### 8.5.4 ARE, STE Frames

An LE Client **MUST** send an ARE or an STE frame to the BUS. If the LE Client is part of a source routing bridge, then the appropriate Route Descriptor needs to be added to the RIF and the LTH needs to be recalculated.

### 8.5.5 RI Field Length

An LE Client that is not part of a bridge may assume that if the RI field of an SRF frame has a length of 6 or more, then the local SEGMENT ID is the first RD in the list and the "next RD" is SEGMENT ID of the second RD in the list (order depending on the RI direction bit) and the Bridge number located between those two SEGMENT IDs (refer to Appendix 12.3.2.3 for information on determining the next RD). This implies that the last hop is not this ELAN.

### 8.5.6 Invalid RI Field

The LE Client **MAY** discard a frame with an invalid RI field. This includes an RI field with an odd length and a SRF frame with an RI field that does not contain an RD matching the emulated LAN's SEG\_ID.

### 8.5.7 No Hops

An SRF frame with a RI length less than 6 contains no hops. An LE Client **MUST** send a SRF frame with no hops on the direct VCC for the frame's DA. If the VCC is unknown, then the LE Client **MUST** generate an LE\_ARP\_REQUEST for the DA and the frame **MAY** be sent to the BUS.

### 8.5.8 Last Hop on Same ELAN

If the last hop of a SRF frame is this ELAN, then the LE Client **MUST** send the frame on the direct VCC for the frame's DA. If the VCC is unknown, then the LE Client **MUST** generate an LE\_ARP\_REQUEST for the DA and the frame **MAY** be sent to the BUS.

### 8.5.9 Next RD

If the length of a SRF frame's RI field is 6 or more and this ELAN is not the last hop, then the LE Client **MUST** send the frame on the direct VCC for the "next\_RD". If the VCC for the "next\_RD" is unknown, then the LE Client **MUST** generate an LE\_ARP\_REQUEST for the "next\_RD" and the frame **MAY** be sent to the BUS.

**Table 35. LAN Destination of Token Ring Frames**

Frame Type	Destination Address:	
	Unicast:	Multicast:
Non source Routed (NSR)	VCC(DA)	BUS
Explorer (ARE or STE)	BUS	BUS
Specifically Routed (SRF)	Table 36	BUS

**VCC(DA):** Use the frame's DA as the basis for delivering the frame. If the VCC is not known, LE\_ARP with the DA as the target address.

**BUS:** Send to the BUS.

**Table 36:** If this is the last hop then use the DA otherwise use the RD as summarized in Table 36 (which follows).

**Table 36. LAN Destination for Unicast SRF Token Ring Frames**

Routing Information	Destination:
No hops	VCC(DA)
Last hop	VCC(DA)
Not last hop	VCC(next_RD)

**VCC(DA):** Use the frame's DA as the basis for delivering the frame. If the VCC is not known, LE\_ARP with the DA as the target address.

**VCC(next\_RD):** Use the next\_RD as the basis for delivering the frame. If the VCC is not known, LE\_ARP with the next\_RD as the target address.

## 8.6 Maximum Data Frame Size.

As stated in Section 1, the main objective of the LAN emulation service is to enable existing applications to access an ATM network as if they were running over traditional LANs. An emulated LAN corresponds more or less to a single LAN segment, and an LE Client corresponds more or less to a NIC. In a traditional LAN, MTU is the same for all adapters on a given LAN segment regardless of destination address. In order to support conventional LAN services where the maximum frame size is the same for all adapters on a given LAN segment, all LE clients that belong to a given emulated LAN use the same maximum AAL5 SDU size for all their connections.



The LAN Emulation components MUST use one of the maximum AAL5 SDU sizes of 1516, 1580, 4544, 9234, and 18190 octets for non-multiplexed data frames - and for establishing non-multiplexed data SVCs. The corresponding AAL5 SDU sizes for LLC-multiplexed data frames on LLC-multiplexed VCCs are 1528, 1592, 4556, 9246, and 18202, respectively. These sizes have been selected to support bridging to existing LANs. The basis for these sizes follow and is summarized in B.1 in the Appendix. However, shared LLC-multiplexed Data Direct connections MAY be signalled with a larger AAL5 maximum SDU size than that used by the LE Client so they may be shared with other protocols (or LE Clients) using different maximum AAL5 SDU sizes.

**Table 37. Maximum Data Frame Size**

Non Muxed AAL5 SDU Max. octets (LLC Muxed)	Non Muxed AAL5 PDU Max. octets (LLC Muxed)	Basis for SDU Size
1516 (1528)	1536 (1536) = 32 cells (32)	IEEE 802.3/Ethernet
1580 (1592)	1632 (1632) = 34 cells (34)	IEEE 802.1p/Q [Note: These are draft documents not yet publicly available from the IEEE]
4544 (4556)	4560 (4608) = 95 cells (96)	IEEE 802.5 Token Ring 4Mbps
9234 (9246)	9264 (9264) = 193 cells (193)	RFC 1626
18190 (18202)	18240 (18240) = 380 cells (380)	IEEE 802/5 Token Ring 16Mbps

## 9. Verify Protocol, Procedures and Frame Formats

The verify protocol allows an LE Client to check whether the calling party ATM Address used to establish one or more Multicast Forward VCCs to that LE Client is recognized by the LE Server as being a valid BUS Address for this ELAN. Note that an LE Client MAY have Multicast Forward VCCs established to it from multiple different ATM Addresses and it MAY want to verify each of them. This protocol is only used when an LE Client's variable **C29 V2 Capable** is set.

Verify protocol frames are of two types:

- **LE\_VERIFY\_REQUEST:** Sent by the LE Client to the LE Server. Requests that the LE Server verifies that the specified ATM address is a valid BUS ATM Address for that ELAN.
- **LE\_VERIFY\_RESPONSE:** Sent by the LE Server to the LE Client in response to an LE\_VERIFY\_REQUEST frame. Confirms or denies the ATM Address from the request as a valid BUS ATM Address for the ELAN.

These frame formats are described in **Table 38**.

### 9.1 Verification Procedures

#### 9.1.1 Verification - LE Client View

##### 9.1.1.1 Sending LE\_VERIFY\_REQUEST frames

Verification protocol frames MUST only be sent by an LE Client over the Control Direct VCC. An LE Client MUST not send any LE\_VERIFY\_REQUEST frames if its variable **C29 V2 Capable** is clear.

##### 9.1.1.2 Ignoring Verification Frames

An LE Client MUST ignore any verification protocol frames received over any VCC other than the Control Direct VCC or the Control Distribute VCC.

##### 9.1.1.3 Optional Verification Protocol

An LE Client MAY send an LE\_VERIFY\_REQUEST to the LE Server to verify an ATM Address as being one of the BUS for this ELAN. This request MUST contain the requester's LEC ID and the ATM Address to verify.

##### 9.1.1.4 Ignoring LE\_VERIFY\_REQUEST

An LE Client MUST ignore a LE\_VERIFY\_RESPONSE containing a REQUESTER-LECID different from its own LECID.

##### 9.1.1.5 Receiving LE\_VERIFY\_RESPONSE

If an LE Client receives an LE\_VERIFY\_RESPONSE in response to an LE\_VERIFY\_REQUEST sent by that LE Client with a non-zero status, it SHOULD release any Multicast Forward VCCs from the ATM Address specified in the TARGET-ATM-ADDRESS field of the LE\_VERIFY\_RESPONSE (UNI Reason Code "Normal, Unspecified" - Cause 31) irrespective of any other provisions in this document.

##### 9.1.1.6 Duplicate Verification Frame Frequency

An LE Client MUST NOT repeat an LE\_VERIFY\_REQUEST for the same ATM address more often than once per second.

##### 9.1.1.7 Optional Termination

If an LE Client is unable to obtain a verification response from the LE Server after some number of attempts to verify an ATM Address, it MAY terminate the ELAN membership.

##### 9.1.1.8 Ignoring Request Frames

An LE Client MUST NOT respond to an LE\_VERIFY\_REQUEST.

## 9.1.2 Verification - LE Server View

### 9.1.2.1 LE\_VERIFY\_RESPONSE Frames

An LE Server MUST send all LE\_VERIFY\_RESPONSE frames over the Control Direct VCC or the Control Distribute VCC (if it exists) to an LE Client. LE\_VERIFY\_RESPONSE frames MUST be sent to at least the LE Client specified in the REQUESTER-LECID field and MAY be sent to other LE Clients.

### 9.1.2.2 Ignoring Verification Frames

An LE Server MUST ignore all verification protocol frames received over any VCC other than a Control Direct VCC.

### 9.1.2.3 Responding to LE\_VERIFY\_REQUEST frames

An LE Server MUST respond to every valid LE\_VERIFY\_REQUEST frame received with an LE\_VERIFY\_RESPONSE frame. If the ATM Address specified in the TARGET-ATM-ADDRESS field of the LE\_VERIFY\_REQUEST is not a valid ATM Address for the BUS on this ELAN appropriate for the requesting LE Client, the LE\_VERIFY\_RESPONSE MUST be returned with the STATUS code "Invalid ATM Address".

## 9.2 Verify Frames

Table 38 describes Verify frames, which are used to check that BUS ATM Addresses are valid for the ELAN.

Table 38. Verify Frame Format

Offset	Size	Name	Function
0	2	MARKER	Control Frame = X"FF00"
2	1	PROTOCOL	ATM LAN Emulation protocol = X"01"
3	1	VERSION	ATM LAN Emulation protocol version = X"01"
4	2	OP-CODE	Type of request: X"000A" LE_VERIFY_REQUEST X"010A" LE_VERIFY_RESPONSE
6	2	STATUS	Always X"0000" in requests. In Responses: See Table 18 for a list of values.
8	4	TRANSACTION-ID	Arbitrary value supplied by the requester and returned by the responder.
12	2	REQUESTER-LECID	LECID of LE Client issuing the verify request and returned by the responder.
14	2	FLAGS	Always X"00" when sent, ignored on receipt.
16	38	RESERVED	Always X"00" when sent, ignored on receipt.
54	1	NUMBER-TLVS	Number of Type/Length/Value elements encoded in Request/Response.
55	1	RESERVED	Always X"00" when sent, ignored on receipt.
56	20	TARGET-ATM-ADDRESS	ATM Address to be checked by LE Server.
76	32	RESERVED	Always X"00" when sent, ignored on receipt.
108	Var	TLVs	

## 10. Flush Message Protocol, Procedures and Frame Formats

A LAN emulation client may send frames to the same LAN Destination via the Broadcast and Unknown Server, or via Data Direct VCCs at different times. The flush message protocol allows the sender to avoid the possibility of delivering unicast<sup>25</sup> frames out of order caused by having multiple paths. When switching from the “old” path to the “new” path, the sender first transmits a flush message down the old path, then sets appropriate table entries so that any further frames for the given LAN Destination will be held (or discarded) at the sender and not transmitted. The flush message is a special frame distinguishable from a data frame by having a reserved value (X'FF00', marker for control frame) in the LAN emulation data frame header in place of the LECID of the sender. The flush message must be returned to the sender by the receiving client via control VCCs. Once the sender receives the returned flush message, it knows that the old path is clear of data for that LAN Destination, and it can start using the new path.

Note that Flush messages may be exchanged between LE Clients, but are never forwarded by a bridge to a traditional LAN. Because they travel over Data Direct VCCs, the LE\_FLUSH\_REQUEST is the only control frame that uses the LLC multiplexed control frame format described in Table 14.

### 10.1 Flush Message Protocol and Procedures

The Flush Message Protocol ensures that data frames are delivered in the same order that they were transmitted. Flush Protocol messages are of two types, each in two formats, non-multiplexed and LLC-multiplexed:

- **LE\_FLUSH\_REQUEST:** Flush requests are sent by an LE Client down a Data Direct VCC or the Default Multicast Send VCC to ensure that all data frames in transit on that path have reached their destination LE Client.
- **LE\_FLUSH\_RESPONSE:** Flush responses are returned by LE Clients via Control Direct VCCs and Control Distribute VCCs in response to received LE\_FLUSH\_REQUESTs.

These frame formats are described in Table 39.

#### 10.1.1 Mandatory Protocol

The following requirements apply to any LE Client or LE Service Component, whether or not the LE Client chooses to implement the flush message protocol for ensuring the order of delivery for data frames.

##### 10.1.1.1 LE\_FLUSH\_REQUEST VCC

An LE Client MAY send an LE\_FLUSH\_REQUEST over any Data Direct VCC or Default Multicast Send VCC.

##### 10.1.1.2 Ignoring LE\_FLUSH\_REQUEST Prior to Join

An LE Client MUST NOT respond to an LE\_FLUSH\_REQUEST arriving on a VCC associated with an ATM Emulated LAN for which the LE Client has not successfully completed the Join procedure, regardless of any other provisions in Section 10.1.1.

##### 10.1.1.3 Forwarding LE\_FLUSH\_REQUESTs

The BUS MUST distribute any LE\_FLUSH\_REQUEST received via a Default Multicast Send VCC to at least the LE Client specified in that frame's target ATM address via a Default Multicast Send VCC or a Multicast Forward VCC, if that LE\_FLUSH\_REQUEST does not specify the BUS's ATM address as its target. If the TARGET-LAN-DESTINATION is present in that LE\_FLUSH\_REQUEST the BUS MUST distribute the LE\_FLUSH\_REQUEST to the target LE Client on the VCC that would be used to forward data frames to the target LAN Destination specified in the LE\_FLUSH\_REQUEST frame. The BUS MAY distribute requests targeted to its own ATM addresses, as well.

---

<sup>25</sup> For multicast frames, see Section 10.1.3.

#### 10.1.1.4 Responding to LE\_FLUSH\_REQUEST on Control Direct VCC

An LE Service Component MAY respond to an LE\_FLUSH\_REQUEST directed to that LE Service component. If it does respond, it MUST respond to an LE\_FLUSH\_REQUEST specifying its own ATM address as the target in such a manner that the LE\_FLUSH\_RESPONSE will be returned to the requester on a Control VCC.

#### 10.1.1.5 Responding to LE\_FLUSH\_REQUEST

An LE Client MUST respond to an LE\_FLUSH\_REQUEST it receives on any VCC if that LE\_FLUSH\_REQUEST specifies one of that LE Client's ATM addresses as its target, by returning an LE\_FLUSH\_RESPONSE to the sender of the LE\_FLUSH\_REQUEST. The responding LE Client MUST use its Control Direct VCC to send the response.

#### 10.1.1.6 Ignoring LE\_FLUSH\_REQUEST

An LE Client MUST NOT respond to an LE\_FLUSH\_REQUEST with a TARGET-ATM-ADDRESS that is not its own.

#### 10.1.1.7 Forwarding LE\_FLUSH\_RESPONSE

The LE Server MUST relay LE\_FLUSH\_RESPONSEs whose SOURCE-ATM-ADDRESS field matches the information in the REQUESTER-LECID field to at least the LE Client specified in the REQUESTER-LECID field. If the LECID of an LE\_FLUSH\_RESPONSE frame is unknown (i.e., does not match the LECID of any LE Client), an LE Server MUST forward the frame to at least all LE Clients that successfully joined as proxy LE Clients.

#### 10.1.1.8 BUS Path Switching Procedures

If the BUS switches between a Multicast Send VCC and a Multicast Forward VCC forwarding paths for data frames to a given LAN Destination, then the BUS MUST attempt to ensure in order data frame delivery by employing procedures specified for LE Clients in this chapter (i.e., Flush Protocol and/or maximum Path Switching Delay).

#### 10.1.1.9 Validating ELAN-ID

An LE Client MUST ignore an LE\_FLUSH\_REQUEST received on an LLC multiplexed Data Direct VCC if the ELAN-ID of the received frame does not match the LE Client's variable C31.

#### 10.1.1.10 LLC Translation

An LE Client MUST delete the 12-octet LLC multiplexed header from an LE\_FLUSH\_REQUEST received on an LLC-multiplexed Data Direct VCC when converting it to an LE\_FLUSH\_RESPONSE for transmission on the Control Direct VCC.

### 10.1.2 Optional Protocol

An LE Client MAY have multiple paths available to reach any given LAN Destination, for example, a Data Direct VCC and the Default Multicast Send VCC to the Broadcast and Unknown Server. In order to ensure that data frames sent to a given LAN Destination are delivered in the same order sent, an LE Client SHOULD perform the following flush message protocol whenever it switches data paths to reach that LAN Destination.

- NOTE: In this section, the words SHOULD, MUST, SHOULD NOT, and MUST NOT apply only to LE Clients that choose to implement the flush message protocol.

#### 10.1.2.1 Transaction ID in LE\_FLUSH\_REQUEST

The LE Client MUST send an LE\_FLUSH\_REQUEST on the old data VCC (either a Data Direct VCC or the Default Multicast Send VCC). This request MUST contain a Transaction ID not currently in use by the LE Client. (The Transaction ID MAY, for example, be a counter that is increased each time a new Transaction ID is needed.) It MUST also contain the requester's primary ATM address and an ATM address of the target LE Client to which the path is being switched.

#### 10.1.2.2 Target LAN Destination in LE\_FLUSH\_REQUEST

The LE Client MUST include a Target LAN Destination in an LE\_FLUSH\_REQUEST sent to the BUS on the Default Multicast Send VCC. The LE Client MAY include a Target LAN Destination in an LE\_FLUSH\_REQUEST sent on a Data Direct VCC.

### 10.1.2.3 Multiplexed Data Direct VCCs

If transmitted on an LLC multiplexed Data Direct VCC, the LE\_FLUSH\_REQUEST MUST be in the LLC multiplexed control frame format, and the LE Client's ELAN-ID variable C31 MUST be placed in the LLC multiplexed header. If transmitted on a non multiplexed Data Direct VCC, the LE\_FLUSH\_REQUEST MUST be in the non multiplexed control frame format

### 10.1.2.4 Changing Data Paths

Until the LE Client originating the LE\_FLUSH\_REQUEST receives the LE\_FLUSH\_RESPONSE with a matching Transaction ID, or until it times out (time C21) waiting for that response, it MUST NOT send any data frames over the old data path destined for the same LAN Destination that prompted sending the LE\_FLUSH\_REQUEST.

### 10.1.2.5 Discarding or Holding Data Frames

Data frames destined for a LAN Destination that is awaiting an LE\_FLUSH\_RESPONSE MAY be discarded, or MAY be held by the LE Client until the LE\_FLUSH\_RESPONSE is received or timed out.

### 10.1.2.6 Data Frame Handling

If an LE Client times out an LE\_FLUSH\_REQUEST, and it is holding data frames awaiting the request's LE\_FLUSH\_RESPONSE, those held frames MUST either be discarded or sent down the old data path. The LE Client MAY then send another LE\_FLUSH\_REQUEST with a new Transaction ID. If it does so, it MUST ignore any LE\_FLUSH\_RESPONSE received with the old Transaction ID. Note that limitations on the frequency of sending unicast frames to the BUS may require some held frames to be discarded.

### 10.1.2.7 Transmitting Held Frames

Once the LE\_FLUSH\_RESPONSE is received, the LE Client MUST transmit any held data frames on the new data path before transmitting any further frames on the new path.

### 10.1.2.8 Switching Over Paths Without Flush

Regardless of the provisions of the rest of Section 10.1, when switching from the old path to a new path, if an LE Client has not transmitted a data frame to a particular LAN Destination via the old path for a period of time greater than or equal to the C22 Path Switching Delay, then it MAY start using the new path without employing the Flush protocol.

## 10.1.3 Multicast

The LE\_FLUSH protocol can not be applied to ensure the ordered delivery of multicast frames when switching paths. The LE Client SHOULD NOT transmit a frame with a given multicast address over a new path until time C22 Path Switching Delay has expired since the LE Client transmitted a frame with the same multicast address. Data frames destined for a multicast LAN Destination that are awaiting expiry of the C22 Path Switching Delay timer MAY be discarded or MAY be held until the timer expires.

## 10.2 Flush Frames

Flush messages are used for ensuring the in-order delivery of data frames. They are described in Table 39.

**Table 39. Flush Frame Format**

Offset non muxed	Offset LLC muxed	Size	Name	Function
not present	0	3	LLC	Logical Link Control = X"AAAA03"
not present	3	3	OUI	Organizational Unit Indicator = X"00A03E"
not present	6	2	FRAME-TYPE	Type of frame, X"000C" for Ethernet format or X"000D" for Token Ring format LANE LLC-multiplexed control frames
Not present	8	4	ELAN-ID	ID of Emulated LAN to which this frame belongs.
0	12	2	MARKER	Control Frame = X"FF00"
2	14	1	PROTOCOL	ATM LAN Emulation protocol = X"01"
3	15	1	VERSION	ATM LAN Emulation protocol version = X"01"
4	16	2	OP-CODE	Type of request: X"0007" LE_FLUSH_REQUEST X"0107" LE_FLUSH_RESPONSE
6	18	2	STATUS	Always X"0000" in requests. In Responses: See Table 18 for a list of values.
8	20	4	TRANSACTION-ID	Arbitrary value supplied by the requester and returned by the responder.
12	24	2	REQUESTER-LECID	LECID of LE Client issuing the flush request.
14	26	2	FLAGS	Always 0 sending, ignored on receipt.
16	28	8	SOURCE-LAN-DESTINATION	Always X"00" when sent, ignored on receipt.
24	36	8	TARGET-LAN-DESTINATION	Destination unicast MAC address or next Route Descriptor for which Flush is being requested, not required in response.  May be X"00" for flush requests over a Data Direct VCC.
32	44	20	SOURCE-ATM-ADDRESS	Primary ATM address of originator of flush request.

52	64	4	RESERVED	Always X"00" when sent, ignored on receipt.
56	68	20	TARGET-ATM-ADDRESS	ATM address, either LLC-multiplexed or non-multiplexed, of LE Client to which flush request is directed.
76	88	32	RESERVED	Always X"00" when sent, ignored on receipt.



## 11. Termination Protocol and Procedures

Procedures to be used by an LE Client and an LE Server when terminating an LE Client's emulated LAN membership are defined to ensure that clients may be effectively managed by the LAN Emulation service.

### 11.1 Termination - LE Client View

#### 11.1.1 Releasing Control and Multicast Data VCCs

Whenever the preceding sections on Protocols and Procedures indicate that an LE Client terminate a procedure or an LE Client's connection to the emulated LAN, with the exceptions defined in the paragraphs below, non-multiplexed SVCs associated with this LE Client, all Control VCCs and all Multicast Send/Multicast Forward VCCs, **MUST** be released and any LLC-multiplexed Data Direct VCCs **MUST** no longer be used. These call release operations are supported by UNI signalling protocols.

#### 11.1.2 Shared VCCs

An LE Client **MUST NOT** release LLC-multiplexed VCCs shared with another LE Client when it terminates. Except as defined below, or unless an LLC-multiplexed VCC is shared with some non-LANE protocol, when multiple LE Clients sharing a VCC are terminated, the last LE Client to terminate **MUST** release the VCCs.

#### 11.1.3 Releasing Data Direct VCCs

Whenever the procedures of Section 11.1.1 occur, an LE Client **SHOULD** discontinue use of any Data Direct VCCs. The LE Client **SHOULD**, but is not required to, flush any dynamically-learned entries from its LE\_ARP cache.

#### 11.1.4 LE Client Returns to Configuration Phase

If an LE Client's membership is terminated by an explicit server release of Control Direct or Control Distribute VCCs signalled with UNI Reason Code (for example UNI 3.0/3.1 "Normal, Unspecified" - Cause 31, or UNI 3.1 "Normal Call Clearing, Cause 16"), the client **MUST** perform the functions described in Section 11.1.1 and return to the Initial State. Until the ability to reverify LE\_ARP cache bindings is regained, an LE Client **MAY** indefinitely continue to use any pre-existing LE\_ARP cache entries over Data Direct VCCs established before the termination. Such use is not subject to the normal C17/C18 aging time-outs.

#### 11.1.5 Re-establishment of LES Connectivity

When an LE Client regains connectivity to a LES after a failure and it is determined that it is now a member of a different ELAN as previously, it **MUST** flush all LE\_ARP cache entries and release all Data Direct VCCs. If it is determined that it is still a member of the same ELAN as previously, it **MUST** reverify all LE\_ARP cache entries according to the current C17/C18 timer periods and flush any cache entries found to be invalid. ELAN membership may be determined by comparing old and new values for C31 ELAN ID, or if C31 ELAN ID was not returned in the LE\_JOIN\_RESPONSE, C5 ELAN Name.

### 11.2 Termination - LE Service View (LES or BUS)

#### 11.2.1 LE Server and BUS Actions

Whenever the preceding sections on Protocols and Procedures indicate that the LE Service terminates an LE Client's membership in the emulated LAN, with the exceptions defined below, all VCCs associated with this LE Client **MUST** be released with the UNI Reason Code (for example UNI 3.0/3.1 "Normal, Unspecified" - Cause 31, or UNI 3.1 "Normal Call Clearing, Cause 16"). The LE Server **MUST** clear any registered LAN Destinations and cached address bindings associated with that LE Client.

### **11.2.2 VCC Re-establishment**

An LE Server or BUS MUST NOT attempt to re-establish the VCCs to any LE Client after they have been released for any reason. It is the LE Client's responsibility to reinitiate its connection to the emulated LAN.

### **11.2.3 LE Client May Have Service Refused or Terminated**

The LAN Emulation Service MAY terminate and/or refuse service to any LE Client whose behavior violates the normative rules in the LAN Emulation specification.

## 12. Usage of ATM Addresses

In order to support both non-multiplexed and LLC-multiplexed VCC environments, ATM LAN Emulation components must be able to reliably associate incoming LAN Emulation frames with particular emulated LANs and functions within each emulated LAN.

In general, there are three ways of identifying such associations.

1. Explicit SVC identification. The SVC SETUP message identifies the emulated LAN and the usage of all frames carried on a VCC.
2. Implicit identification. ATM addresses of LE components are allocated in such a way that they help to identify emulated LANs and LAN functions.
3. Per-frame identification. Each frame sent over the VCC carries some means of identification.

LANE v1 uses only the first two of these techniques. In LANE v1, call setup using UNI signalling procedures MUST indicate whether LAN Emulation SVCs carry LE Control traffic, LE Multicast Ethernet/IEEE 802.3 traffic, LE Multicast IEEE 802.5 traffic, LE Data Direct Ethernet/IEEE 802.3 traffic, or LE Data Direct IEEE 802.5 traffic (Section 3.3.3.8.6). In addition, LE Clients, LE Servers, and Broadcast and Unknown Servers rely upon implicit identification to direct SVCs to the proper LAN Emulation component. In LANE v1, all frames carried on a particular VCC are destined for one particular component of one particular ELAN.

LANE v2 provides a third means of frame identification. The call setup parameters for LANE LLC-multiplexed connections do not specify the usage of the VCC; a VCC may even carry both LANE and non-LANE frames. LANE components (and non-LANE components) may share the same ATM addresses. In this case, the first few octets of every frame carried on the VCC are encoded using the IEEE 802.2 Logical Link Control protocol [8]. An eight-octet LLC/SNAP sequence distinguishes LANE frames from non-LANE frames. A four-octet ELAN-ID following the LLC/SNAP sequence identifies to which ELAN the frame belongs. After that, the normal LANE v1 format is able to distinguish between control and data frames.

For the purposes of the normative statements below, a LAN Emulation component is defined to be any of the following: a LAN Emulation Client, a LAN Emulation Server, a Broadcast and Unknown Server, or a LAN Emulation Configuration Server. For all but the LAN Emulation Configuration Server, each instance of the component on a different Emulated LAN is considered a separate component. For example, a bridge attached to three Emulated LANs is considered to have three LE Clients, not one LE Client attached to three ELANs, even if those three LE Clients use the same ATM address and share the same VCCs.

### 12.1 ATM Address Uses Summary

LAN Emulation components MUST adhere to Table 40 when assigning and utilizing ATM addresses. In the first part of Table 40, the ATM addresses, **X**, **x**, **x'**, **S**, **B**, and **C** are defined. These, plus other addresses marked "any", are summarized in the second part of Table 40. Except for addresses **B** and **S** (which may or may not be equal to each other), all of the ATM addresses **X**, **S**, **C** and **B** MUST be distinct.

Table 40. ATM Address Uses

Definition	Name
A particular LE Client's primary ATM address	<b>X</b>
Any ATM address belonging only to LE Client <b>X</b>	<b>x</b>
<b>x</b> , or ATM address shared with any LE Client co-resident with <b>X</b> on same UNI	<b>x'</b>
LECS's ATM address as seen by LE Client <b>X</b>	<b>C</b>
A particular BUS's ATM address (maybe == <b>S</b> )	<b>B</b>
A particular LES's ATM address	<b>S</b>
<b>Usage</b>	<b>ATM Address</b>

Configuration Direct VCC calling party	any
Configuration Direct VCC called party	C
SOURCE-ATM-ADDRESS in LE_CONFIGURE_REQUEST for LE Client X	X
LES's ATM address in LE_CONFIGURE_RESPONSE to v1 LE Client X	S
Control Direct VCC calling party	X
Control Direct VCC called party	S
SOURCE-ATM-ADDRESS in LE_JOIN_REQUEST for LE Client X	X
Control Distribute VCC calling party	S
Control Distribute VCC called party	X
LE Client non-multiplexed ATM address in LE_REGISTER_REQUEST for unicast LAN Destination	x
LE Client LLC-multiplexed ATM address in LE_REGISTER_REQUEST for unicast LAN Destination	None or x'
LE Client non-multiplexed ATM address in LE_REGISTER_REQUEST for multicast LAN Destination	X
LE Client LLC-multiplexed ATM address in LE_REGISTER_REQUEST for multicast LAN Destination	None
BUS's ATM address in LE_ARP_RESPONSE to LE Client X for all ones MAC address	B
Default Multicast Send VCC calling party	X
Default Multicast Send VCC called party	B
BUS's ATM address in LE_ARP_RESPONSE to LE Client X for multicast MAC address	Any*
Multicast Send VCC calling party	X
Multicast Send VCC called party	Any*
Multicast Forward VCC calling party	Any*
Multicast Forward VCC called party	X
LE Client non-multiplexed ATM address in LE_ARP_RESPONSE sent by LE Client X	x
LE Client LLC-multiplexed ATM address in LE_ARP_RESPONSE sent by LE Client X	None or x'

\* This address can be checked as being valid by using the LE\_VERIFY protocol.

## 12.2 LE Client ATM Addresses

### 12.2.1 Primary ATM Address

An operational LE Client MUST have a primary ATM address, and MAY have other ATM addresses.

### 12.2.2 Use of Primary Address

An LE Client **MUST** use its primary ATM address for establishing a Control Direct VCC, for establishing Multicast Send VCCs, and as the SOURCE-ATM-ADDRESS in its LE\_JOIN\_REQUEST control frames. An LE Client **MUST NOT** change its primary ATM address without terminating its connection to the emulated LAN.<sup>26</sup>

### 12.2.3 Unique ATM Addresses

Any ATM address supplied by an operational LE Client in the SOURCE-ATM-ADDRESS field of an LE\_ARP\_REQUEST or in the TARGET-ATM-ADDRESS field of an LE\_ARP\_RESPONSE **MUST** be unique to that LE Client. None of these ATM addresses may be shared with any other LAN Emulation component, even if two LAN Emulation components are co-located and share the use of a UNI. The LE Client can therefore associate an incoming non-multiplexed LAN Emulation SVC with the proper ELAN and LE Client on the basis of the Called Party Number.

### 12.2.4 Shared ATM Addresses

An ATM address supplied by an operational LE Client in the LLC-Muxed ATM Address TLV of an LE\_ARP\_RESPONSE **MUST** be unique to the set of LE Clients sharing Data Direct VCCs. The LE Client **MUST** then use the ELAN-ID of incoming frames to associate each frame with the ELAN and LE Client. This implies that multiple LE Clients on the same ELAN cannot share the same LLC-multiplexed ATM address.

## 12.3 LE Server ATM Addresses

### 12.3.1 ATM Address Required

An operational LE Server **MUST** have exactly one ATM address.

### 12.3.2 Sharing ATM Address

An LE Server **MAY** share an ATM address with a Broadcast and Unknown Server. An LE Server **MUST NOT** share an ATM address with another LE Server for a different ELAN on the same UNI.

### 12.3.3 When Sharing ATM Addresses is not valid

An operational LE Server **MUST NOT** use the same ATM address as any other LAN Emulation component other than a BUS.

## 12.4 Broadcast and Unknown Server ATM Addresses

### 12.4.1 BUS ATM Address Required

An operational Broadcast and Unknown Server **MUST** have at least one ATM address, and **MAY** have more.

### 12.4.2 Sharing an ATM Address

A Broadcast and Unknown Server **MAY** share an ATM address with an LE Server or an LE Configuration Server. A Broadcast and Unknown Server **MUST NOT** share an ATM address with another Broadcast and Unknown Server on the same UNI.

---

<sup>26</sup> After a client leaves an emulated LAN, other clients **CAN** remember its ATM addresses in their LE\_ARP caches until their cache entries time out (which might take several minutes). Hosts that want to reassign ATM addresses to a different LAN Emulation component ought to take precautions to prevent the establishment of Data Direct VCCs which cross two emulated LANs.

### 12.4.3 When Sharing ATM Addresses is not valid

An operational Broadcast and Unknown Server **MUST NOT** share an ATM address with any LAN Emulation component other than a LES for the same emulated LAN, even if two LAN Emulation components are co-located and share the use of a UNI. In particular, two Broadcast and Unknown Servers for different emulated LANs **MUST NOT** share an ATM address.

An operational Broadcast and Unknown Server **MUST NOT** use the same ATM address as any other LAN Emulation component (other than a LES for the same emulated LAN) for a Multicast Send or Multicast Forward VCCs, even if that other LAN Emulation component is co-located and shares the use of Broadcast and Unknown Server's UNI.

## 12.5 LE Configuration Server ATM Addresses

### 12.5.1 ATM Address Required

An operational LE Configuration Server **MUST** have at least one ATM address, and **MAY** have more.

Note: Even if ILMI Address Registration of an LECS address fails, particularly for the well known address, the network might nonetheless correctly route calls to the LECS. For better interoperability, the LECS **SHOULD** therefore accept calls to the well known address if it tried and failed to register that address using ILMI.

### 12.5.2 Sharing an ATM Address

Several operational LE Configuration Servers **MAY** share a "well-known" ATM address, but any one LE Client is only aware of a single instance: this is ensured by the assumed definition of a "well-known" address. Note that it is highly desirable for the LE Configuration Service to be set up in such a way that LE Clients who tear down and re-establish Configuration Direct SVCs see consistent information. How this is accomplished is beyond the scope of this specification. An LECS **MAY** share an ATM address with a BUS.

### 12.5.3 When Sharing ATM Address not valid

An operational LE Configuration Server **MUST NOT** share an ATM address with an LE Client or LE Server.

## Annex A LAN Emulation Control Frame TLVs

This annex provides the specifications for all of the TLVs which are defined for LANE. The Version column indicates whether the TLV is defined for LANE v1 or LANE v2 LE Clients. If the TLV is defined for LANE v1, the TLV is valid for LANE v1 and LANE v2 LE Clients, unless otherwise noted. Other TLVs are specified in other Interoperability Agreements and therefore are not defined in this document.

Table 41. LAN Emulation Control Frame TLVs

Item	Type	Len	Description	Version
Max-Cumulative-Control-Time-out	00-A0-3E-01	2	<b>C7 Control Time-out</b> /in seconds	LANE v1
Max-Unknown-Frame-Count	00-A0-3E-02	2	<b>C10 Maximum Unknown Frame Count</b>	LANE v1
Max-Unknown-Frame-Time	00-A0-3E-03	2	<b>C11 Maximum Unknown Frame Time</b> /in seconds	LANE v1
VCC-Time-out-Period	00-A0-3E-04	4	<b>C12</b> /in seconds	LANE v1
Maximum-Retry-Count	00-A0-3E-05	2	<b>C13 Maximum Retry Count</b>	LANE v1
Aging-Time	00-A0-3E-06	4	<b>C17</b> /in seconds	LANE v1
Forward-Delay-Time	00-A0-3E-07	2	<b>C18</b> /in seconds	LANE v1
Expected-LE_ARP-Response Time	00-A0-3E-08	2	<b>C20</b> /in seconds	LANE v1
Flush-Time-out	00-A0-3E-09	2	<b>C21</b> /in seconds	LANE v1
Path-Switching-Delay	00-A0-3E-0A	2	<b>C22</b> /in seconds	LANE v1
Local-Segment-ID	00-A0-3E-0B	2	<b>C23</b> Local Segment ID. Twelve bit segment ID of the emulated LAN in the binary format 0000SSSSSSSSSSSS.	LANE v1
Default-Mcast-Send-VCC-Type	00-A0-3E-0C	2	<b>C24:</b> X'0000' Best Effort: LE Client should set the BE flag. Peak Cell Rates should be line rate. X'0003' Variable: LE Client should provide a Peak and a Sustained Cell Rate (see below). X'0004' Constant: LE Client should provide a Peak Cell Rate (see below).	LANE v1
Default-Mcast-Send-VCC-AvgRate	00-A0-3E-0D	4	<b>C25</b> /in cells per second	LANE v1
Default-Mcast-Send-VCC-PeakRate	00-A0-3E-0E	4	<b>C26</b> /in cells per second	LANE v1
Connection-Completion-Timer	00-A0-3E-0F	2	<b>C28</b> /in seconds	LANE v1
Config-Frag-Info	00-A0-3E-10	0 - 255	INDEX - MUST be used only with LE_CONFIGURE frames. Use with other frames is undefined.	LANE v2

Layer-3-Address	00-A0-3E-11	Variable	Layer 3 address of LE Client encoded Address according to [22]. More than one Layer 3 Address TLV may be included in an LE_CONFIGURE_REQUEST. A non-normative description of the ISO 10747 [22] format is shown in Appendix E.	LANE v2
ELAN-ID	00-A0-3E-12	4	ELAN-ID of the ELAN the LE Client should join	LANE v2
Service-Category	00-A0-3E-13	2	Bitfield: 0 == 1 if rt-VBR is supported, 0 otherwise. 1 == 1 if nrt-VBR is supported, 0 otherwise. 2 == 1 if ABR is supported, 0 otherwise. 3 == 1 if CBR is supported, 0 otherwise. 4 - 15 undefined (for future use). Must be 0 on send, ignored on receipt.	LANE V2
LLC-Muxed-ATM-Address	00-A0-3E-2B	20	ATM Address suitable for LLC-multiplexed VCCs. Serves the same function as the non-multiplexed ATM address in the SOURCE-ATM-ADDRESS field in a request frame, and as the TARGET-ATM-ADDRESS in a response frame.	LANE v2
X5-Adjustment	00-A0-3E-2C	0	Modifies the meaning of both of the values X"01" and X"02" in the MAXMUM-FRAME-SIZE field to mean 1580/1592 octets. MUST NOT be present if the "V2 Capable" FLAGS bit is not set.	LANE v2
Preferred-LES	00-A0-3E-2D	20	The ATM address of the Preferred LE Server. This TLV is returned by the LECS and included in the LE_JOIN request.	LANE v2

where 00-A0-3E is the ATM Forum OUI.



# Annex B Connection Setup Procedure

The following protocol is used to complete the establishment of point-to-point SVCs. It provides a mechanism such that the called party can determine when the connection has been established end-to-end.

## B.1 Protocol Overview

When a call is being set up, the called party must initialize the local VCC and SAR and be ready to receive frames on the newly created VCC before it sends the CONNECT message. A called party must also assume that the call establishment is complete as soon as a CONNECT message is sent, not upon receipt of CONNECT ACK message.

Thus, the calling party should be able to assume that it can transmit frames after it has received the CONNECT message.

Since the CONNECT\_ACK message which is received by the called party may be generated by its local switch and is not an end-to-end indication from the the calling party, it may be received by the called party before the calling party has received its CONNECT message. The calling part can only set itself up to receive frames on the VCC after it receives a CONNECT message which indicates the allocation of the VPI/VCI numbers. Thus, there is no guarantee for the called party that its initial data will be received by the calling party until it receives some end-to-end indication.

So that the called party can initiate data transfer on a VCC, the ATM layer call establishment procedures are augmented by an additional protocol.

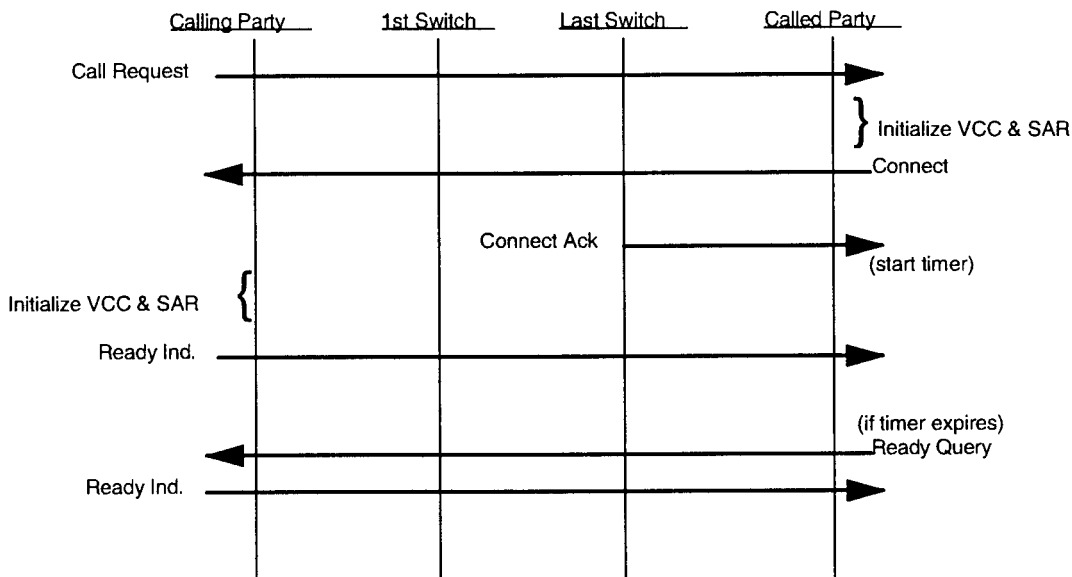

Figure 9. Call Establishment: Ready Indicate/Query

In Figure 9, the SETUP, CONNECT, and CONNECT\_ACK messages are the SVC call setup messages [5,17]. The READY\_IND, and READY\_QUERY messages are defined in this specification (See Annex B).

The calling party must send a READY\_IND message as soon as it is ready to receive frames on the newly established VCC. At that point, the calling party considers call establishment to be complete. The calling party may also send data as soon as it it ready to receive frames on the newly established VCC. Data may be sent before or after the sending of the READY\_IND.

Of course, it is possible that the READY\_IND message may be lost. To recover, the called party is responsible for timing the arrival of the READY\_IND message. If the timer expires, the called party sends data or READY\_QUERY message on the VCC. Either party shall always respond to receipt of a READY\_QUERY message on an active VCC by transmitting a READY\_IND message.

## B.2 READY\_IND/READY\_QUERY Protocol

The following protocol is used for all point-to-point, non-multiplexed Data Direct VCCs and all point-to-point LLC-multiplexed Data Direct VCCs established by LE Clients. When an LE Client starts using a shared LLC-

multiplexed VCC set up by another protocol entity, it should determine locally whether the VCC is up. It **MUST** however, reply to any **READY\_QUERY** frames directed to it. When multiple LE Clients are using the same LLC-multiplexed VCC, the first LE Client to use the VCC **MUST** use the **READY** protocol and the other LE Clients should determine the VCC state from the first LE Client.

### B.2.1 Calling Client Action on Receiving **CONNECT** Message

An entity that receives a **CONNECT** message for a requested VCC **MUST** issue a **READY\_IND** message as soon as it is ready to accept frames on that VCC. It then **MAY** also send data or flush frames. It **MUST NOT** send any frames before it is ready to accept frames. Data, Control or Flush frames **MAY** be sent before the **READY\_IND** message on the same VCC.

### B.2.2 Called Client Terminates **C28**

If the called entity implements time-out **C28**, then it **MUST** terminate time-out **C28** upon receipt of a **READY\_IND** frame. The called LE Client **MAY** also terminate time-out **C28** upon receipt of any valid frame on the VCC. If the called entity transmits any data or control frames before receiving the **READY\_IND** or valid data, then this data may be discarded by the network.

### B.2.3 Called Client Timer **C28** Expires

If time-out **C28** expires, the entity **MAY** transmit data or a **READY\_QUERY** frame. It **MAY** re-establish time-out **C28**, and repeat this as desired.

### B.2.4 **READY\_IND** Response to **READY\_QUERY**

An entity receiving a **READY\_QUERY** frame on any operational VCC **MUST** reply with a **READY\_IND** frame.

### B.2.5 Ready Frame Format

Table 42. Ready Frame Format

Offset non muxed	Offset LLC muxed	Size	Name	Function
not present	0	3	LLC	Logical Link Control = X"AAAA03"
not present	3	3	OUI	Organizational Unit Indicator = X"00A03E"
not present	6	2	FRAME-TYPE	Type of frame, X"000E" for LANE LLC-multiplexed <b>READY_IND</b> and <b>READY_QUERY</b> control frames.
not present	8	4	ELAN-ID	ID of Emulated LAN to which this frame belongs.
0	12	2	MARKER	Control Frame = X"FF00"
2	14	1	PROTOCOL	ATM LAN Emulation Protocol=X"01"
3	15	1	VERSION	ATM LAN Emulation Protocol=X"01"
4	16	2	OP-CODE	X"0003": <b>READY_QUERY</b> X"0103": <b>READY_IND</b>

## Appendix A State Machine Description of LAN Emulation

This appendix presents a state machine model of the LAN Emulation Client (LE Client).

The purpose of this appendix is to help ensure the correctness and completeness of the specification and to increase its clarity. This is important to assure interoperability at the LUNI interface between an LE Service from a particular vendor and LE Clients from any other vendor. This model should be viewed as a possible interpretation of the LAN Emulation specification. Note that some of the transitions are implementation dependent, either optional or determined by local policy.

Each state machine is modeled with a set of states and a set of transitions. Each transition interconnects a pair of states. The behavior of a state machines is based on events and actions: if an event happens when the machine is in a particular state, then the action is performed and a state transition takes place (potentially back to the same state). Events are either reception of a frame over a VCC, a command from the higher layer or timer expiration. An event triggers at most one transition. An event that is not specified in the state machine is ignored.

Each LE Client is modeled with a main state machine that starts from the LM\_LEC\_INITIALIZE.request higher layer command and establishes the Operational\_LEC state by going through the configuration, joining, and BUS communication phases.

A set of state machines, one per local LAN Destination, describes the registration process of each address. These machines apply only after the LE Client has completed the joining phase.

An additional set of state machines, one set per LAN Destination/QOS pair describes the establishment of valid LDs while in the Operational\_LEC state. Each of these "LD" machines establishes an operational LAN Destination (LD) by performing LE\_ARP, VCC setup, etc.

### A.1 The LE Client State Machines

The LE Client state machine is shown in Figure 10 and Figure 11. Each of the transitions is described in more detail below.

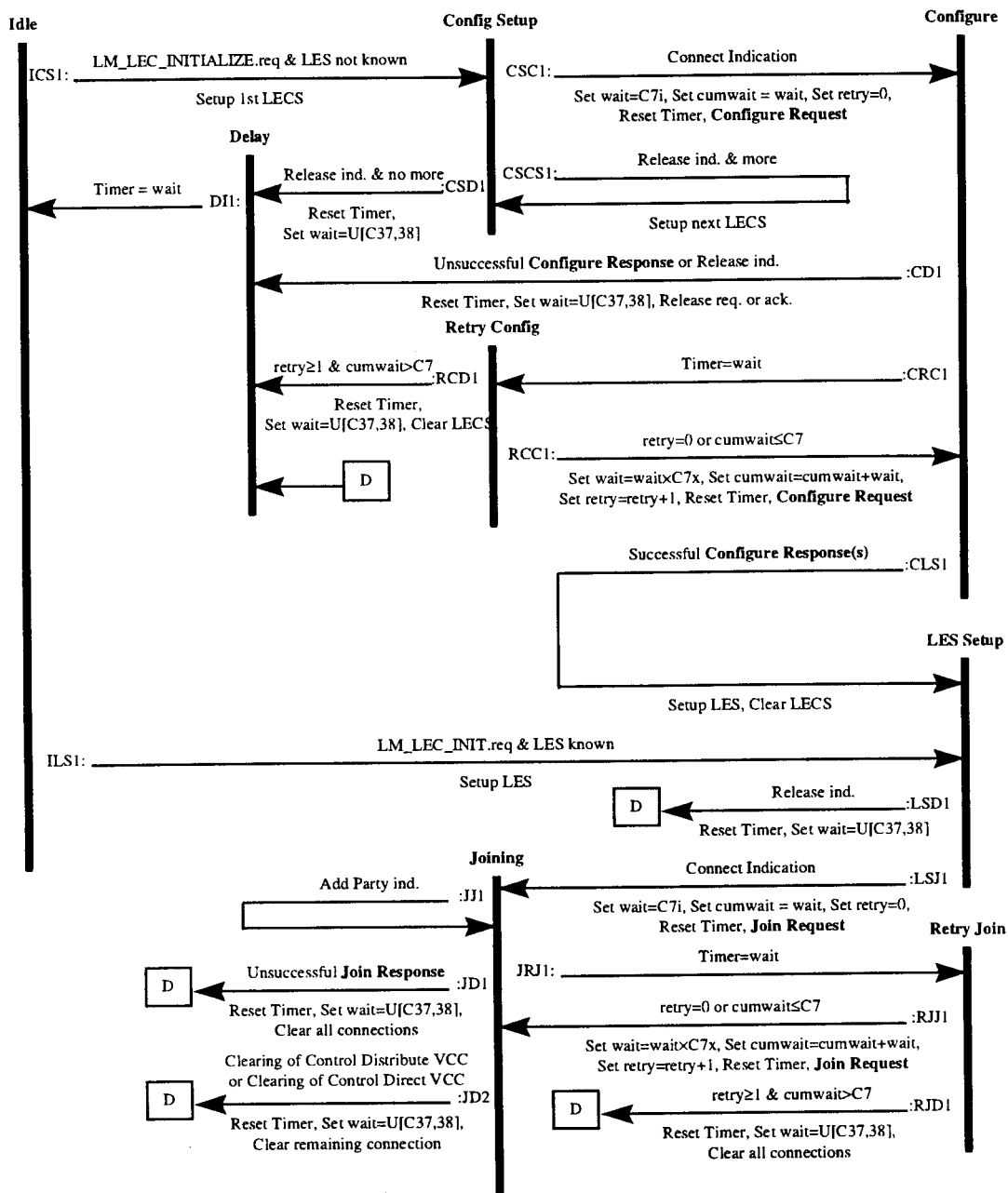

Figure 10. LE Client State Machine (Initialization)

ICSI: When the higher layer issues an LM\_LEC\_INITIALIZE.request to the LE Client, the LE Client may or may not know the ATM address of the LE Server. If the LE Client does not know the ATM address of the LE Server, then it tries to setup the Config VCC to an LECS, based on the first ATM address from the list of potential ATM addresses of LECSs. The LE Client obtains this list through interaction with ILMI (the interaction is not specified here). A well known ATM address of an LECS is also part of the list.

- CSCS1:** If an attempt to setup the Config VCC to the LECS fails and the LE Client has more ATM addresses of potential LECSs in its list, then the LE Client repeats the attempt to setup the Config VCC, to the next ATM address in the list.
- CSC1:** If the establishment of the Config VCC is successful, then the LE Client sends a Config request over the newly established Config VCC. This request includes at least the primary ATM address of the LE Client, and optionally more parameters. In addition, the time interval to wait before retrying the Config request is set to **C7i**. The variables *wait*, *cumwait*, and *retry* are set in order to control retrying of the Config request.
- CSD1:** If an attempt to setup the Config VCC to the LECS fails and the LE Client has no more ATM addresses of potential LECSs in its list, then the LE Client moves to the Delay state where it will wait a short time and then return to the Idle state.
- CLS1:** Upon receiving a successful Config response, the LE Client tries to set up Control Direct VCC to the LE Server, based on the ATM address from the Config response frame and it releases the Config VCC. Note that successful Config response includes the case where the CONFIG\_FRAG\_INFO TLV is used resulting in multiple Configuration Response messages being received.
- CD1:** If the Config response is unsuccessful, the LE Client releases the Configuration Direct VCC. If the Configuration Direct VCC is released by an entity other than the LE Client, the release is acknowledged by the LE Client. In either case, the LE Client moves to the Delay state where it will wait a short time and then return to the Idle state.
- CRC1:** If there is a timeout while waiting for the Config response, the state machine goes to the Retry Config state.
- RCC1:** If the LE Client has not retried the Config request at least once or the cumulative waiting time (*cumwait*) has not exceeded **C7**, the Config request is retried and the state machine moves to the Configure state. In addition, the number of retries is incremented, the timeout interval is increased, and the cumulative waiting time is updated.
- RCD1:** If the LE Client has retried the Config request and the cumulative waiting time exceeds **C7**, the Configuration Direct VCC is released and the state machine moves to the Idle state by passing through the Delay state.
- D11:** Once in the Delay state, the state machine waits for **C37** ms and then moves to the Idle state.
- ILS1:** If the LE Client knows the ATM address of the LE Server without consulting the LECS, then it tries to setup the Control Direct VCC. This causes the state machine to skip to the LES\_Setup state.
- LSJ1:** After receiving a Connect indication and completing the establishment of the Control Direct VCC, the LE Client sends a Join request with the proper parameters to the LE Server. In addition, the time interval to wait before retrying the Join request is set to **C7i**. The variables *wait*, *cumwait*, and *retry* are set in order to control retrying of the Join request.
- LSD1:** If the setup of the Control Direct VCC fails, the state machine moves to the Idle state by passing through the Delay state.
- JJ1:** The LE Client may receive an indication that the LE Server initiated the establishment of a Control Distribute VCC. In that case, the LE Client acknowledges the connection. Note that the first leaf of the point to multipoint Control Distribute VCC is performed with a Setup. Subsequent leafs are established with Add Party.
- JD1:** If an unsuccessful Join Response is received, the LE Client releases the Control Distribute VCC and the Control Direct VCC and returns to the Idle state by way of the Delay state.
- JD2:** If either of the Control VCCs is released, the LE Client returns to the Idle state by way of the Delay state.

- JRJ1: If there is a time-out while waiting for the Join response, the state machine goes to the Retry Join state.
- RJJ1: If the LE Client has not retried the Join request at least once or the cumulative waiting time (*cumwait*) has not exceeded C7, the Join request is retried and the state machine moves to the Joining state. In addition, the number of retries is incremented, the timeout interval is increased, and the cumulative waiting time is updated.
- RJD1: If the LE Client has retried the Join request and the cumulative waiting time exceeds C7, the control VCCs are released and the state machine moves to the Idle state by passing through the Delay state.

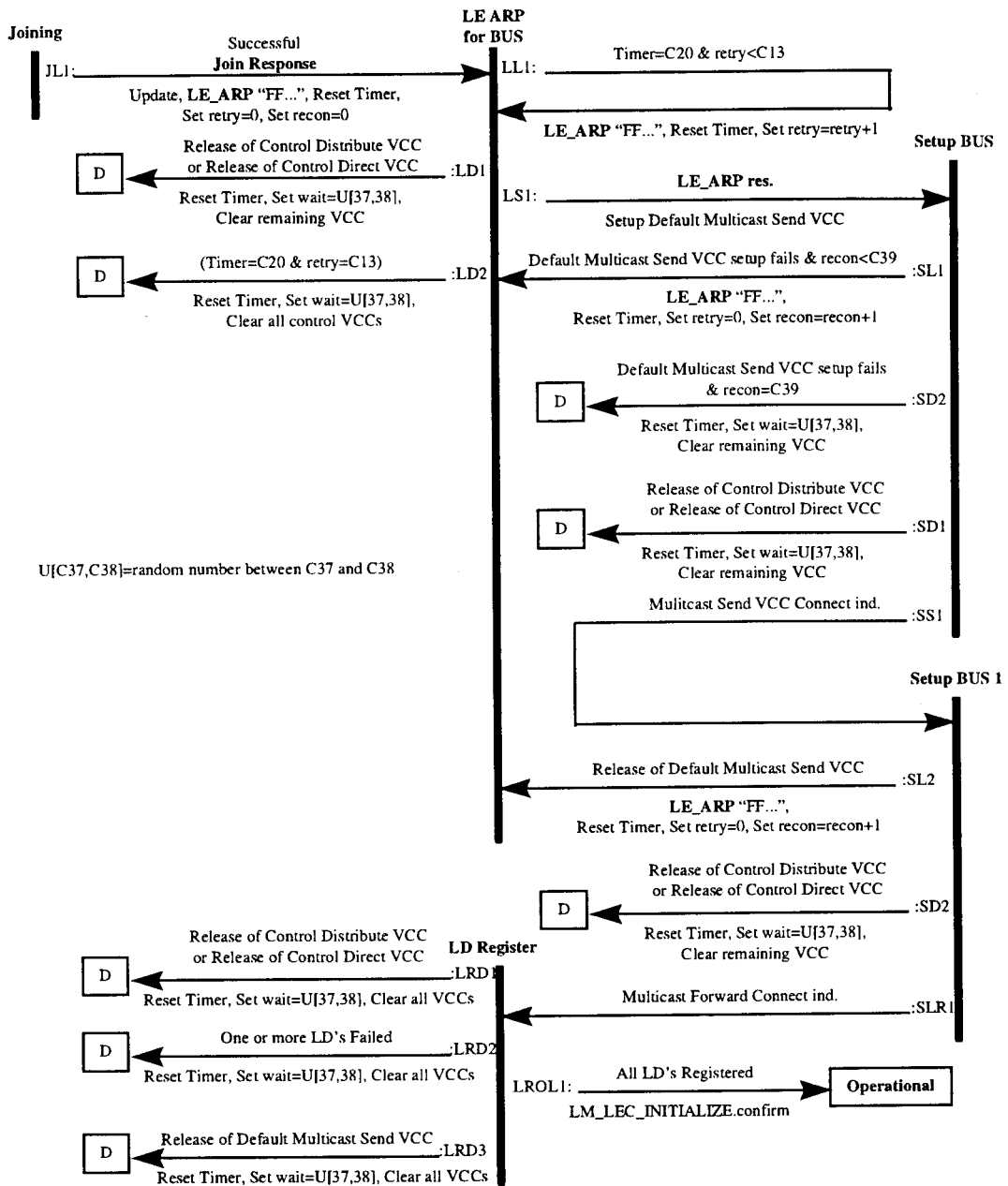

Figure 11. LE Client State Machine (Join, LE\_ARP)

- JL1:** If the LE Client receives a successful Join response, it issues an LE\_ARP for the BUS (an all "1" MAC address). The LE Client updates its parameters, in particular the LECID, based on the information in the Join response. The state machine resets the timer and initializes the *retry* and *recon* variables. (The *retry* variable counts the number of retries of the LE\_ARP for the BUS. The *recon* variable counts the number of retries to setup the Default Multicast Send VCC.
- LL1:** If the LE\_ARP response is not received in C20 seconds and there have been less than C13 retries, the LE Client retries the LE\_ARP for the BUS.
- LS1:** The LE Client receives the LE\_ARP response with the ATM address of the BUS. It uses that address to try and set up the Default Multicast Send VCC.

- LD1: If either of the Control VCCs is released, the LE Client returns to the Idle state by way of the Delay state.
- LD2: If C13 retries of the LE\_ARP for the BUS have failed, the LE Client returns to the Idle state by way of the Delay state.
- SL1: If the attempt to setup the Default Multicast Send VCC fails and there have been less than C39 retries, the LE Client increments the number of connection tries (*recon*), resets the timer, and sends another LE\_ARP for the BUS ATM address.
- SD1: If either of the Control VCCs is released, the LE Client returns to the Idle state by way of the Delay state.
- SD2: If the attempt to setup the Default Multicast Send VCC fails and there have been C39 retries, the LE Client returns to the Idle state by way of the Delay state.
- SS1: The LE Client receives a Connect indication and completes the establishment of the Default Multicast Send VCC to the BUS.
- SL2: If the Default Multicast Send VCC is cleared (before the first Multicast Forward is established), the LE Client restarts the LE\_ARP for the BUS process but without resetting the count of connection retries (*recon*).
- SD2: If either of the Control VCCs is released, the LE Client returns to the Idle state by way of the Delay state.
- SLR1: The LE Client receives an indication from the BUS to establish the first Multicast Forward VCC. In case of a point to multipoint VCC, the indication is a Setup for the first leaf and an Add Party for the subsequent ones. The LE Client acknowledges the establishment of the Multicast Forward VCC, and enters the LD Register state to wait until all local LAN Destinations are registered.
- LRD1: If either of the Control VCCs is released, the LE Client returns to the Idle state by way of the Delay state.
- LRD2: If one or more of the local LAN Destinations fails to be registered or unregistered (one or more of the Registration State Machines moves to the Failed state), the LE Client moves to the Idle state by way of the Delay state.
- LRD3: If the Default Multicast Send VCC is cleared, the LE Client returns to the Idle state by way of the Delay state.
- LORL1: When all of the local LAN Destinations are successfully registered, the LE Client enters the Operational LEC state and issues an LE\_LEC\_INITIALIZE.indication to the higher layer.



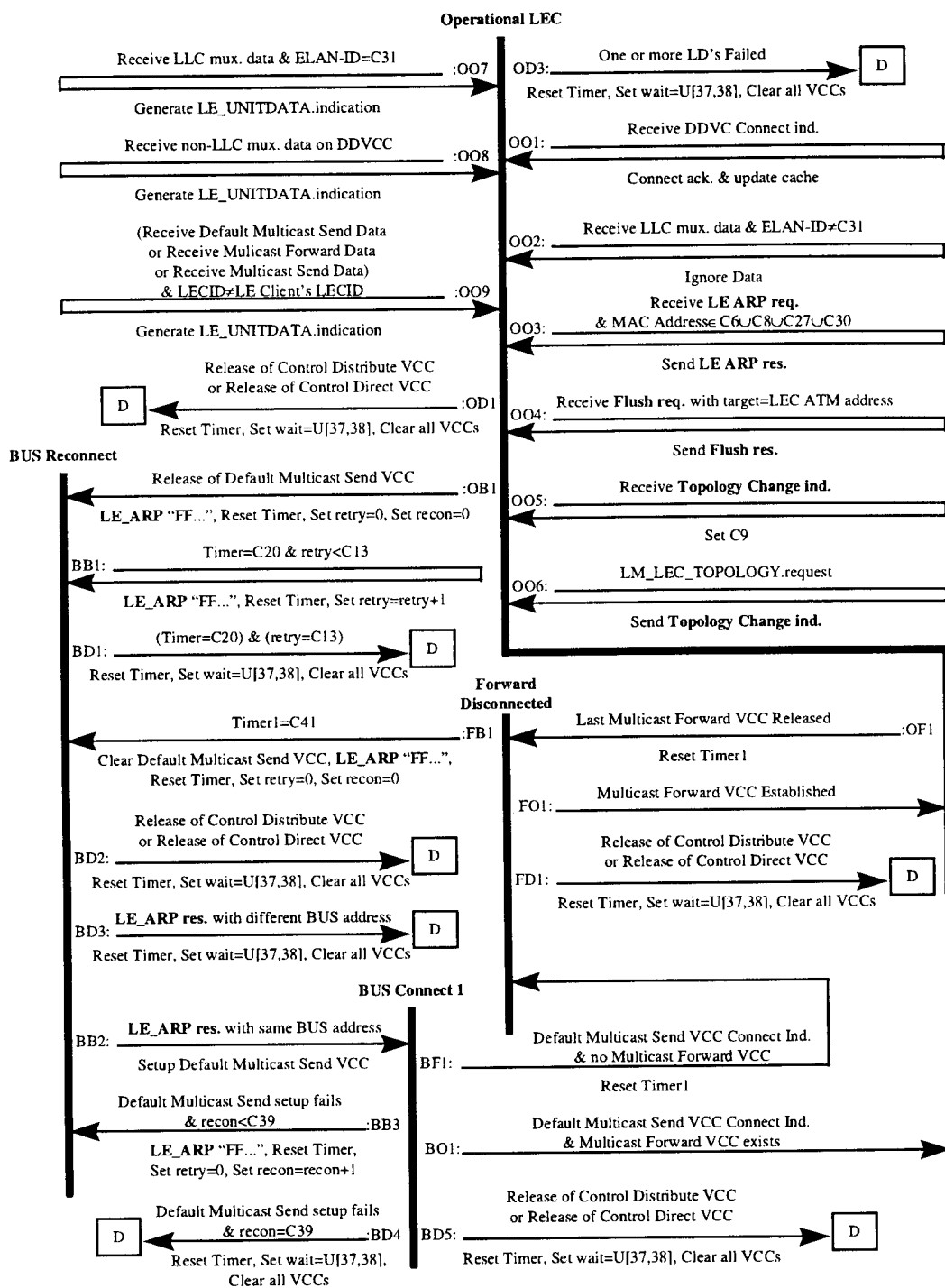

Figure 12. LE Client State Machine (Operational)

Note: In this state machine, all transitions to the Delay state ("D") show that all VCCs must be cleared. However an LE Client may optionally try to preserve Data Direct VCCs in the expectation that they can be re-verified after the LE Client initializes and becomes operational again. See Sections 11.1.4 and 11.1.5.

- BB1: If the LE\_ARP response is not received in C20 seconds and there have been less than C13 retries, the LE Client retries the LE\_ARP for the BUS.
- BB2: If the LE\_ARP response contains the same ATM address as the one used to setup the previous Default Multicast Send VCC, the LE Client tries to setup the Default Multicast Send to this ATM address.
- BB3: If the attempt to setup the Default Multicast Send VCC fails and there have been less than C39 retries, the LE Client increments the number of connection tries (*recon*), resets the timer, and sends another LE\_ARP for the BUS ATM address.
- BD1: If C13 retries of the LE\_ARP for the BUS have failed, the LE Client returns to the Idle state by way of the Delay State.
- BD2: If either of the Control VCCs is released, the LE Client returns to the Idle state by way of the Delay state.
- BD3: If the LE\_ARP response contains a different ATM address than the one used to setup the previous Default Multicast Send VCC, the LE Client returns to the Idle state by way of the Delay state.
- BD4: If the attempt to setup the Default Multicast Send VCC fails and there have been C39 retries, the LE Client returns to the Idle state by way of the Delay state.
- BD5: If either of the Control VCCs is released, the LE Client returns to the Idle state by way of the Delay state.
- BF1: If the LE Client receives a Connect indication and no Multicast Forward exists, the LE Client resets Timer1 and moves to the Forward Disconnected state to wait to see if a Multicast Forward will be reestablished.
- BO1: If the LE Client receives a Connect indication for the Default Multicast Send VCC and at least one Multicast Forward VCC exists, the LE Client returns to the Operational state.
- FB1: If Timer1 reaches C33 seconds, the LE Client clears the Default Multicast Send VCC, starts the LE\_ARP for the BUS process and resets the count of connection retries (*recon*).
- FD1: If either of the Control VCCs is released, the LE Client returns to the Idle state by way of the Delay state.
- FO1: If a Multicast Forward VCC is established, the LE Client returns to the Operational State.
- OB1: If the Default Multicast Send VCC is cleared, the LE Client starts the LE\_ARP for the BUS process and resets the count of connection retries (*recon*).
- OD1: If either of the Control VCCs is released, the LE Client returns to the Idle state by way of the Delay state.
- OD3: If any local LAN Destination fails to be registered or unregistered (one or more of the Registration State Machines moves to the Failed state), the LE Client moves to the Idle state by way of the Delay state.
- OF1: If the last Multicast Forward VCC, the LE Client resets Timer1 and moves to the Forward Disconnected state to wait to see if a Multicast Forward will be reestablished.
- OO1: The LE Client accepts incoming Direct VCCs from other LE Clients if resources are available. The LE Client records the Direct VCCs in its LAN Destination cache.
- OO2: If the LE Client receives data from an LLC multiplexed VCC and the ELAN-ID does not equal C31, the LE Client ignores the data.
- OO3: The LE Client responds to each of the LE\_ARP requests that include a MAC address that the LE Client had either registered or (if it joined as a Proxy) knows to be reachable (the address is in the union of C6, C8, C27, and C30). The response includes the ATM address that matches the MAC address.

- OO4: The LE Client responds to all the Flush requests that include one of its ATM addresses. The Flush request is received over any VCC and the Flush response is transmitted over the Control Direct VCC.
- OO5: The LE Client updates its cache aging threshold based on incoming Topology\_Change indications: if the flag is set, then the aging is accelerated, otherwise it is back to its default.
- OO6: An LE Client, that is an 802.1-D bridge, issues a Topology Change request following a higher layer LM\_LEC\_TOPOLOGY.request associated with sending a Topology Change BPDU.
- OO7: If the LE Client receives data on an LLC multiplexed DDVCC and the ELAN-ID matches, then it passes an LE\_UNITDATA.indication to the higher layer.
- OO8: If the LE Client receives data on a non-LLC multiplexed DDVCC, then it passes an LE\_UNITDATA.indication to the higher layer.
- OO9: If the LE Client receives data on either the Default Multicast Send VCC, a Multicast Forward VCC, or a Multicast Forward VCC and the LECID does not match that of the LE Client, then it passes an LE\_UNITDATA.indication to the higher layer.

## A.2 Registration State Machines

There is a Registration state machine for each LAN Destination. When an LE Client is in the Idle state, all Registration state machines are in the Unregistered state. During initialization, it is assumed that the higher layer issues an LE\_CONTROL primitive to register each local LAN Destination.

The Registration state machine is described in Figure 13. Each of the transitions is described in more details below.

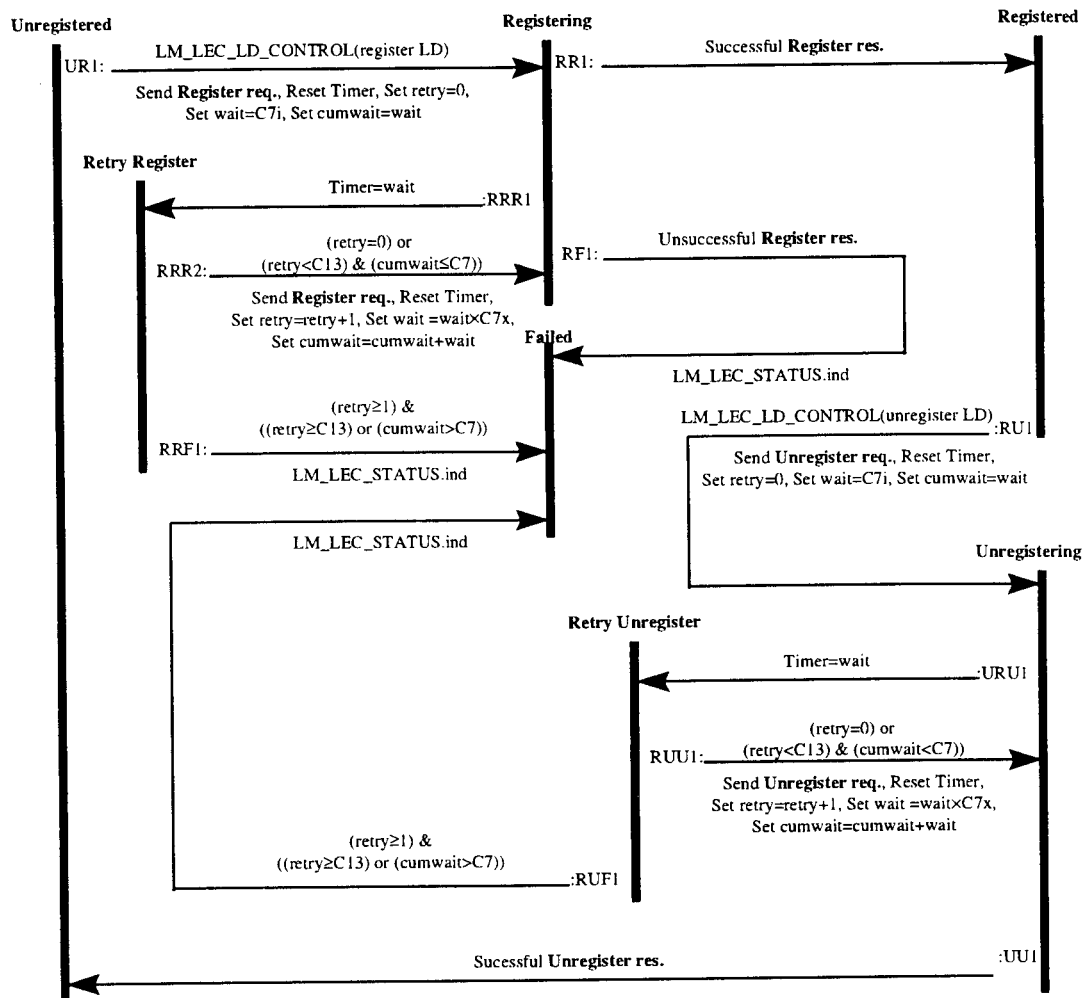

Figure 13. Registration State Machines

- UR1: Upon receiving an LM\_LEC\_LD\_CONTROL(register LD).req from the higher layer, the LE Client sends a Register request with the local LD. The LE Client also initializes the variables *wait*, *cumwait*, and *retry*.
- RR1: When the LE Client receives a successful **Register response**, with the respective LD, the LD becomes registered.
- RF1: If the **Register response** indicates failure, the Failed state is entered and the higher layer is notified of the failure with an LM\_LEC\_STATUS.indication. (Note that if the LE Client is a Proxy and the cause code is 6 for lack of resources, the LE Client may alternatively move the LD to C6 or C8 as appropriate and transition the state machine to Unregistered where it will remain. This avoids causing the LE Client to terminate its ELAN membership.)
- RRR1: When the Timer reaches the value *wait*, the Retry Register state is entered.
- RRR2: If the register has not been retried at least once or there have been less than C13 retries and the cumulative waiting time (*cumwait*) is less than or equal to C7, the register is retried and the Registering state is entered. In addition, the variables *wait*, *cumwait*, and *retry* are updated.
- RRF1: If the register has been retried at least once and there have been at least C13 retries or the cumulative waiting time (*cumwait*) is greater than C13, the register process has failed and the

Failed state is entered for this LD and the higher layer is notified of the failure with an LM\_LEC\_STATUS.indication.

- RUI: If the higher layer generates an LM\_LEC\_LD\_CONTROL(unregister LD), an **Unregister.request** is generated and the Unregistering state is entered. In addition, the variables *wait*, *cumwait*, and *retry* are initialized.
- URUI: When the Timer reaches the value *wait*, the Retry Unregister state is entered.
- UUI: When the LE Client receives a successful **Unregister response**, with the respective LD, the LD becomes unregistered.
- RUUI: If the unregister has not been retried at least once or there have been less than **C13** retries and the cumulative waiting time (*cumwait*) is less than or equal to **C7**, the unregister is retried and the Unregistering state is entered. In addition, the variables *wait*, *cumwait*, and *retry* are updated.
- RUF1: If the unregister has been retried at least once and there have been at least **C13** retries or the cumulative waiting time (*cumwait*) is greater than **C13**, the unregister process has failed and the Failed state is entered for this LD and the higher layer is notified of the failure with an LM\_LEC\_STATUS.indication.

### A.3 The LAN Destination State Machines

A LAN Destination state machine is invoked by each LE\_UNITDATA.request from the higher layer. This is done only if the LE Client state machine is in the Operational\_LEC state. To model the unicast process with QoS, a state machine is defined for each possible combination of LAN Destination and DDVC setup parameters. The DDVC setup parameters are identified by the qos\_handle parameter in the LE\_UNITDATA.request primitive (see Sec. 3.1.1.).

The LAN Destination state machine is described in Figure 14, Figure 15, and Figure 16.

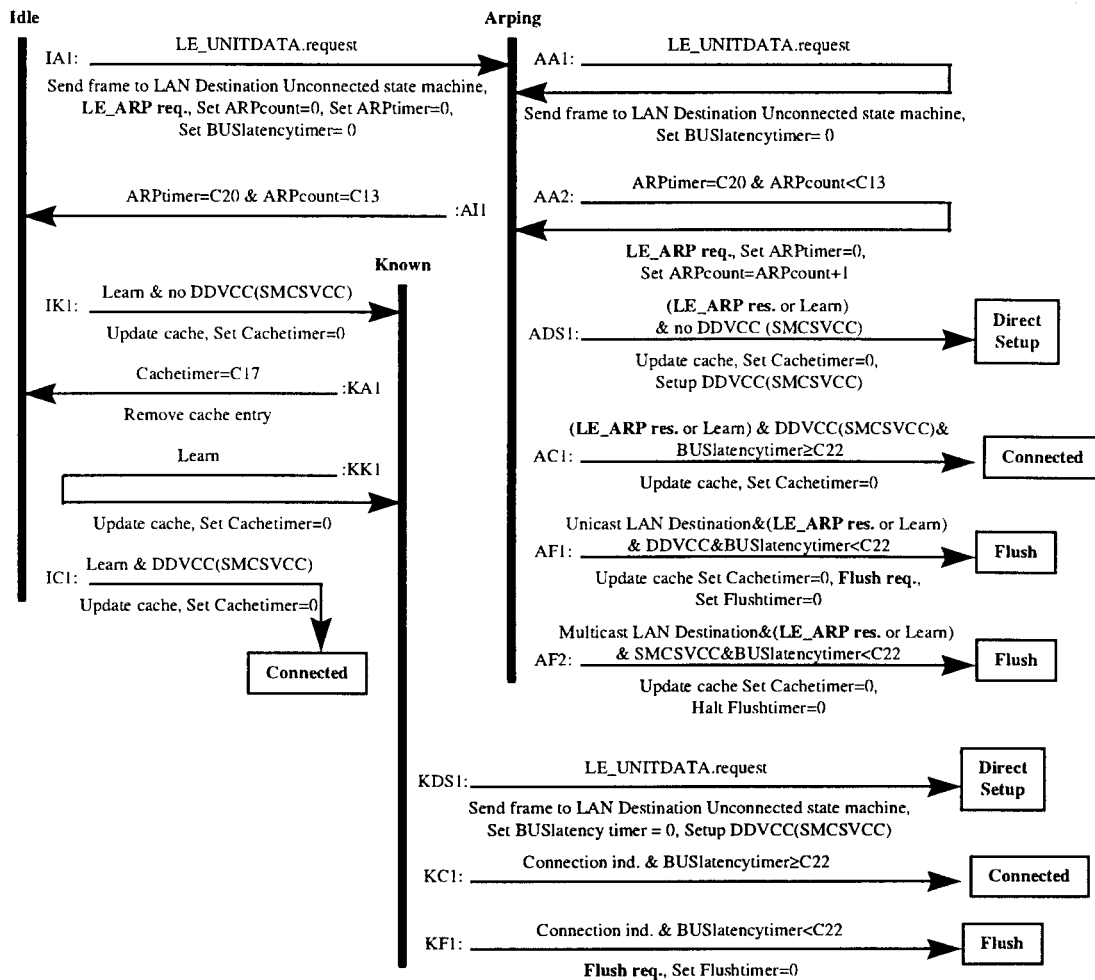

Figure 14. LAN Destination State Machines (Part 1)

- IA1: When the higher layer issues an `LE_UNITDATA.request` with the LAN Destination and `qos_handle` pair for this state machine, the frame conveyed by the `LE_UNITDATA.request` is sent to the LAN Destination Unconnected state machine for sending to the BUS and the `BUSlatencytimer` is initialized to 0. In addition, an `LE_ARP` request is issued and the `ARPcount` and `ARPTimer` are initialized to control `LE_ARP` retries while in the Arping state.
- IK1: When the ATM address for the LAN Destination is learned through some means but an `LE_UNITDATA.request` was not issued and a `DDVCC(SMCSVCC)`<sup>27</sup> does not exist, the cache is updated, the `Cachetimer` is initialized to 0, and the Known state is entered.
- IC1: If the conditions of IK1 are met except that a `DDVCC(SMCSVCC)` exists, the cache is updated, the `Cachetimer` is initialized to 0, and the Connected state is entered.

<sup>27</sup> If the LAN Destination is a unicast address, then a data direct VCC (DDVCC) is to be setup. If the LAN Destinatin is a multicast address, then a selective multicast send VCC (SMCSVCC) is to be setup.

- AA1: LE\_UNITDATA.requests while in the Arping state cause the associated frame to be sent to the LAN Destination Unconnected state machine for sending to the BUS and the BUSlatencytimer to be initialized to 0.
- AA2: If the LE\_ARP response is not received within the interval C20, the LE\_ARP request is sent again provided the number of retries is less than C13.
- AII: Arping is retried at most C13 times if an LE\_ARP response is not received.
- ADS1: If an LE\_ARP response is received or the ATM address for LAN Destination is learned through some other means and no DDVCC(SMCSVCC) exists, the cache is updated, the Cachetimer is initialized to 0, and a setup of a DDVCC(SMCSVCC) is initiated.
- AC1: If an LE\_ARP response is received or the ATM address for LAN Destination is learned through some other means and a DDVCC(SMCSVCC) exists, the cache is updated, the Cachetimer is initialized to 0. This transition is also conditioned on at least C22 seconds having passed since a frame was sent to the BUS which means that the Flush protocol is not required. Consequently the Connected state is entered.
- AF1: The transition conditions are similar to AC1 with the exception that a frame was sent to the BUS less than C22 seconds earlier. This means that a Flush request is issued in addition to updating the cache and initializing the Cachetimer and the Flushtimer to 0.
- AF2: The transition conditions are similar to AF1 with the exception that the LAN Destination is a multicast address. In this case no Flush request is sent and the Flushtimer is stopped. The effect is to not send a frame until the BUSlatencytimer reaches C22. (See transition FC1.)
- KA1: When the cache entry has not been verified after C17 seconds, the entry is removed and the Idle state is entered.
- KK1: If a ATM address is learned for the LAN Destination, the cache entry is updated and the Cachetimer is reset to 0.
- KDS1: If a LE\_UNITDATA request is issued, the associated frame is sent to the LAN Destination Unconnected state machine for sending to the BUS and the BUSlatencytimer is initialized to 0. Also, the setup of a DDVCC(SMCSVCC) is begun.
- KC1: If a suitable DDVCC is setup for the cache entry (proper LAN Destination and call setup parameters) the Connected state is entered provided the BUS has not been used in the last C22 seconds.
- KF1: If a suitable DDVCC is setup for the cache entry (proper LAN Destination and call setup parameters) but the BUS was used in less than C22 seconds before, a Flush request is issued and the Flushtimer is initialized to 0.

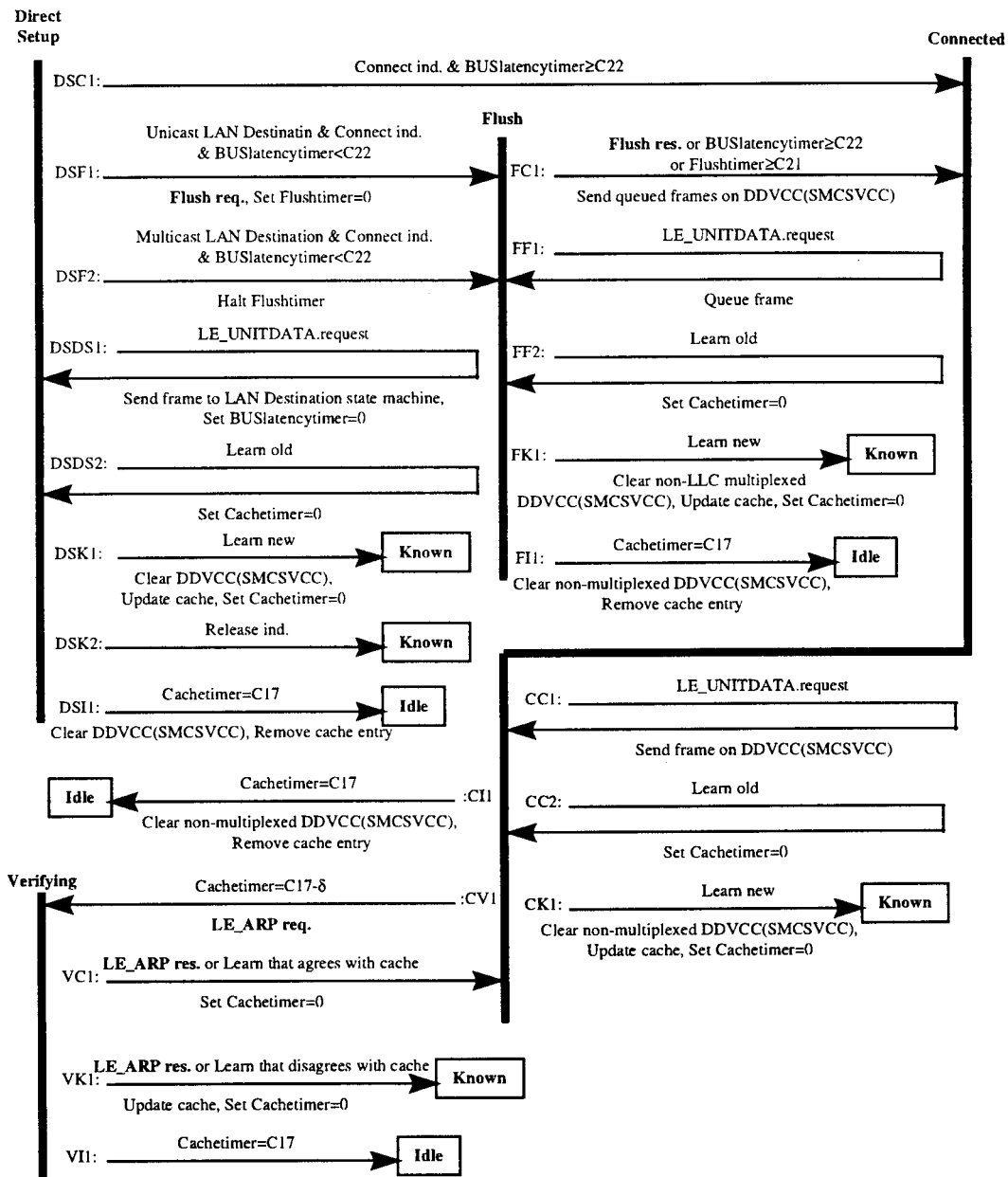

Figure 15. LAN Destination State Machine (Part 2)

- DSC1: Upon setup of the DDVCC(SMCSVCC), if at least C22 seconds have passed since the BUS was used, the Connected state is entered.
- DSF1: Upon setup of the DDVCC for a unicast LAN Destination, if the bus was used less than C22 seconds before, the flush process is started.
- DSF2: Upon setup of the SMCSVCC for a multicast LAN Destination, if the bus was used less than C22 seconds before, frames are held until the BUSlatency timer expires. (The Flush protocol is not used for SMCSVCCs. See FC1.)



- DSDS1:** While waiting for the DDVCC to be setup, frames from LE\_UNITDATA requests are sent to the BUS via the LAN Destination Unconnected state machine.
- DSDS2:** If a LAN Destination to ATM address binding is learned that is the same as the current cache entry, the Cachetimer is set to 0.
- DSK1:** If a LAN Destination to ATM address binding is learned that is the different from the current cache entry, the cache is updated, the Cachetimer is set to 0, and the Known state is entered. The setup process for the DDVCC(SMCSVCC) is also terminated.
- DSK2:** If the setup of the DDVCC fails, the Known state is entered.
- DSI1:** If the age of the cache entry becomes too large, the setup process for the DDVCC(SMCSVCC) is terminated, the cache entry is removed, and the Idle state is entered.
- FC1:** If the Flush response is received or the time since a frame was sent to the BUS reaches **C22** seconds or the time since a Flush request was sent reaches **C21** seconds, then the queued frames are sent on the DDVCC(SMCSVCC) and the Connected state is entered.
- FF1:** Frames associated with all LE\_UNITDATA requests are queued while in the Flush state.
- FF2:** If a LAN Destination to ATM address binding is learned that is the same as the current cache entry, the Cachetimer is set to 0.
- FK1:** If a LAN Destination to ATM address binding is learned that is the different from the current cache entry, the cache is updated, the Cachetimer is set to 0, and the Known state is entered. The DDVCC(SMCSVCC) is also cleared unless it is an LLC Multiplexed DDVCC.
- FI1:** If the age of the cache entry becomes too large, the cache entry is removed, and the Idle state is entered. Also, if the DDVCCC is non-multiplexed, it is cleared.
- CI1:** If the age of the cache entry becomes too large, the cache entry is removed, and the Idle state is entered. Also, the DDVCCC(SMCSVCC) is cleared unless it is an LLC-multiplexed DDVCC.
- CC1:** Frames received via LE\_UNITDATA requests are sent to the DDVCC(SMCSVCC).
- CC2:** If a LAN Destination to ATM address binding is learned that is the same as the current cache entry, the Cachetimer is set to 0.
- CV1:** When the cache entry is close to aging out, an attempt is made to verify it by issuing an LE\_ARP request. The Verifying state is entered.
- CK1:** If a LAN Destination to ATM address binding is learned that is the different from the current cache entry, the cache is updated, the Cachetimer is set to 0, and the Known state is entered. The DDVCC(SMCSVCC) is also cleared unless it is an LLC-multiplexed DDVCC.
- VC1:** If a LAN Destination to ATM address binding is learned that is the same as the current cache entry, the Cachetimer is set to 0.
- VK1:** If a LAN Destination to ATM address binding is learned that is the different from the current cache entry, the cache is updated, the Cachetimer is set to 0, and the Known state is entered. The DDVCC is also cleared unless it is an LLC Multiplexed DDVCC.
- VII:** If the age of the cache entry becomes too large, the cache entry is removed, and the Idle state is entered. Also, if the DDVCCC is non-multiplexed, it is cleared.

There is a LAN Destination Unconnected State Machine for each possible LAN Destination. This state machine makes state transitions based on stimuli from the many LAN Destination State machines described in Appendix A.3.

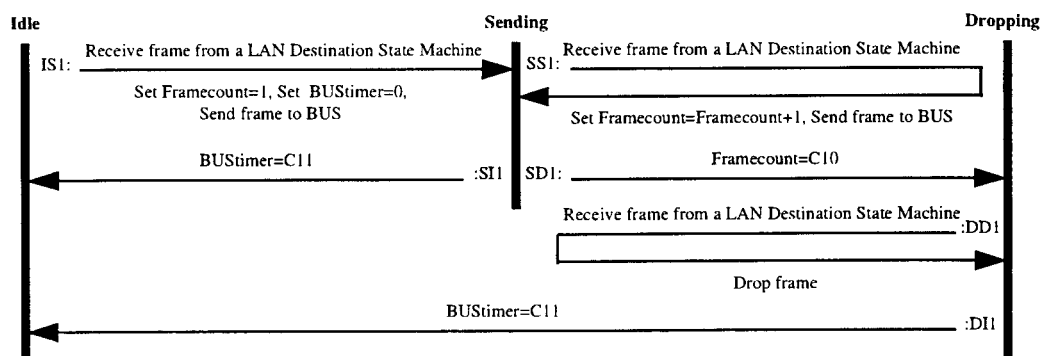

Figure 16. LAN Destination Unconnected State Machine

- IS1: When a frame is received from a LAN Destination State machine, the frame is sent to the BUS. In addition, the Framecount and BUS timer are initialized. These variables are used to restrain the flow of unicasts to the LAN Destination that are sent to the BUS to be less than C10 per C11.<sup>28</sup>
- SS1: When a frame is received from a LAN Destination State machine, the frame is sent to the BUS and the Framecount is incremented.
- SD1: If the Framecount reaches C10, the Dropping state is entered. No frames to the LAN Destination will be sent to the BUS while the state machine is in the Dropping state.
- SI1: When the BUS timer reaches C11, the Idle state is entered.
- DD1: Any frame received while in the Dropping state is dropped.
- DI1: When the BUS timer reaches C11, the Idle state is entered.

<sup>28</sup> There can be time intervals of C11 where more than C10 frames are sent to the BUS. However, over a long term measurement interval (say several C11's) the rate is no more than C10 per C11.

## Appendix B Special Topics

### B.1 Maximum Frame Size Calculation

**IEEE 802.3/Ethernet** MAX Frame size is based on the maximum of 1518 octets for the DA (6 octets), SA (6 octets), Type/Length (2 octets), Info (1500 octets), and FCS (4 octets) fields. Since LANE data frames also includes the 2 octet LAN Emulation Header (LEH) but does not include the FCS field, the Emulated Ethernet MAX Frame Size is **1516 octets** (LEH, DA, SA, Type/Length, and Info fields). This results in 32 ATM cells (48 octets payload per cell) or 1536 octets including 12 octets of pad and the 8 octet trailer.

**IEEE 802.1p/Q** MAX Frame Size is based on the IEEE 802.3/Ethernet MAX Frame size. Work in progress in the IEEE 802.1 committee is, at this writing, leading towards LLC and/or Ethertype headers which may be added to a maximum-length IEEE 802.3/Ethernet data frame. These headers are placed between the Source/Destination MAC addresses and the Ethertype/Length field. The IEEE 802.1p/Q MAX Frame size allocates an additional 64 octets to accommodate such additional header information. Size is **1580 octets** (LEH, DA, SA, 802.1p/Q header, Type/Length, and Info fields). This results in 34 ATM cells (48 octets payload per cell) or 1632 octets including 44 octets of pad and the 8 octet trailer.

**IEEE 802.5 Token Ring** MAX Frame Size is based on the 9.1 msec token holding timer which allows for 4550 octets at 4 Mbps operation and 18200 octets at 16 Mbps operation. These lengths include the starting delimiter (SD=1 octet), access control (AC=1 octet), frame control (FC=1 octet), DA (6 octets), SA (6 octets), RI (0 to 30 octets), INFO, FCS (4 octets) fields, Ending delimiter (ED=1 octet), frame status (FS=1 octet) field, and the inter-frame gap (IFG). The minimum IFG for 4 Mbps operation is 1 octet and is 5 octets for 16 Mbps operation. Since the LANE data frame includes the 2 octet LEH but does not include the SD, FCS, ED, FS, and IFG, the Emulated Token Ring MAX Frame Size is **4544 octets** for 4 Mbps and **18190 octets** for 16 Mbps. For 4 Mbps operation this results in 95 ATM cells or 4560 octets including 8 octets of pad and the 8 octet trailer. For 16 Mbps operation this results in 380 ATM cells or 18240 octets including 42 octets of pad and the 8 octet trailer.

**RFC 1626 "Default IP MTU for use over AAL5"** MAX Frame Size is based on a maximum MTU of 9180 octets for the user\_data plus 8 octets for the LLC/SNAP header. This length does not include the AC (1 octet), FC (1 octet), DA (6 octets), SA (6 octets), and RI (0 to 30 octets) fields. Since the LANE data frame includes the 2 octet LEH the Emulated Token Ring MAX Frame Size is **9234 octets**. This results in 193 ATM cells or 9264 octets including 22 octets of pad and the 8 octet trailer.

The following table shows the basis and how the maximum frame size has been determined. All of the non-multiplexed AAL5 SDU sizes are increased by 12 octets for LLC-multiplexed frames carried on LLC-multiplexed VCCs.

Table 43. Maximum Frame Size Calculation

Non Muxed AAL5 SDU Max. octets	Non Muxed AAL5 PDU Max. octets	Fields:	Basis:	
1516	1536 (32 cells)	LEH, DA, SA, Type/Length, INFO	802.3/Ethernet	1500 octets Info field
1580	1632 (34 cells)	LEH, DA, SA, 802.1p/Q Header, Type/Length, INFO	802.1p/Q Draft	
4544	4560 (95 cells)	LEH, AC, FC, DA, SA, RI, INFO	802.5 4Mbps	9.1 msec THT
9234	9264 (193 cells)	LEH, AC, FC, DA, SA, RI, INFO	802.5 16Mbps	RFC 1626 Default IP MTU for use over ATM AAL5
18190	18240 (380 cells)	LEH, AC, FC, DA, SA, RI, INFO	802.5 16Mbps	9.1 msec THT

Note: IEEE 802.3 and 802.5 INFO field includes the 8 octet LLC/SNAP header

AAL5 PDU size = SDU size + 8 (PDU trailer) + pad to 48\*n octets

## B.2 Token Ring Source Routing Information and Structures

This annex explains how the LE Client decodes the source routing information in a frame.

- How to determine if the RI field is present.
- How to determine the RI\_type.
- How to determine if the ELAN is the last hop.
- How to determine the next\_RD when the ELAN is not the last hop.

### B.2.1 Determining if the Routing Information Field is Present.

The frame's source address (SA) field identifies the station that originated the frame. In contrast to the DA field, the Individual/Group (I/G) bit is not encoded in the SA since the SA is constrained to be an individual address and thus the implied value for the I/G is always 0. In its place is the routing information indicator (RII) bit used to indicate the presence or absence of a Routing Information (RI) field in the frame. If the RII bit is 0, then no RI field is present (i.e., an NSR frame). If the RII bit is 1, then the RI field is present. There is no change to the Universal/Local (U/L) bit which still indicates whether the address is universally or locally administered (same as the DA field).

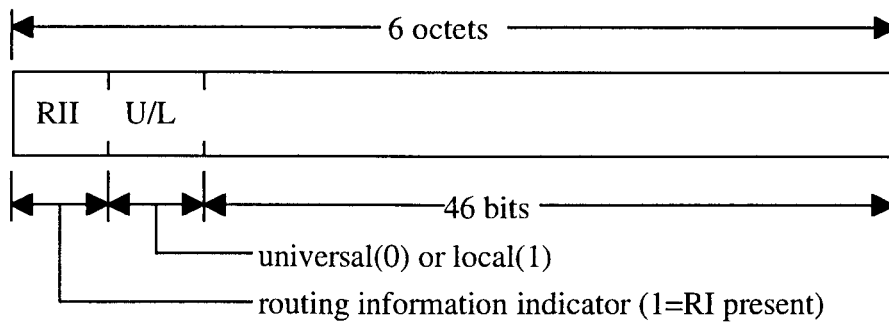

Figure 17. Source Address Field

**B.2.2 ROUTING INFORMATION (RI) FIELD Format.**

When a frame's routing information indicator bit in the source address field is equal to 1 (RII=1), the RI field is included in the frame. The RI field immediately follows the SA field as shown in Figure 18. The following provides sufficient information for a LE Client to determine the size of the RI field and parse the frame properly. The detailed structure and contents for the RI field are described in ISO/IEC 10038 (IEEE 802.1D) [4] and ISO/IEC 8802-2 (IEEE 802.2) [8].

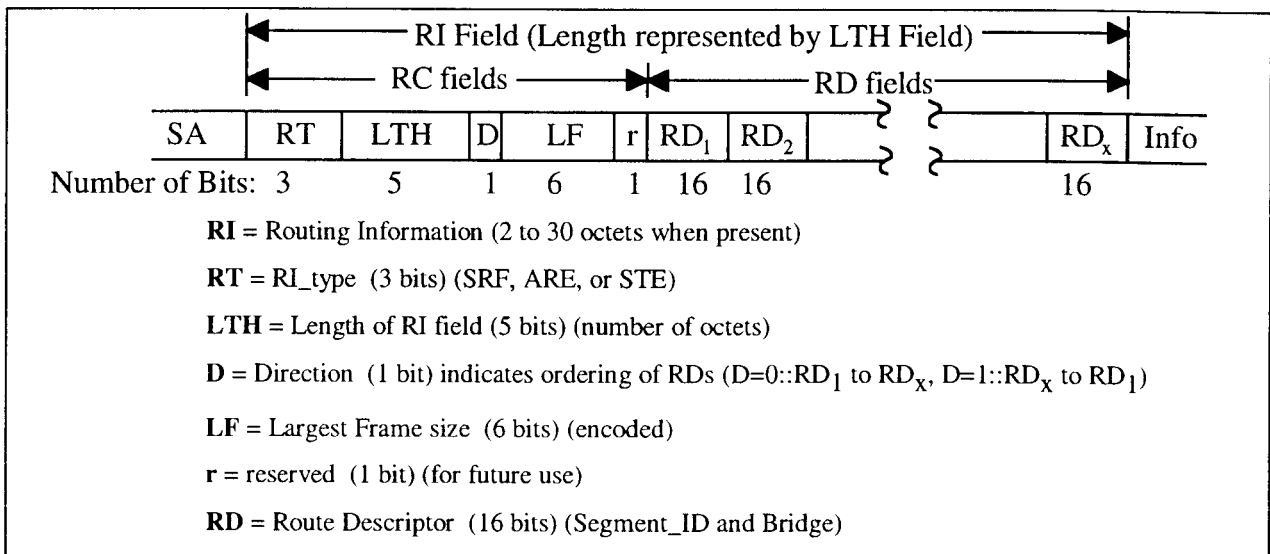

Figure 18. Routing Information Field Content

Figure 19 shows the detailed format for the RI field<sup>29</sup>.

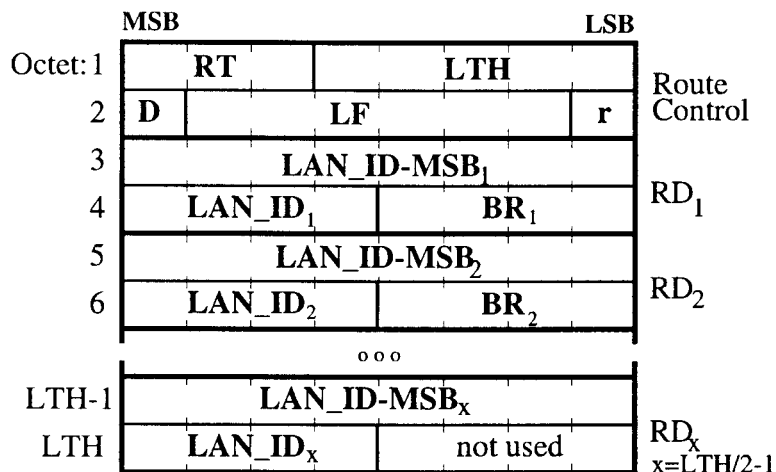

Figure 19. Routing Information Field Format

**RI Type (RT).** These three bits indicate the type of the RI field.

RT=000: Specifically Routed Frame (SRF)

RT=10x: All Routes Explorer (ARE)

RT=11x: Spanning Tree Explorer

**LENGTH BITS (LTH).** These five bits indicate the length (in octets) of the RI field. LTH field values are even values between 2 and 30 inclusive.

**Direction (D).** This bit indicates the direction that the frame is traversing the specified LANs. If the D bit is 0, then the frame is traversing the LANs in the order in which the RDs are specified (RD<sub>1</sub> to RD<sub>2</sub> to ... to RD<sub>x</sub>). Conversely, if the D bit is set to 1, the frame will traverse the LANs in the reverse order (RD<sub>x</sub> to RD<sub>x-1</sub> to ... to RD<sub>1</sub>). The D bit is only meaningful for SRF frames.

<sup>29</sup>See [11].

**Largest Frame bits (LF).** These 6 bits are used to indicate the largest frame that may traverse the specified route. These bits are not meaningful to the LE Client entity.

**reserved (r).** This bit is reserved for future use.

**Route Descriptor (RD).** Each route descriptor consists of 16 bits as indicated in Figure 20.

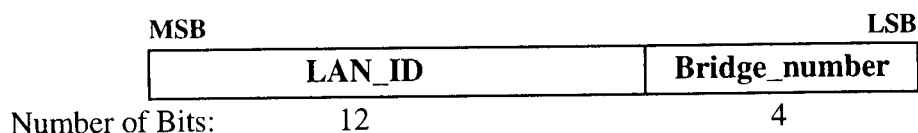

Figure 20. Route Descriptor Format

### B.2.3 Determining the "Next\_RD"

The "next\_RD" is the term used to describe the Segment\_ID and Bridge Number to the next LAN segment. An RI field is built by sending an explorer (ARE or STE) frame through the bridged network. When the RI field is built, each bridge that forwards the frame adds portions of the information until the RI field contains the Segment\_ID of the each of the segments and the relative bridge number between any two segments. The information to determine the "next\_RD" is relative to the position of the ELAN's Segment\_ID and the value of the D bit. The "next\_RD" is only applicable for SRF frames.

When the length of a SRF's RI field is less than 6, then there are no hops and the destination is on this ELAN. When the length is 6 or more, the LE Client searches the Segment\_IDs in the RI field of the SRF frame until it finds the one that matches the Segment\_ID of the emulated LAN. This is  $RD_n$  and contains  $\{Segment\_ID_n, BR_n\}$ . The LE Client which is not part of a source routing bridge may assume that  $RD_n$  is the first RD in the list ( $RD_1$ ) when the direction bit (D) is 0 or the last RD in the list ( $RD_x$ ) when  $D=1$ . If  $D=0$  and  $RD_n$  is the last RD in the list, then there is not a "next\_RD" and the last hop is this ELAN (i.e., the destination is on the local ELAN segment). Also if  $D=1$  and  $RD_n$  is the first RD in the list, then there is not a "next\_RD" and the last hop is this ELAN. Otherwise this ELAN is not the last hop and the SRF frame needs to be forwarded to the bridge as specified by the "next\_RD".

The RD immediately before  $RD_n$  is  $RD_{n-1}$  and it contains  $\{Segment\_ID_{n-1}, BR_{n-1}\}$ . The RD immediately after  $RD_n$  is  $RD_{n+1}$  and it contains  $\{Segment\_ID_{n+1}, BR_{n+1}\}$ . When the direction bit (D) is 0 then the "next\_RD" is the Segment\_ID from the  $RD_{n+1}$  and the bridge number from  $RD_n$ . When the D bit is 1, the "next\_RD" is composed of the Segment\_ID and bridge number from  $RD_{n-1}$ .

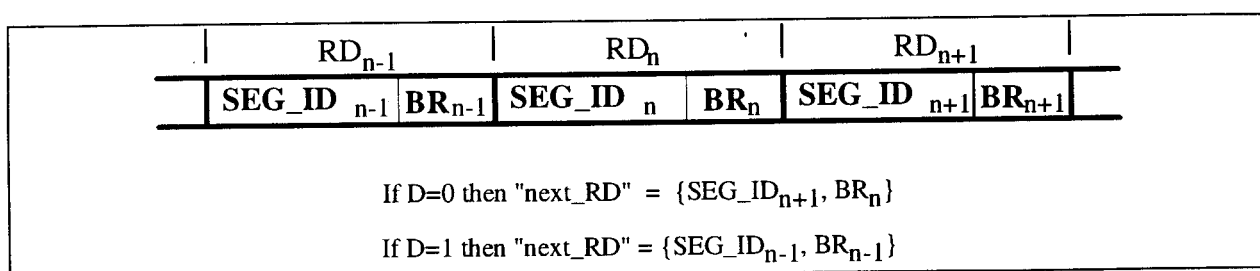

Figure 21. Extracting "next\_RD"

## B.3 Interworking with FDDI LANs

When interworking with FDDI LANs, it is necessary for an internetworking device to map to a LE Client which is a member of either a Ethernet/802.3 or Token-Ring/802.5 emulated LAN. This requires that a device operating as a bridge convert FDDI LAN data frames into frames for one of the defined ATM emulated LAN types as a translating bridge.

Procedures for converting to Ethernet frame formats are defined in [802.1h] and to IEEE 802 [802.11]. There also exist published specifications for mapping to 802.5/Token-Ring [IBM] [802.1x] and for running network layer protocols over such IEEE 802 networks e.g. [RFC 1042] [RFC 1188].

Note that, because LAN Emulation supports IEEE 802.3-like data frame formats with length greater than 4500 bytes, an emulation of a FDDI LAN may be achieved without fragmentation of frames according to established standards without requiring a separate "emulated FDDI" LAN type.

**Example configurations**

1. Connecting existing FDDI backbones together using ATM

Bridges and routers can use ATM LAN Emulation to connect efficiently between FDDI LANs without the cost of frame fragmentation. The ATM emulated LAN (ELAN) may be defined to use either of the LAN Emulation frame formats defined in this specification.

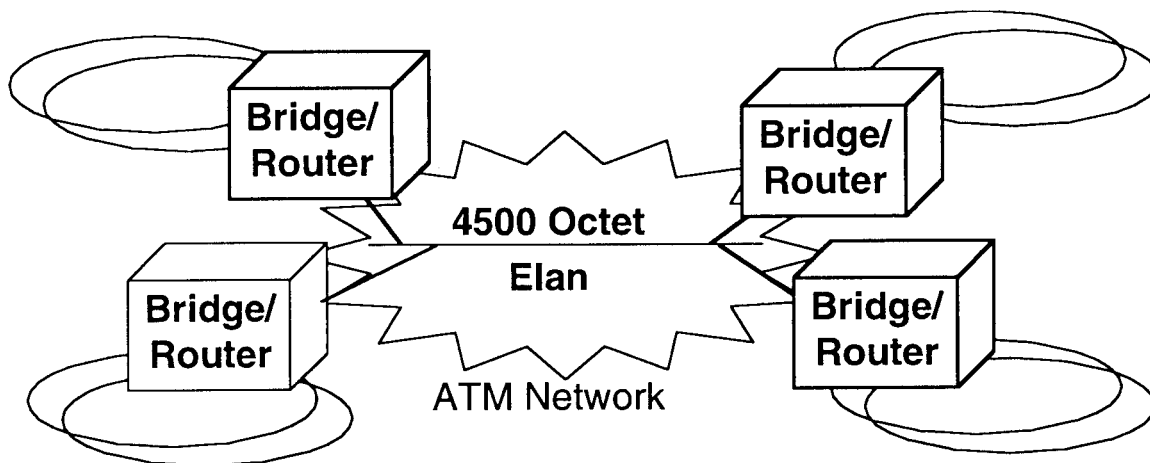

Connecting existing FDDI backbones

2. Replacement of FDDI by ATM as a high-performance host/server interconnect:

ATM LAN Emulation allows similar efficiency for communication across ATM when compared to FDDI: stations may still use 4500 octet MTU or even higher MTUs up to 18k octets, if desired, for more efficiency. The ELAN may be defined to use either of the LAN Emulation frame formats defined in this specification. ATM-to-FDDI concentrators may be used if it is desired to keep devices on same LAN as FDDI stations; bridges or routers may be used if it is desired to separate the ATM ELAN from a FDDI LAN.



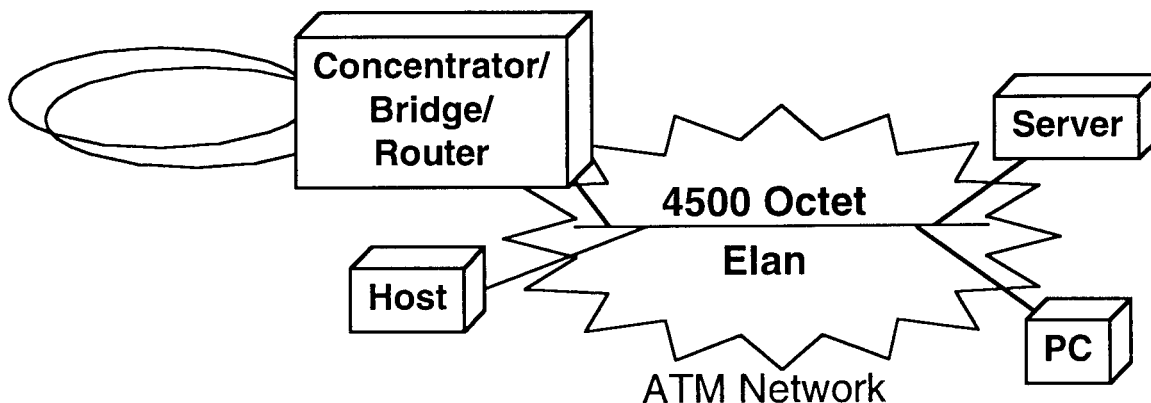

Replacing FDDI by ATM in Hosts

3. Replacement of FDDI by ATM in a mixed Ethernet/FDDI host environment:

As with traditional LANs, translation bridges may be used to connect segments using different encapsulations or MTUs. The technologies and standards used to do this still apply in the ATM LAN Emulation world:

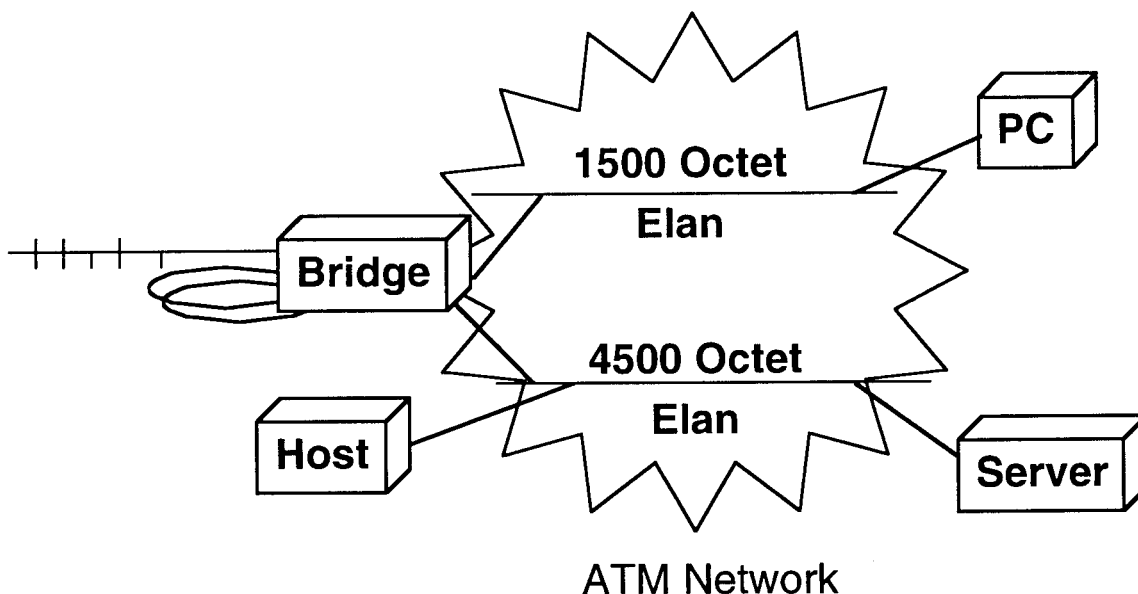

Ethernet/FDDI mixed -> ATM hosts (1)

This specification supports use of 'mixed MTU' devices on the same emulated LAN where the upper layer protocols permit this. One possible example would be if an ATM NIC card joins a 4500-octet ELAN: if upper layer protocol uses a smaller MTU, the NIC can discard received frames which are too long for the upper-layer protocol. In other cases, higher layer protocols will automatically lower or negotiate the MTU size between pairs of destinations. This scenario offers several advantages including minimizing the amount of configuration and management by users and reducing the number of hops through intermediate bridges:

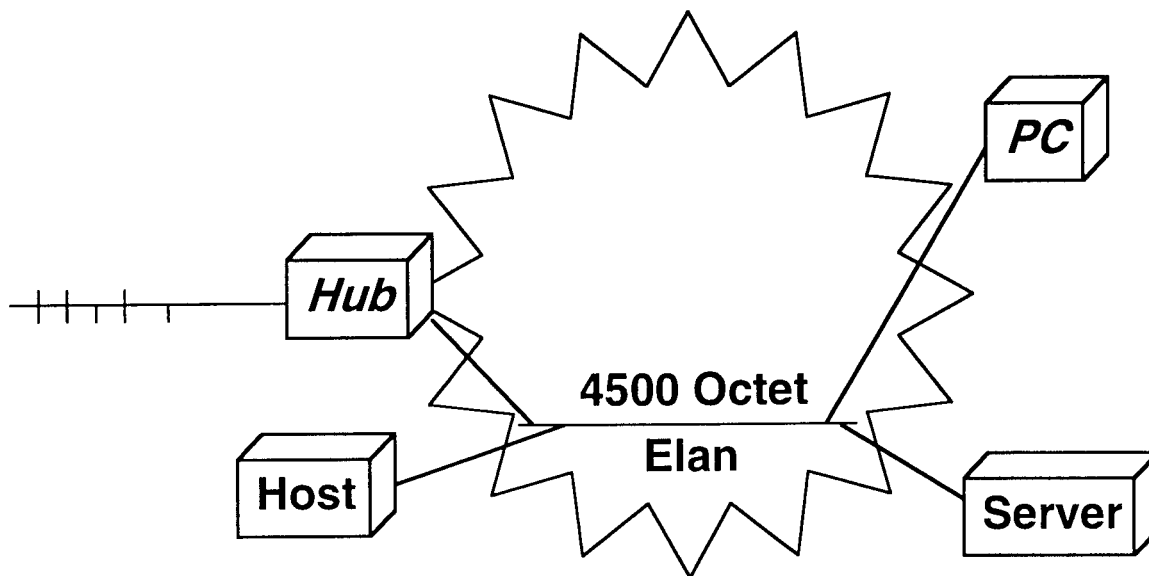

Ethernet/FDDI mixed -> ATM hosts (2)

#### References

The following references pertain to mixed-media bridging over LANs:

- [802.1h] "MAC Bridging of Ethernet V2.0 in IEEE 802 Local Area Networks" IEEE P802.1h/D4 1/12/93
- [802.1i] "Local Area Networks MAC Bridges FDDI Supplement" IEEE P802.1i/D3 6/30/91
- [802.1x] "MAC Bridges - Source-Routing Supplement" IEEE P802.5m/P802.1x/D5 8/15/91
- [RFC 1042] "A Standard for the Transmission of IP Datagrams over IEEE 802 Networks" Reynolds & Postel, IETF, May 1987
- [RFC 1188] "A Proposed Standard for the Transmission of IP Datagrams over FDDI Networks" Katz, IETF, October 1990
- [IBM] "The IBM 8209 LAN Bridge" Latif et al., IEEE Network Magazine, May 1992

## Appendix C Network Management Considerations

Network management of a LAN Emulation Client is defined using SNMP MIBs. Several MIBs are relevant, including:

- RFC 1573 - Evolution of the Interfaces Group of MIB-II
- RFC 1695 - Definitions of Managed Objects for ATM Management, otherwise known as the AToM MIB
- The ATM Forum, *LAN Emulation Client Management Specification Version 1.0*, af-lane-0038.000, September 1995
- The ATM Forum, *LAN Emulation Servers Management Specification Version 1.0*, af-lane-0057.000, March 1996

## Appendix D New LANE v2 Features

### D.1 Summary of LANE v2 Features

LUNI v2 has introduced many new concepts to LAN Emulation. The list below is an attempt to enumerate many of the new features of LANE v2, and whether these features are optional or mandatory for the LE Clients and Service.

This list is not complete, nor does it express the many facets of any particular feature.

**Table 44. Summary of LANE v2 Features**

	Mandatory at LE Client	Mandatory at LE Service
Changes to Configuration Variables	Yes	Yes
Extended Set of TLVs	Yes	Yes
ARP-based TLVs	Yes	Yes
Extended API to Higher Layers	Yes	N/A
Quality of Service	No	N/A
Multicast Services	No	No*
LLC-multiplexing	No	N/A
Support for SIG 4.0	No	No
Targetless LE_ARP and no source LE_NARP	Yes	Yes

(\* Registering multicasts required, extended multicast support optional)

A minimal version 2 LE Client supports the set of configuration variables and TLVs identified in this specification, associates TLVs in LE\_ARP responses with entries in its LE\_ARP cache, and provides a higher layer interface to access the TLVs associated with LE\_ARP entries. A LANE v2 LE Client is not required to support Quality of Service, Multicast Services, LLC-based VCC multiplexing, or SIG 4.0.

Similarly, a minimal LE Service supports the extended set of configuration variables and TLVs of this specification, as well as ARP-based TLVs. The LE Service is also required to support LE\_ARPs and registers for multicast addresses, although it is not required to provide any extended services for multicasts.

As seen in the above table, a minimal LANE v2 LE Client or LE Service can be obtained from a LANE v1 LE Client or LE Service with relatively simple enhancements.

### D.2 MPOA Requirements

The Multiprotocol over ATM protocol (MPOA) requires a LANE implementation which supports the minimal requirements of this specification.

### D.3 Compatibility between LANEv1 and LANEv2

#### D.3.1 LANEv2 With LANEv1 LE Service Components

When a LANE v2 capable LE Client interacts with LANE v1 compliant components of the LAN Emulation Service, the LE Client MUST NOT perform any actions which the LANEv1 Server components will consider as illegal. However, a LE Client MAY include TLVs on the LE\_REGISTER\_REQUESTs and LE\_ARP\_RESPONSEs it generates. Although the information included in such TLVs might or might not reach other LANEv2-capable LE Clients, there are benefits if it does reach other LE Clients. However, protocols such as MPOA which depend on the

information carried in those TLVs will not work correctly. The LE Client can detect this situation using the V2 Capable and V2 Required FLAGS bits during the Join phase.

### D.3.2 LANE v2 With LANE v1 Clients

LANE v2 compliant LE Service components MUST support LANE v1 compliant LE Clients such that all LANE v1 capabilities of the LANE v1 LE Clients are maintained.

### D.3.3 A Mixture of LANE v1 and LANE v2 Clients

By using different B-LLI values, all LLC-multiplexed Data Direct VCCs can be distinguished from non multiplexed Data Direct VCCs. Except for the 12-byte header, all frame formats are identical between LLC-multiplexed and non-multiplexed. By adding or deleting the LLC multiplexing header on a per-VCC basis, compatibility between LANE v1 and LANE v2 is achieved. In particular, LANE v2 supports a mixture of non-multiplexed and LLC-multiplexed connections on the same ELAN without requiring any changes to the LANE v1 LE Clients. Of course, this level of compatibility is not without cost to the LANE v2 components.

Compatibility at the level of allowing an arbitrary mixture of non-multiplexed and LLC-multiplexed LE Clients on the same ELAN requires several modifications in LANE v2 to the procedures used in LANE v1:

1. A new TLV is in the LE\_CONFIGURE\_RESPONSE to indicate to a LANE v2 LE Client the value of the ELAN-ID of the ELAN.
2. A new TLV, the LLC-Muxed ATM Address TLV, is defined for the LE\_ARP\_REQUEST, LE\_ARP\_RESPONSE, LE\_NARP\_REQUEST and LE\_REGISTER\_REQUEST frames. The presence of this TLV tells the receiver that the transmitting LE Client is able to use LLC-multiplexed VCCs, and conveys the ATM address that must be used for any LLC-multiplexed Data Direct VCCs.
3. The LANE v2 LE Client must keep track of which Data Direct VCCs are non-multiplexed and which are LLC-multiplexed. It expects/adds the LLC headers on LLC-multiplexed VCCs, but not on non-multiplexed VCCs.

By keeping all frame formats identical between LANE v1 and LANE v2, except for the LLC header and a few flags and TLVs, the effort required to meet the requirement for interoperability with LANE v1 is minimized.

LANE v2 takes advantage of a particular feature of the LANE v1 specification: that unused fields in all control frames are required to be transmitted with a value of 0, and are required to be ignored on receipt. LANE v2 therefore defines uses for bits and fields unused in LANE v1, and allows those fields to be transmitted to LANE v1 components, without risk of disrupting their operation.

## Appendix E Summary of ISO 10747

This appendix describes the format of the layer 3 address carried in the Layer-3-Address TLV. The following is a non-normative description of the format in ISO 10747 [22].

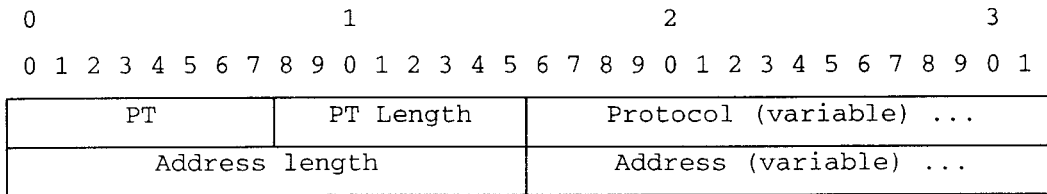

**Figure 22. ISO 10747 Address Format**

**PT** Protocol type:

1 = NLPID format

2 = 802.2 format (see [8])

**PT Length.** Length of protocol field, 1 for PT = 1, and either 3 or 8 for 802.2 format depending if SNAP is used for PT = 2.

**Protocol:**

0x81 - CLNS (PT = 1)

0xCC - IPv4 (PT = 1)

0xAAAA03 000000 0800 - IPv4 (PT = 2)

0xAAAA03 000000 86DD - IPv6 (PT = 2)

0xAAAA03 000000 6003 - DECNET Phase IV (PT = 2)

0xAAAA03 000000 809B - AppleTalk (PT = 2)

0xAAAA03 000000 8137 - Novell IPX (PT = 2)

0xAAAA03 000000 80c4 - Vines (PT = 2)

0xAAAA03 000000 0600 - Xerox XNS (PT = 2)

0xAAAA03 000000 8019 - Apollo Domain (PT = 2)

**Address length.** Length of address field in bytes.

**Address.** Address of interface or system if addresses not assigned to interfaces. For CLNS, the address contains a 1-byte length, in bytes, followed by the address.

End of Document

第1版 執筆作成協力者 (敬称略) (1998年1月27日現在)

( JF-AF0084.00 制定 )

第三部門委員会

部門委員長 飯島 裕雄 日本電気(株)  
副部門委員長 吉田 慎一郎 日本電信電話(株)  
副部門委員長 森 淳 沖電気工業(株)

委員	田中 寛	国際電信電話(株)	委員	蟻川 義男	東京電力(株)
"	大貫 雅史	NTT 移動通信網(株)	"	中村 寿博	日本情報通信コンサルティング(株)
"	鈴木 一道	エフ・ティ・ティ・データ通信(株)	"	小川 研一	富士通(株)
"	牟田 総男	岩崎通信機(株)	"	中山 文信	(株)東芝
"	勝川 保	住友電気工業(株)	"	森田 隆士	(株)日立製作所
"	酒井 一郎	日本アイ・ビー・エム(株)	"	久保 輝幸	日本電信電話(株)
"	青山 滋	三菱電機(株)	"	小林 信之	三菱電機(株)
"	井坂 章	(株)リコー			

第三部門委員会第二専門委員会

専門委員長 森田 隆士 (株)日立製作所  
副専門委員長 久保 輝幸 日本電信電話(株)  
副専門委員長 小林 信之 三菱電機(株)

委員	後藤 俊彦	東京通信ネットワーク(株)	委員	坂本 篤	日本ビクター(株)
"	高橋 英範	日本電信電話(株)	"	宮川 徳一	日本無線(株)
"	三宅 篤	大阪メディアポ - ト(株)	"	木下 成顕	(株)日立製作所
"	小川 剛	アンリツ(株)	"	大西 洋也	(株)フジクラ
"	角田 靖夫	岩崎通信機(株)	"	小沢 祐治	富士ゼロックス(株)
"	千村 保文	沖電気工業(株)	"	若狭 慎司	富士通(株)
"	高橋 匠	キヤノン(株)	"	難波 美香子	古河電気工業(株)
"	川尻 康夫	国際電気(株)	"	森 孝志	松下通信工業(株)
"	西田 正樹	シャープ(株)	"	佐藤 浩之	三菱電機(株)
"	大間 稔	住友電気工業(株)	"	寺尾 雄一	(株)リコー
"	関 豊	(株)東芝	"	山崎 哲哉	(株)アルファシステムズ
"	金田 佳久	日本アイ・ビー・エム(株)	"	岩倉 久純	東京電力(株)
"	坂本 秀紀	日本電気(株)	"	加藤 芳章	日本情報通信コンサルティング(株)

[JF-AF0084.00 制定 検討グループ]

リーダー	西田 正樹	シャープ(株)			
サブリーダー	大西 洋也	(株)フジクラ			
委員	後藤 俊彦	東京通信ネットワーク(株)	委員	宮川 徳一	日本無線(株)
"	高橋 英範	日本電信電話(株)	"	小沢 祐治	富士ゼロックス(株)
"	小川 剛	アンリツ(株)	"	松田 高男	富士通(株)
"	角田 靖夫	岩崎通信機(株)	"	難波 美香子	古河電気工業(株)
"	谷頭 昭夫	沖電気工業(株)	"	森 孝志	松下通信工業(株)
"	川尻 康夫	国際電気(株)	"	佐藤 浩之	三菱電機(株)
"	大間 稔	住友電気工業(株)	"	寺尾 雄一	(株)リコー
"	関 豊	(株)東芝	"	加藤 芳章	日本情報通信コンサルティング(株)
"	坂本 秀紀	日本電気(株)			

事務局 元吉 茂 (第三技術部)

JF-AF0084.00補遺  
LANエミュレーション  
バージョン2.0LUNI仕様補遺

第1版

1998年6月2日制定

社団法人  
情報通信技術委員会

THE TELECOMMUNICATION TECHNOLOGY COMMITTEE





<参考>

1. 目的

本補遺は、標準JF-AF0084.00を解説し、その実装上の理解を助ける目的で作成されたものである。

2. 規定範囲

本補遺は、標準JF-AF0084.00の内容に対して記述されたものである。

3. 改版の履歴

版数	発行日	改版内容	対応するTTC標準			
			番号	名称	発行年度	版数
第1版	1998年 6月2日	制定	JF-AF0084.00	LANエミュレーション バージョン2.0 LUNI仕様	1998	1

4. その他

参照しているTTC標準、国際勧告、業界標準等は、以下のとおりである。

TTC標準： JF-AF0084.00

JF-AF0021.00

The ATM Forum Specification：

af-uni-0010.001:ATM User-Network Interface Specification, Version3.0

af-uni-0010.002:ATM User-Network Interface Specification, Version3.1

af-uni-0061.000:UNI Signaling 4.0

# 目 次

1. 概要	3
1.1 LAN エミュレーション概要	3
1.2 LAN エミュレーションの範囲	3
1.2.1 対象となる LAN	3
1.2.2 規模	3
2. LAN エミュレーション バージョン 2.0 の機能	5
2.1 LAN エミュレーション バージョン 1.0 との差異	5
2.1.1 QoS のサポート	5
2.1.2 マルチキャスト機能の強化	6
2.1.2.1 概要	6
2.1.2.2 LUNI 要求事項	6
2.1.2.3 LAN エミュレーションエンティティの機能	6
2.1.2.4 コネクション	6
2.1.2.5 初期化プロトコル	6
2.1.2.6 ベリファイプロトコル	7
2.1.3 LLC 多重化	8
2.1.4 フレームフォーマット	8
2.2 MPOA からの要求事項	9
2.3 LAN エミュレーション バージョン 1.0 とのコンパチビリティ	9
2.3.1 バージョン 2.0 クライアントとバージョン 1.0 サービスコンポーネント	9
2.3.2 バージョン 1.0 クライアントとバージョン 2.0 サービスコンポーネント	9
2.3.3 バージョン 1.0 クライアントとバージョン 2.0 クライアント	9
3. 構成	10
3.1 エンティティ	10
3.2 コネクション	11
3.3 レイヤアーキテクチャ	14
3.4 共通技術	15
3.4.1 コネクションの確立	15
3.4.1.1 各フェーズにおけるコネクション	15
3.4.1.2 コネクションタイプ	15
3.4.1.3 コネクションの確立/解放の概要	16
3.4.1.4 QoS サポート	19
3.4.2 アドレス解決	20
3.4.2.1 サーバに相手先が登録されている時のアドレス解決動作について	20
3.4.2.2 サーバに相手先が登録されていない時のアドレス解決動作について	21
3.4.2.3 LE_ARP が適用される動作フェーズ	21
3.4.2.4 LAN エミュレーション バージョン 2.0 の ARP における TLV の拡張	21
3.4.3 TLV	22
4. 動作	26
4.1 各フェーズの流れ	26
4.2 各フェーズの動作	28

4.2.1	初期状態(Initial State).....	28
4.2.2	LECS 接続フェーズ(LECS Connect Phase) .....	28
4.2.3	コンフィグレーションフェーズ(Configuration Phase).....	29
4.2.4	ジョインフェーズ(Join Phase).....	30
4.2.5	登録フェーズ(Registration Phase).....	31
4.2.6	BUS 接続フェーズ(BUS Connect Phase).....	32
4.2.7	ブロードキャストデータ転送.....	33
4.2.8	ユニキャストデータ転送 .....	34
4.2.9	フラッシュ(Flush).....	36
4.2.10	ターミネーション(Termination).....	38
5.	LAN エミュレーションフレームフォーマット.....	40
5.1	オクテット及びビット順序 .....	40
5.2	LE データフレーム .....	41
5.3	LE コントロールフレーム .....	43

## 1. 概要

### 1.1 LAN エミュレーション概要

LAN エミュレーションは既存の LAN アプリケーションを ATM 網で使用するために MAC レイヤをエミュレートするものである。

LAN エミュレーションが提供する通信形態は

- ・ ATM による既存 LAN 間の接続
- ・ ATM 端末と既存 LAN 上の端末間の通信
- ・ ATM 端末間の通信

である。

LAN エミュレーションによってコネクションレス、マルチキャスト等の LAN の特徴がエミュレートされる。LAN エミュレーション バージョン 2.0 は、バージョン 1.0 と比較してよりきめ細かい QoS(Quality of Service) をサポートすることで、高度な通信品質の提供を可能とする。また、マルチキャスト機能の強化によってデータ送信先を指定してデータをマルチキャストできることから不要なトラフィックを削減し、LLC 多重化により MPOA(Multi Protocol Over ATM)をサポートすることでシステム規模を拡張することが可能となる。



図 1-1 / JF-AF0084.00 補遺 LAN エミュレーションのプロトコルスタック

図 1-1 / JF-AF0084.00 補遺は LAN エミュレーションのプロトコルスタックである。LAN エミュレーションは LAN 端末の MAC レイヤに位置していることがわかる。LAN エミュレーションはネットワークレイヤプロトコル種別に依存しない。

### 1.2 LAN エミュレーションの範囲

#### 1.2.1 対象となる LAN

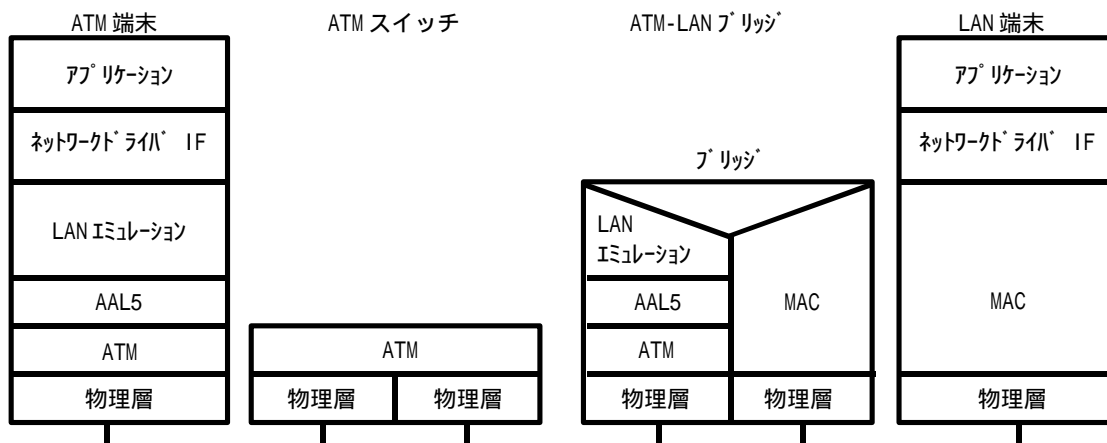
エミュレーテッド LAN のタイプは、IEEE802.3/イーサネット\*、IEEE802.5 または FDDI である。本文中 IEEE802.3/イーサネットまたは IEEE802.5 の双方について記述されているものは FDDI についても通常適用可能である。ただし、単一のエミュレーテッド LAN に複数のタイプを共存させることはできない。

#### 1.2.2 規模

LAN エミュレーションは IEEE802.3/イーサネットの単一セグメント、IEEE802.5 の単一リング及び FDDI の単一リングをエミュレートする (図 1-2 / JF-AF0084.00 補遺参照)。

\* 「イーサネット」は、富士ゼロックス株式会社の登録商標です。



図 1-2 / JF-AF0084.00 補遺 LAN エミュレーションの範囲例

LAN エミュレーションを用いることで、ATM 網の中に複数のエミュレーテッド LAN を構成することができる。複数のエミュレーテッド LAN 同士がコミュニケーションするためにはルータまたはブリッジを接続する必要がある。

また、LAN エミュレーションは ATM 網の SVC、PVC、SVC/PVC 混在のどの環境でも使用できる。

## 2. LAN エミュレーション バージョン 2.0 の機能

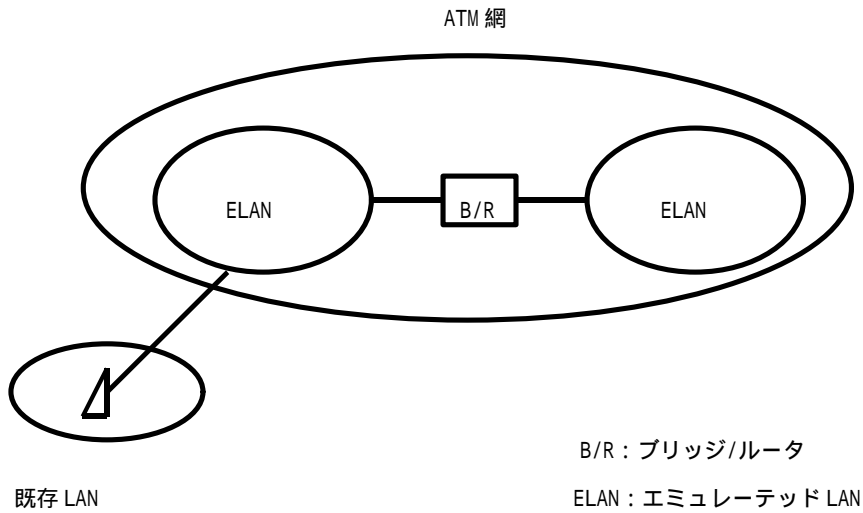
LAN エミュレーション バージョン 2.0 の主たる機能は、バージョン 1.0 と同じく、ATM 網上で従来の LAN の MAC の機能を模擬することにより、MAC フレームの転送を可能とすることである。バージョン 1.0 に比べて改善されている点は QoS(Quality of Service)をよりきめ細かくサポートすることや、マルチキャスト機能の強化、あるいは LLC 多重化を可能としたことなどであり、これに伴ってフレームフォーマットが変更されている。以下にこれらの点を解説する。

### 2.1 LAN エミュレーション バージョン 1.0 との差異

#### 2.1.1 QoS のサポート

LAN エミュレーション バージョン 2.0 では、ATM 網に接続されたエンドシステム間の通信のために、ローカルに管理される QoS を提供する。

LAN エミュレーションにおいて、QoS の働きは“Qos Sets”と“Qos Bindings”二つの言葉で定義される。QoS Sets は“qos\_handle”というパラメータで識別されるシグナリング情報要素の集まりであり、QoS Binding は QoS Set を特定の VCC へリンクすることである。LEC は、上位層が QoS を指定するためのインタフェースを提供する。

LE\_QOS\_DEFINE.request:このプリミティブは上位層が QoS Set を生成するために使用され、LEC は自身に定義されている全ての QoS Set に対してユニークなパラメータとなる qos\_handle を返す。

LE\_QOS\_UNDEFINE.request:このプリミティブは上位層がある QoS Set を削除するために使用される。

LE\_QOS\_ERROR.indication:このプリミティブは指定された qos\_handle が正しくないことを上位層に通知するために使用される。

LE\_UNITDATA.request:このプリミティブはデータ転送を要求するために使用されるが、ここで、qos\_handle を指定することによりデータ転送に使用するべき QoS Set を LEC に通知する。

もし qos\_handle が指定されなければ LEC はデフォルトの QoS Set を使う。

LAN エミュレーション QoS サービスは以下の手順で使用される。

1. 上位層は一つまたは複数の QoS Set を生成する。
2. データフレームが LEC に渡された時、LEC は選択された QoS Set とデータフレームを送信すべき先 ATM Address へ接続されている VCC との QoS Binding がすでに存在するかどうかを調べる。存在すればその VCC がデータフレームの転送のために選択される。
3. 対応する QoS Binding が存在しない場合、指定された QoS Set の要求を満たしている VCC を探す。適切な VCC が存在すればその VCC がデータフレームの転送のために選択され、その VCC と QoS Set をリンクする QoS Binding が生成される。
4. 適切な VCC が存在しない場合、LEC はシグナリング処理を起こし適切な VCC を生成する。LEC は特別な QoS 要求を持つデータ転送を可能にするために、同じユニキャスト LAN に対して複数のデータダイレクト VCC を確立できる。SETUP メッセージのための QoS に関するシグナリング情報要素は QoS Set から得られる。生成された VCC がデータフレーム転送のために選択され、QoS Set とリンクされる。
5. 最終的に適切な VCC が選択されなかった場合は、データフレームは適切な VCC が生成されるまで保持されるか、廃棄されるか、BUS へ送信される。
6. QoS Set が上位層により削除される時、LEC はその QoS Set に対応する全ての QoS Binding を削除する。また、VCC が解放される時リンクされている QoS Binding は削除される。

## 2.1.2 マルチキャスト機能の強化

### 2.1.2.1 概要

LAN エミュレーション バージョン 2.0 は、マルチキャストトラフィックを一般的なブロードキャストパスとは分離する機能を提供する。プロトコルメカニズムは、どのエミュレーテッド LAN メンバーがマルチキャストフレームを受信する必要があるかを決定するために提供される(すべてのエミュレーテッド LAN メンバーがマルチキャストフレームを受信する必要がないため)。

### 2.1.2.2 LUNI 要求事項

各フェーズにおける LUNI 要求事項では、以下の内容が追加されている。

#### (1)初期化

LEC が、特定のマルチキャスト MAC アドレスを受け取るために登録するかどうかの宣言を行うこと

#### (2)登録

LEC が受け取っているマルチキャスト MAC アドレスのリストの通知

#### (3)アドレス解決

特定のマルチキャスト MAC アドレスを扱う LE サービスを表す ATM アドレスを取得すること

#### (4)データ転送

マルチキャスト/ブロードキャスト/ユニキャストトラフィックのフィルタリング

### 2.1.2.3 LAN エミュレーションエンティティの機能

各 LAN エミュレーションエンティティの機能として、以下の内容が追加されている。

#### (1)LES

LEC は、1 つの LES にのみ接続され、LEC は、自身の LAN へ先や受信を希望するマルチキャスト MAC アドレスを LES に登録することができる。

#### (2)BUS

BUS は、複数の VCC 上で特定のマルチキャスト MAC アドレスのフレームの受信、送信をサポートするために、複数のインタフェースを持つことができる。

LEC は、すべてのマルチキャスト MAC アドレスのフレームを受信する必要がない場合、初期化時に LES に通知してもよい。

LES は、要求している LEC にのみ選択的にマルチキャスト MAC アドレスフレームを転送してもよい。

LEC は、BUS の複数インタフェースを利用し、特定マルチキャスト MAC アドレス向けフレームをブロードキャストアンノウンフレームと異なる BUS インタフェースに送信する。

### 2.1.2.4 コネクション

#### (1)マルチキャストセンド VCC

マルチキャストセンド VCC が、デフォルトマルチキャストセンド VCC とセレクトティブマルチキャストセンド VCC に分けられている。

デフォルトマルチキャストセンド VCC は、BUS に対するブロードキャストデータ送信時及び他のユニキャスト/マルチキャスト送信先に対する初期データ送信時に使用される VCC である。

セレクトティブマルチキャストセンド VCC は、特定のマルチキャスト MAC アドレス向けのマルチキャストデータ送信に使用される VCC である。

### 2.1.2.5 初期化プロトコル

マルチキャストフォワード VCC 受付時、LEC は、マルチキャストフォワード VCC 設定時の発信者識別子に



含まれる(可能性がある)ATMアドレスの妥当性をLE\_VERIFYプロトコルにより確認することが可能である。

#### 2.1.2.6 ベリファイプロトコル

LECがBUS ATMアドレスの妥当性をチェックするためのプロトコルとして追加された。

##### (1) ベリファイプロトコル概要

ベリファイプロトコルフレームには以下の2つのタイプがある。

LE\_VERIFY\_REQUEST: LECからLESに対して送信され、LESが指定されたATMアドレスの妥当性をチェックするための要求フレームである。

LE\_VERIFY\_RESPONSE: LESからLECに対してLE\_VERIFY\_REQUESTの応答として送信され、LE\_VERIFY\_REQUESTで指定されたATMアドレスの受付/拒否結果を返すフレームである。

##### (2) ベリファイプロトコルの動作

LECはLESとの間で確立したコントロールダイレクトVCCを使用し、LE\_VERIFY\_REQUESTを送信し、LE\_VERIFY\_RESPONSEを受信することで、BUSのATMアドレスの確認を行う。これらの制御情報の送信用にLESはコントロールディストリビュートVCC(オプション)を使用してもよい。



図 2-1 / JF-AF0084.00 補遺 ベリファイプロトコルの例

##### 手順

LEC1はLE\_VERIFY\_REQUESTを送信する。

LESはコントロールダイレクトVCCかコントロールディストリビュートVCC(オプション)のどちらかを用いてLE\_VERIFY\_RESPONSEで応答する。

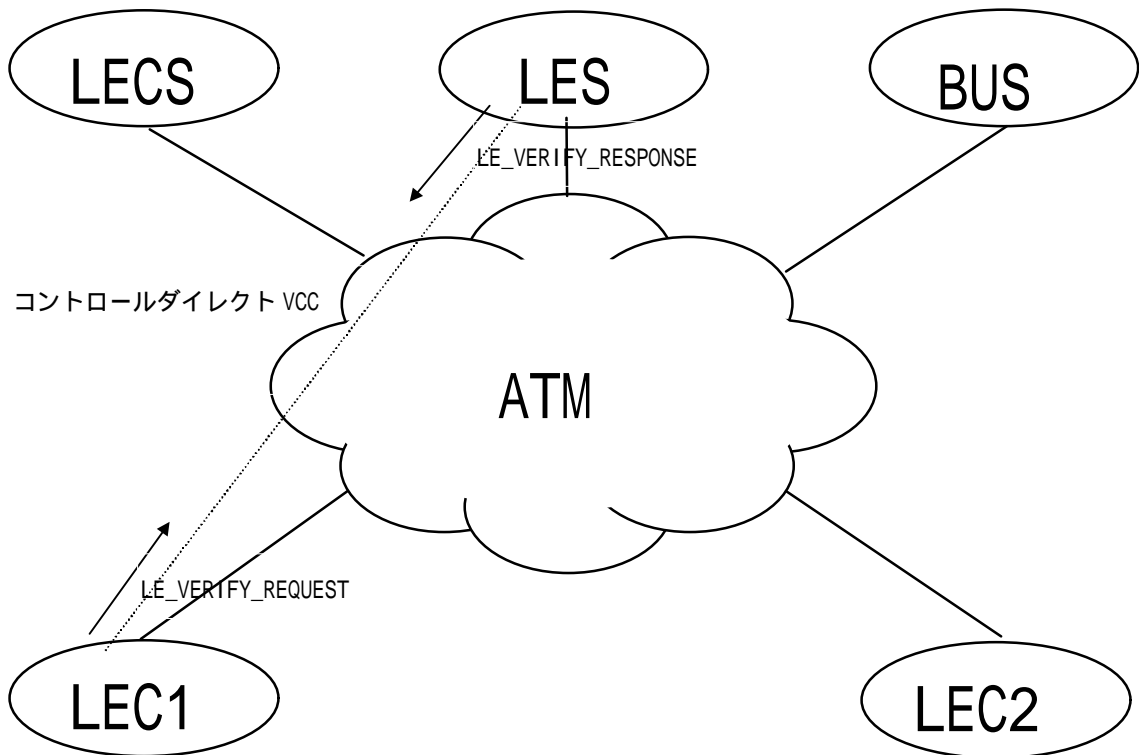
### 2.1.3 LLC 多重化

LLC 多重化のサポートは、LAN エミュレーション バージョン 2.0 の特徴のひとつである。LLC 多重化とは単一の VCC 中に複数のフローを共存させるための技術で、各データユニットを LLC/SNAP 型のカプセル化を行うことにより、LLC/SNAP ヘッダに含まれる情報からデータユニットの種別、すなわち“フロー”を識別するものである。LLC 多重された VCC は、複数の LAN エミュレーションフローを取り扱うことが可能であり、ATM ブリッジ/ルータなどのエッジデバイスのように、複数の LEC が単一の ATM インタフェースを共有する場合には、ATM リソースを効率的に使用できるようになる。また他のプロトコルのトラフィックも同時に転送可能なため、VCC 削減によるシステム規模の拡張性の面でもメリットがある。また、ATM 網上に LAN を構築するための技術である MPOA(Multiprotocol Over ATM)も LLC 多重化をデフォルトでサポートしており、LAN エミュレーション バージョン 2.0 が LLC 多重化をサポートしたことにより MPOA との整合性が向上している。

LLC 多重化が可能なのは、データダイレクトフローに対してのみであり、他のフローについては多重化することはできない。LLC 多重の VCC を用いるか、あるいは非多重の VCC を用いるかの情報交換はアドレス解決時になされる。他の LEC の ATM アドレスを得るための LE\_ARP\_REQUEST ( LE\_ARP\_RESPONSE ) 中の SOURCE-ATM-ADDRESS ( TARGET-ATM-ADDRESS ) フィールドを用いる LEC は、非多重のデータダイレクト VCC を確立する。同じく、LLC-Muxed-ATM-Address TLV を用いるものは LLC 多重データダイレクト VCC を確立する。これらの VCC は、確立時の SETUP メッセージ中の情報要素でも非多重か、LLC 多重かが判断できる ( 3.4.1.2 参照 )。また、LEC は、同一の相手先 LEC に対し複数の VCC を設定することが可能であり、それぞれの VCC についてきめ細かく QoS を設定することで、様々なアプリケーションに対し柔軟に対応することも可能となる。ただし、バージョン 1.0 と 2.0 の混在環境において、バージョン 1.0 の LEC とバージョン 2.0 の LEC 間にデータダイレクトフローを確立する場合には、LLC 多重を用いることはできないので注意が必要である。

### 2.1.4 フレームフォーマット

フレームフォーマットでは、以下の内容が追加されている。詳細については 5 章を参照のこと。

#### (1) LE データフレーム

LLC ( 3 オクテット )、OUI(Organizationally Unique Identifier) ( 3 オクテット )、フレームタイプ ( 2 オクテット )、ELAN-ID ( 4 オクテット ) よりなる 12 オクテットのヘッダを付与した、LLC 多重化フォーマットが追加されている。

#### (2) LE コントロールフレーム

LLC 多重化フォーマットの追加及び、FLAG 値、状態表示の定義内容の追加がなされている。

## 2.2 MPOA からの要求事項

LAN エミュレーションの主たる機能は、従来の LAN の MAC の模擬である。従って、LAN エミュレーションによって ATM 上に構成される LAN は、単一のネットワーク（サブネットワーク）であり、ルーティングの機能は含んでいない。

一方、The ATM Forum が仕様化した MPOA は、同じく ATM 網上に LAN を構築するための技術であるが、ルーティングの機能を有する。

MPOA 仕様はサブネットワーク内の通信に LAN エミュレーションを使用する。LAN エミュレーションは MPOA 仕様の構成要素のひとつである。

MPOA が要求する LAN エミュレーションはバージョン 2.0 の最小構成、すなわち、LAN エミュレーションバージョン 2.0 仕様で、必須とされている事項のみをサポートする LAN エミュレーションである。バージョン 1.0 にくらべて追加された機能のうち、必須であるのは、いくつかの新規のコンフィグレーション変数及び TLV (Type/Length/Value) のサポート、LE\_ARP の処理中で扱われる TLV にアクセスするための上位インターフェースを提供することなどである。

## 2.3 LAN エミュレーション バージョン 1.0 とのコンパチビリティ

LAN エミュレーション バージョン 2.0 は、バージョン 1.0 とコンパチブルではない。しかしながら、これらのクライアント、サーバコンポーネントを混在して運用することは不可能ではない。

### 2.3.1 バージョン 2.0 クライアントとバージョン 1.0 サービスコンポーネント

バージョン 2.0 の LE クライアントとバージョン 1.0 のサービスコンポーネントを相互運用する場合、たとえば選択的マルチキャスト機能の要求など、バージョン 1.0 サービスコンポーネントが違反と判断するような挙動を取らぬように、バージョン 2.0 のクライアント側に工夫を施す必要がある。

この環境でバージョン 2.0 のクライアント同士は、LE\_REGISTER\_REQUEST あるいは LE\_ARP\_RESPONSE に適当な TLV を埋め込むことによって、情報が交換できる可能性がある。

情報が交換できれば、バージョン 2.0 のクライアント同士の間でのユニキャストデータ転送ではバージョン 2.0 の機能が使用できる。

### 2.3.2 バージョン 1.0 クライアントとバージョン 2.0 サービスコンポーネント

バージョン 2.0 のサービスコンポーネントには、バージョン 1.0 の LE クライアントをサポートすることが必須とされている。従って、バージョン 1.0 クライアントとバージョン 2.0 サービスコンポーネントの相互運用は問題ない。

### 2.3.3 バージョン 1.0 クライアントとバージョン 2.0 クライアント

この場合も、バージョン 2.0 のクライアントはバージョン 1.0 のクライアントが違反と判断するような挙動を取らないようにする必要がある。バージョン 2.0 のクライアントはバージョン 1.0 のクライアントとのユニキャストのデータ転送で、LLC 多重を用いてはならない。

### 3. 構成

LAN エミュレーションは、クライアントである LE クライアント(LEC)と、サーバである LE サーバ(LES)、ブロードキャストアンノウンサーバ(BUS)、LE コンフィグレーションサーバ(LECS)からなるクライアントサーバ系のサービスである。

#### 3.1 エンティティ

LAN エミュレーションの構成図を図 3-1 / JF-AF0084.00 補遺 LAN エミュレーション構成に示す。

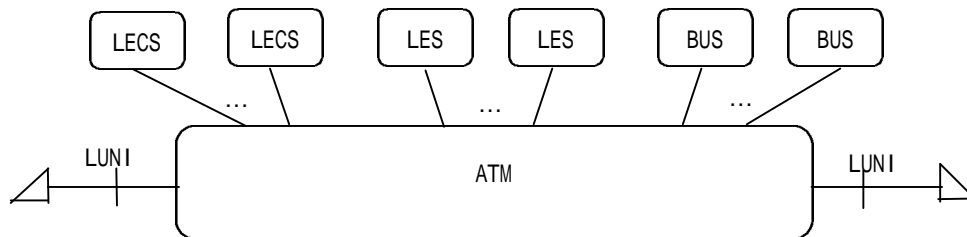

LEC : LE クライアント

LES : LE サーバ

BUS : ブロードキャストアンノウンサーバ

LECS : LE コンフィグレーションサーバ

LUNI : LAN エミュレーション UNI

(LEC と LAN エミュレーションサービスとのインタフェースであり、  
インタフェース要求条件には、初期化、登録、アドレス解決、データ転送がある)

図 3-1 / JF-AF0084.00 補遺 LAN エミュレーション構成

図 3-1 / JF-AF0084.00 補遺 LAN エミュレーション構成に示すように、LAN エミュレーションは以下の 4 種類のエンティティより構成される。

#### (1) LEC (LAN Emulation Client)

LEC はデータ転送、アドレス解決を実行し、上位レイヤに対して IEEE802.3/イーサネットあるいは IEEE802.5 サービスインタフェースをエミュレートした MAC レベルを提供し、単一のエミュレーテッド LAN 内でエンティティ間通信を行う際の LAN エミュレーション UNI(LUNI)を実現する。

#### (2) LES (LAN Emulation Server)

LES はエミュレーテッド LAN の制御機能を実装する。LES は、登録機能及び、ユニキャスト及びマルチキャスト MAC アドレスやルートディスクリプタから ATM アドレスを解決する機能を提供する。1 つの LEC は、1 つの LES にも結合される。LEC は自身を表す LAN 内で先や自身が受信を希望するマルチキャスト MAC アドレスを LES に対して登録可能である。LEC は MAC アドレスやルートディスクリプタから ATM アドレスを解決したい場合、LES にお問い合わせすることになる。LES は直接 LEC に応答するか、他の LEC へ問い合わせを転送する。

#### (3) BUS (Broadcast and Unknown Server)

BUS は、LEC より転送されるブロードキャスト MAC アドレスのデータ、マルチキャストデータ及び、ATM アドレスが解決される以前(LEC 間でデータダイレクト VCC が確立される以前)のユニキャストデータを他の LEC に分配する。

BUS では、1 つの MAC フレームに対応する ATM セルの転送中に他の MAC フレームに属するセルが混入する状況の発生を防ぐために、1 つの MAC フレームに属するセルの送出を完結させた後に、次の MAC

フレームの転送を開始するようになる必要がある。

BUS は、複数の VCC に対し特定のマルチキャスト MAC アドレスフレームの受信/転送を可能とするインタフェースを提供する。このインタフェースは複数であってもよい。

LEC は、全てのマルチキャスト MAC アドレスフレームを受信する必要がない場合、初期化時に LE サービスに対し通知してもよい。

LE サービスは、転送を要求している LEC のみに対し、選択的にマルチキャスト MAC アドレスフレームを送信する。

LEC は、異なる BUS インタフェースを利用し、ブロードキャストアンノウンフレームの送信(デフォルトマルチキャストセンド VCC)と特定のマルチキャスト MAC アドレスフレームの送信(セレクトティブマルチキャストセンド VCC)を区別してもよい。

#### (4) LECS(LAN Emulation Configuration Server)

1 つあるいは複数の LECS は、コンフィグレーションデータベース及びクライアントより提供される情報をもとに、適切な LES の ATM アドレスを提供することにより、コンフィグレーション情報を要求するクライアントを個々のエミュレーテッド LAN に割り当てる。

全ての LEC は、コンフィグレーションプロトコルにより LECS から情報を獲得可能でなければならない。

### 3.2 コネクション

LAN エミュレーション バージョン 1.0 では非多重の VCC のみをサポートするのに対し、LAN エミュレーション バージョン 2.0 では LLC 多重の VCC サポートが追加される。LLC 多重の VCC は、1 つあるいは複数の LAN エミュレーションフローのトラヒック及び、他のプロトコルトラヒックを転送する。ある LAN エミュレーションフローはデータや単一の ELAN のために選択される制御トラヒックから成っており、非多重の VCC では 1 つのフローのみを転送する。LAN エミュレーション バージョン 1.0 は非多重の VCC のみをサポートするため、フローと VCC という用語を同義のものとして取り扱う。

マルチキャストフォワード及びコントロールディストリビューションフローは、ポイント・マルチポイント VCC 上を転送される。データダイレクト、コンフィグレーションダイレクト、デフォルトマルチキャストセンド及びセレクトティブマルチキャストセンドフローは、ポイント・ポイント VCC 上を転送される。

LLC 多重が可能なのはデータダイレクトフローのみであり、他の全てのフローは多重化不可能である。

LAN エミュレーション バージョン 2.0 では、ある特定の LEC という観点から、データダイレクト VCC という用語をある特定のデータダイレクトフローを転送する VCC を意味するものとして使用する。LLC 多重のデータダイレクト VCC は、LLC 多重をサポートする他のプロトコルだけではなく、複数の LEC によっても共有可能である。

LAN エミュレーションコンポーネントはフローを設定することを必要とする。所望の ATM アドレスに対し、既に LLC 多重の VCC が確立されている場合、新しいフローはその VCC 上に設定可能である。一方適切な VCC が確立されていないか、確立中である場合、新しい VCC を確立しなければならない。この新しい VCC は、他のプロトコル要求に従い、LLC 多重または非多重のどちらでもよい。

非多重 VCC 上のフローがターミネートされる場合は、必ずその VCC は解放される。LLC 多重 VCC 上のフローがターミネートされる場合は、その VCC 上のフローが 0 になるまで VCC は解放されない。

図 3-2 / JF-AF0084.00 補遺 フロー例に LECS、LES、BUS、2 つの LEC がある構成での LUNI のフロー例を示す。



図 3-2 / JF-AF0084.00 補遺 フロー例

以下にフローと VCC の詳細を示す。

(1) 制御フローと VCC

- コンフィグレーションダイレクト VCC

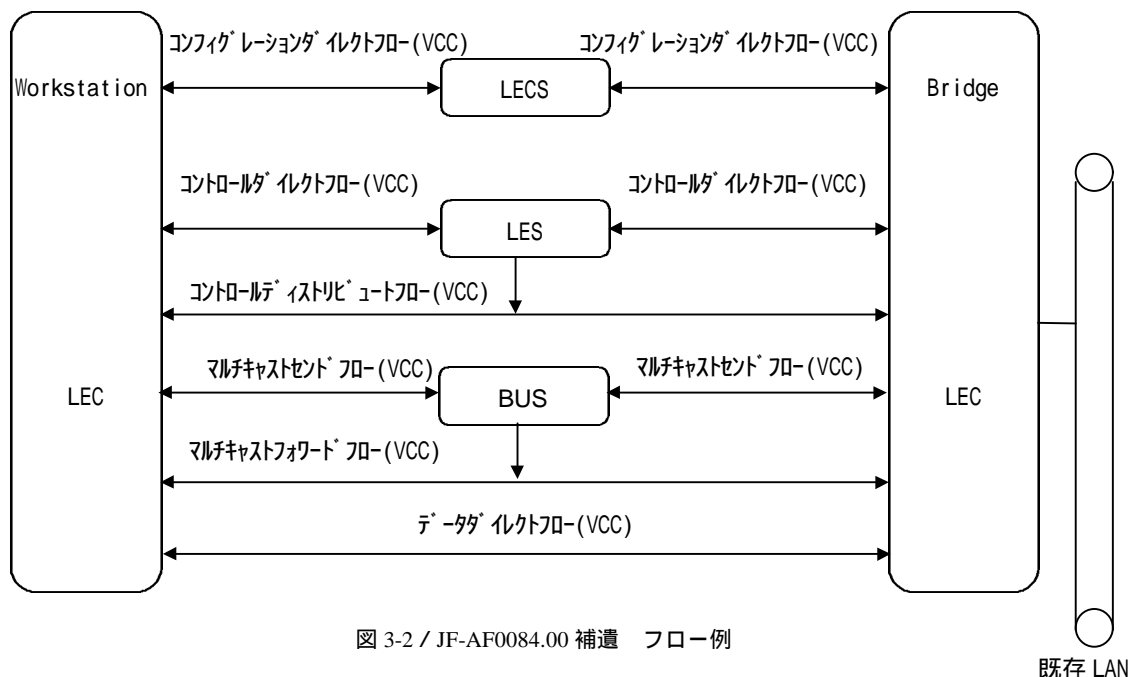
LECS 接続フェーズ中に LEC(または他のエンティティ)より確立する双方向ポイント・ポイント VCC であり、LECS より LES のアドレスを含むコンフィグレーション情報を獲得するために使用する。

- コントロールダイレクト VCC

初期化フェーズ中に LEC より設定する双方向ポイント・ポイント VCC であり、LEC が LES に制御トラヒックを送信するために使用する。

LES はこの VCC からの制御トラヒックを受信可能であることが要求される。

LEC と LES はエミュレーテッド LAN に属している間、この VCC を保持する必要がある。

- コントロールディストリビュート VCC

オプションとして、初期化フェーズ中に LES より設定されるポイント・マルチポイント VCC であり、LES からの制御トラヒックを LEC に分配するために使用する。

コントロールディストリビュート VCC が確立される場合、LEC はこの VCC を受信可能であることが要求される。

LEC と LES はエミュレーテッド LAN に属している間、この VCC を保持する必要がある。

(2) データフローと VCC

- データダイレクト VCC

LEC 間に確立される双方向ポイント・ポイント VCC であり、ユニキャストデータトラヒックの転送に使用する。

LEC はあて先の ATM アドレスが分からない場合、LE\_ARP 要求を送信し、その応答で指定された ATM アドレスに対してデータダイレクト VCC を確立するためのシグナリングを実行する。もし、LEC がデータダイレクト VCC 確立のためのリソースを持っていない場合、既に確立されている他の LEC へのデータダイレクト VCC を解放させ、新たなデータダイレクト VCC を確立すべきである。

LEC は、コネクションレス型のインタフェースに加えて、特定の QoS を持つ付加的なデータダイレクト VCC を確立することにより、高位レイヤに対してコネクション型のインタフェースを提供することが可能である。

データダイレクト VCC は非多重または LLC 多重のどちらでもよい。

- マルチキャストセンド VCC

LEC より確立する双方向ポイント・ポイント VCC であり、この VCC は、データダイレクト VCC と同様の手順により確立される。この VCC は非多重でなければならない。

BUS に対するブロードキャストデータ送信、初期時のユニキャスト/マルチキャストデータ送信に使用される VCC をデフォルトマルチキャストセンド VCC と呼ぶ。一方、オプションとしてある特定のマルチキャスト MAC アドレスあてのマルチキャストデータ送信に使用される VCC をセレクトティブマルチキャストセンド VCC と呼ぶ。

BUS が、LEC へのデータを送信するためにこの VCC のリターンパスを用いるかもしれないことから、LEC はこの VCC からのデータを受信可能であることが要求される。

LEC はエミュレーテッド LAN に属している間、少なくともデフォルトマルチキャストセンド VCC を保持する必要がある。

- マルチキャストフォワード VCC

BUS より LEC に対して確立するポイント・マルチポイント VCC であり、BUS からのデータを LEC に分配するために使用する。

デフォルトマルチキャストセンド VCC 確立後、BUS は最初のマルチキャストフォワード VCC を確立する。それ以降、BUS はいつでも付加的なマルチキャストフォワード VCC を確立可能である。LEC は、マルチキャストフォワード VCC を受け付けることが要求される。

LEC はエミュレーテッド LAN に属している間、マルチキャストフォワード VCC を保持する必要がある。

BUS は、マルチキャストセンド VCC またはマルチキャストフォワード VCC のどちらかを使用して LEC へフレームを転送する。LEC は、どちらの VCC でもフレーム受信可能であることが要求される。

### 3.3 レイヤアーキテクチャ

図 3-3 / JF-AF0084.00 補遺 レイヤアーキテクチャに LAN エミュレーションのレイヤアーキテクチャを示す。

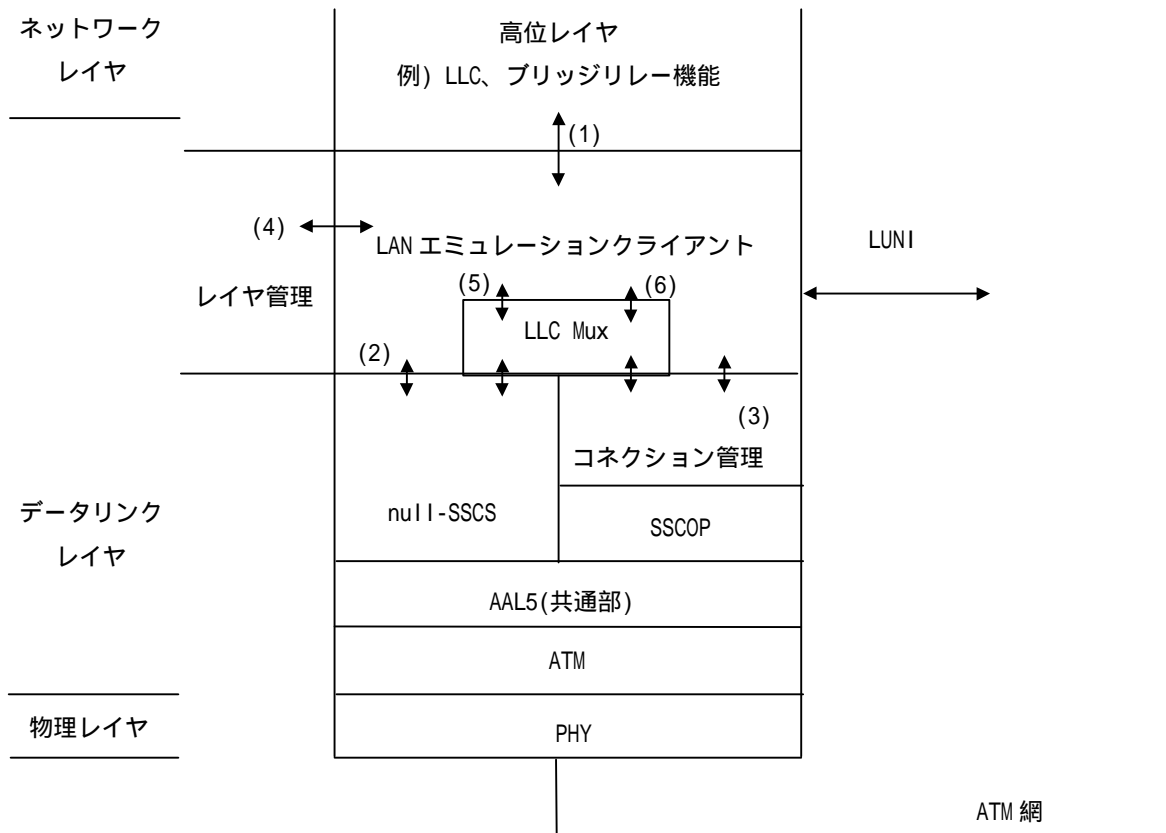

SSCS : CS サービス依存部

SSCOP : サービス依存部コネクション型プロトコル

図 3-3 / JF-AF0084.00 補遺 レイヤアーキテクチャ

以下にレイヤ間インタフェースの要求事項を示す

- (1) LAN エミュレーションレイヤと高位レイヤ間のインタフェースは、ユーザデータフレームの送信/受信のための機能を含む。
- (2) LAN エミュレーションレイヤと ATM アダプテーションレイヤ間のインタフェースは、AAL5 フレームの送信/受信のための機能を含む。AAL5 は ATM 及び PHY を含むより低位のレイヤを利用する。インタフェースサービスアクセスポイントは SAP-ID により識別される。
- (3) LAN エミュレーションレイヤとコネクション管理エンティティ間のインタフェースは、非多重の VCC の確立 / 解放のための機能を含む。
- (4) LEC とレイヤ管理エンティティ間のインタフェースは、LEC の初期化、制御する機能、状態情報を返す機能を含む。
- (5) LEC と LLC Mux エンティティ間のインタフェースは、LLC 多重フレームの送信 / 受信のための機能を含む。このインタフェースは、LAN エミュレーション バージョン 2.0 以外のエンティティと VCC を共用可能な LLC 多重フローのために使用される。このインタフェースの定義は LAN エミュレーション バージョン 2.0 の範囲外である。
- (6) LEC と LLC Mux エンティティ間のインタフェースは、LLC 多重フローの確立 / 解放のための機能を含む。このインタフェースは、LAN エミュレーション バージョン 2.0 以外のエンティティと VCC を共用可能な LLC 多重フローのために使用される。このインタフェースの定義は LAN エミュレーション バージョン



2.0の範囲外である。

### 3.4 共通技術

ここでは4章で解説されるLANエミュレーション動作の各フェーズで共通に用いられる技術であるコネクションの確立及びアドレス解決について予め解説する。

#### 3.4.1 コネクションの確立

##### 3.4.1.1 各フェーズにおけるコネクション

LANエミュレーションにおいては、LECとサーバ群またはLEC同士で情報転送が行われる。これらの情報転送のためにはコネクションを確立する必要がある。以下に、コネクションの種別と確立されるフェーズを示す。

表 3-1 / JF-AF0084.00 補遺 コネクション種別及び確立されるフェーズ

コンフィグレーションダイレクト VCC	LECS 接続フェーズ
コントロールダイレクト VCC	ジョインフェーズ
コントロールディストリビュート VCC	ジョインフェーズ
マルチキャストセンド VCC	BUS 接続フェーズ
マルチキャストフォワード VCC	BUS 接続フェーズ
データダイレクト VCC	ユニキャストデータ転送(Direct)

##### 3.4.1.2 コネクションタイプ

LANエミュレーションでは、コネクションを確立する際のSETUPメッセージ中の広帯域低位レイヤ情報(B-LLI: Broadband Low Layer Information)により、5つのタイプの非多重コネクションと、LLC多重コネクションとを識別している。

非多重コネクションのタイプ1はLANエミュレーション制御プロトコルを転送するものである。非多重コネクションの残りの4つのタイプは、IEEE802.3/イーサネット及びIEEE802.5でフォーマットされたデータを転送するものである。

表 3-2 / JF-AF0084.00 補遺 コネクションタイプ

B-LLI フィールド	値	コネクションタイプ	
PID	0001	非多重 コネクション	コンフィグレーションダイレクト VCC
			コントロールダイレクト VCC
			コントロールディストリビュート VCC
			IEEE802.3/イーサネットデータダイレクト VCC
			IEEE802.5 データダイレクト VCC
	0002		IEEE802.3/イーサネットマルチキャストセンド VCC
			IEEE802.3/イーサネットマルチキャストフォワード VCC
	0003		IEEE802.5 マルチキャストセンド VCC
			IEEE802.5 マルチキャストフォワード VCC
	0004		IEEE802.3/イーサネットマルチキャストセンド VCC
			IEEE802.3/イーサネットマルチキャストフォワード VCC
	0005		IEEE802.5 マルチキャストセンド VCC
			IEEE802.5 マルチキャストフォワード VCC
User information layer 2 protocol	12	LLC 多重 コネクション	データダイレクト VCC

### 3.4.1.3 コネクションの確立/解放の概要

コネクションの確立の機能はコネクションマネジメントエンティティのサービスを用いる。コネクションマネジメントは、PVC、SVC、SVC/PVCの混在環境下でサービスを提供する。PVCでは、固定的にコネクションが確立されているため、呼設定と呼切断がない。SVCでは、必要に応じてコネクションが動的に確立されるため有効なリソースの利用と最適な経路の選択が可能であり、呼設定と呼切断が存在する。このSVCの確立/解放のために、コネクションマネジメントはUNIシグナリングプロトコルを用いる。The ATM Forumでは、UNIシグナリングプロトコルをUNI仕様3.0/3.1及びSIG4.0で規定している。

SVCにおいて、コネクションマネジメントは、コネクションの確立のためのSETUP、エンド・エンドコネクションを解放するためのRELEASE、既存のコネクションへの加入のためのADD PARTY、既存のポイント・マルチポイントコネクションからの離脱のためのDROP PARTYの各サービスを行う。

コネクションの確立/解放の概要は以下の通りである。

#### (1) コネクションの確立

発信ユーザは呼設定要求のためのSETUPメッセージを送信する。スイッチはSETUPメッセージを受信し、コネクションを確立する。スイッチからCALL PROCEEDINGメッセージが返送される場合がある。

コネクションが確立される時、着ユーザは、VCC上でのフレーム受信の準備が整うまでCONNECTメッセージを送出することができない。即ち、発信ユーザでは、CONNECTメッセージを受信した後ならばフレームを送信可能であると判断することができる。

着ユーザが受信するCONNECT ACKNOWLEDGEメッセージは、発信ユーザからではなく、スイッチから送信される。CONNECT ACKNOWLEDGEメッセージは、発信ユーザがCONNECTメッセージを受信する前に、着ユーザによって受信される場合がある。発信ユーザでは割り当てられたVPI/VCIを示しているCONNECTメッセージの受信後にフレーム受信のための確立を行うことが可能となるため、発信ユーザがこのCONNECTメッセージを受信するまで、着ユーザからのデータは保証されない。READYプロトコルは、発信ユーザがフレーム受信の確立が完了したことを着ユーザに通知するための手順である。



図 3-4 / JF-AF0084.00 補遺 コネクションの確立

- \*1 発信ユーザは、受信準備完了後、READY\_IND を送出しなければならない。また、READY\_IND 送出前にデータフレーム(またはフラッシュフレーム)を送出してよい。
- \*2 着ユーザは、READY\_IND 受信前に有効なデータフレーム(またはフラッシュフレーム)を受信した時点で、C28 タイマを停止させてよい。
- \*3 着ユーザが READY\_IND 受信前に送出したデータフレームは、発信ユーザが受信できないかもしれない。
- \*4 着ユーザが READY\_IND 受信後に送出したデータフレームは、発信ユーザで受信可能。
- \*5 READY\_QUERY を受信した LEC は、直ちに READY\_IND で応答しなければならない。

(2) コネクションの解放

RELEASE メッセージを発信ユーザが送信する。これにより、スイッチはコネクションの解放を行い、RELEASE COMPLETE メッセージを送信する。着ユーザでは、RELEASE メッセージを受信し、RELEASE COMPLETE メッセージを送信する。

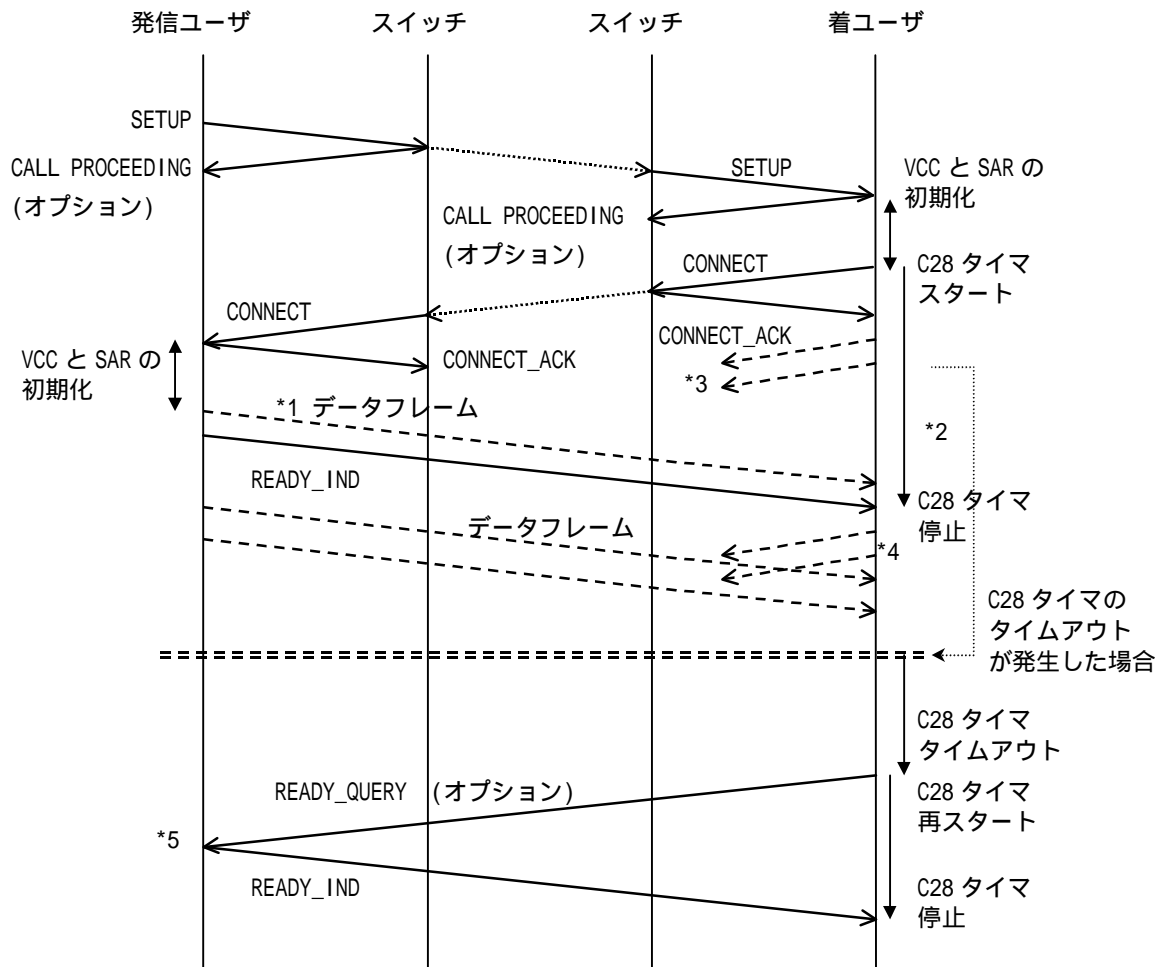
ターミネーションにおいては、全てのコネクションが解放される。



図 3-5 / JF-AF0084.00 補遺 コネクションの解放

#### 3.4.1.4 QoS サポート

LEC は、同一のユニキャスト LAN あて先に対して複数のデータダイレクト VCC を確立することが認められている。LEC は、ある特定のユニキャスト LAN あて先に関するサービスカテゴリ TLV を LES に登録することにより、その LAN あて先に対する複数のデータダイレクト VCC の SETUP 要求を受理可能であることを通知する。付加的なデータダイレクト VCC は、高位レイヤからの特定の QoS 要求を持つ片方向フロートラフィックの搬送要求時に確立される。

高位レイヤは、この機能を使用することにより、コネクション確立時に以下に示すシグナリング情報要素を指定することが認められている。ATM Forum UNI Signaling Version 4.0(SIG4.0)のみで適用可能なパラメータは、SIG4.0 のみと表記している。

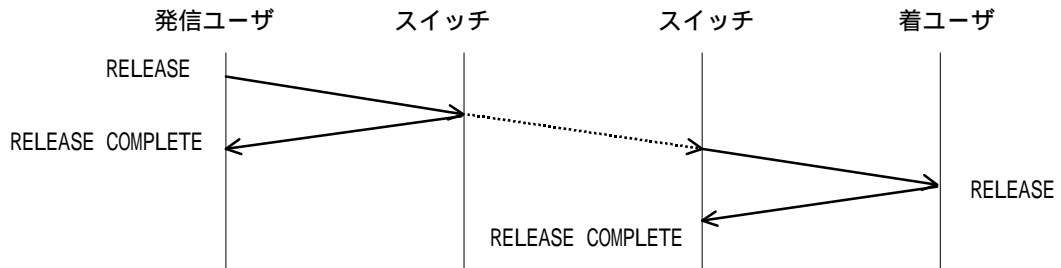
- ATM Traffic Descriptor、 Alternative Traffic Descriptor (SIG4.0 のみ)
- Minimum Acceptable ATM Traffic Descriptor (SIG4.0 のみ)
- Broadband Bearer Capability
- Extended QoS Parameters (SIG4.0 のみ)
- QoS Parameter
- End-to-End Transmit Delay (SIG4.0 のみ)
- ABR Setup Parameters (SIG4.0 のみ)
- ABR Additional Parameters (SIG4.0 のみ)

これらの情報要素に適用可能な値は、LEC が利用可能なシグナリングバージョンによって制限を受ける。また、広帯域低位レイヤ情報要素は、非多重または LLC 多重フレームのどちらも選択するために使用可能である。高位レイヤが指定しない情報要素については、LEC がデフォルト値を適用する。

高位レイヤによる QoS 指定がない場合、データダイレクト VCC に対してデフォルト QoS を指定しなければならない。デフォルト QoS は、UBR(Unspecified Bit Rate)または ABR(Available Bit Rate)、QoS クラス 0 である。

### 3.4.2 アドレス解決

クライアントは、転送すべきフレームがあると、その相手先の MAC アドレスに対応する ATM アドレスを解決する必要がある。

これを LAN エミュレーションアドレス解決プロトコルと呼ぶ。

LAN エミュレーションではアドレス解決プロトコルとして主に以下に示す 2 タイプのフレームを使用する。

LE\_ARP\_REQUEST  
LE\_ARP\_RESPONSE

#### 3.4.2.1 サーバに相手先が登録されている時のアドレス解決動作について



図 3-6 / JF-AF0084.00 補遺 サーバに相手先が登録されている場合の LE\_ARP

#### 動作

LEC1 は LE\_ARP\_REQUEST を送信する。

応答として LES は LE\_ARP\_RESPONSE を送信する。

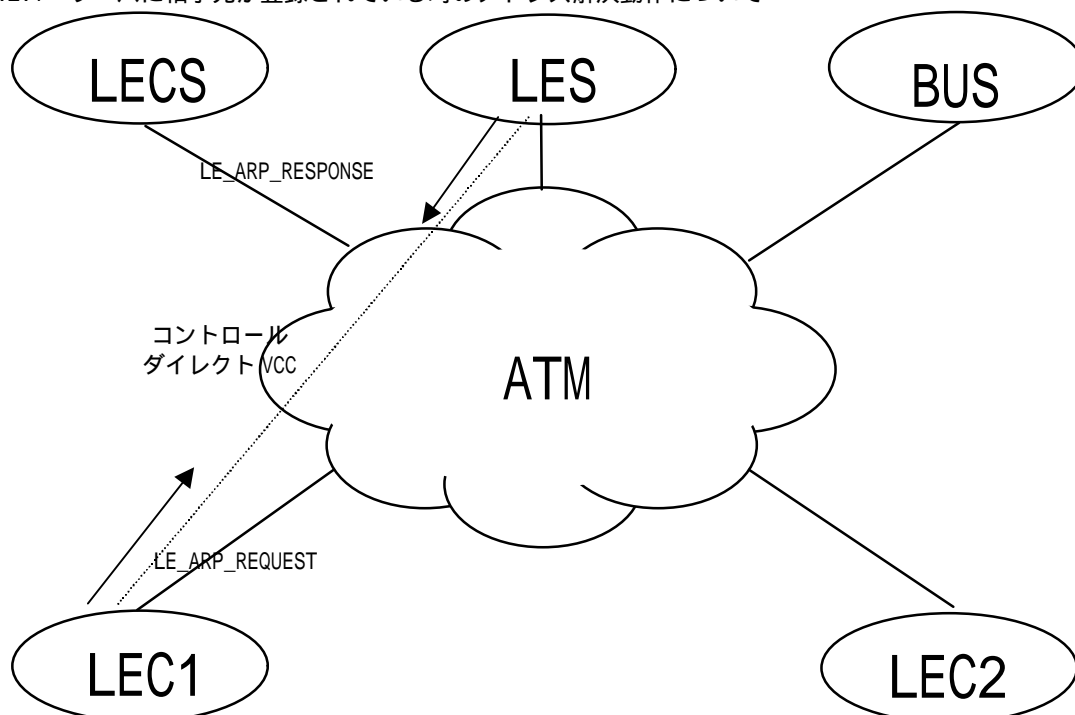
LE\_ARP\_RESPONSE を受けた LEC1 はアドレス解決された情報をキャッシュに登録する。

\* LES LEC1 はコネクションとしてコントロールディストリビュート VCC を使用してもよい。

### 3.4.2.2 サーバに相手先が登録されていない時のアドレス解決動作について



図 3-7 / JF-AF0084.00 補遺 サーバに相手先が登録されていない場合の LE\_ARP

#### 動作

LEC1 は LE\_ARP\_REQUEST を送信する。

LES は LE\_ARP\_REQUEST をすべてのプロキシを含む LEC に同報する。

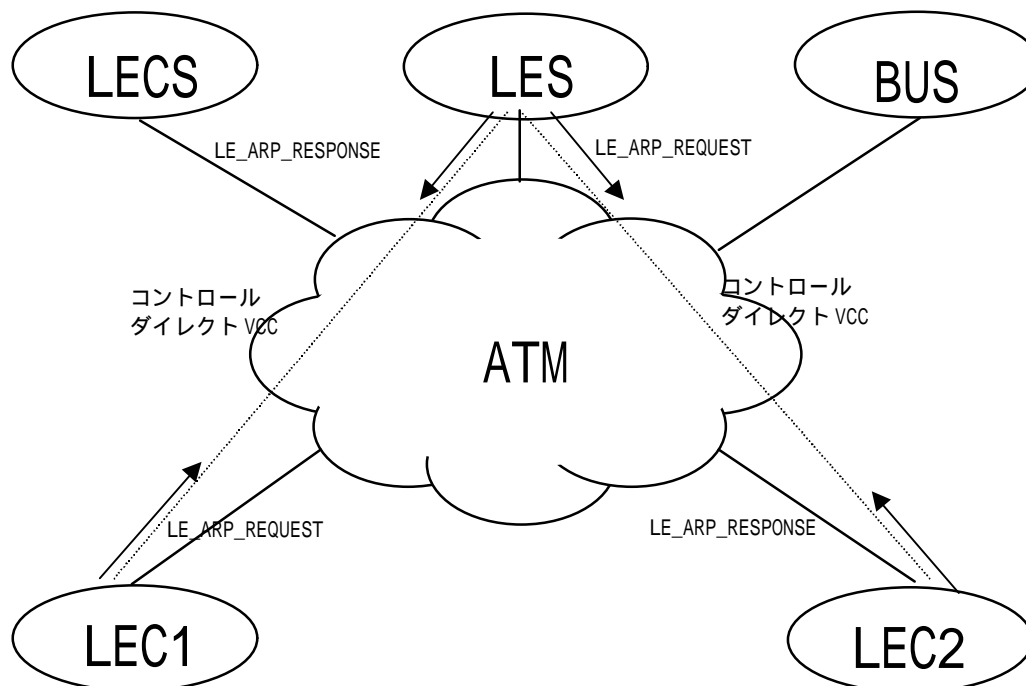
該当する LEC2 は の応答として LES に LE\_ARP\_RESPONSE を送信する。

LES は の応答として LE\_ARP\_RESPONSE を送信する。

LE\_ARP\_RESPONSE を受けた LEC1 はアドレス解決された情報をキャッシュに登録する。

\* LES LEC1 及び LES LEC2 はコネクションとしてコントロールディストリビュート VCC を使用してもよい。

### 3.4.2.3 LE\_ARP が適用される動作フェーズ

このアドレス解決動作は BUS 接続フェーズでの BUS のアドレス取得及びアドレスが解決されていない相手先へのユニキャスト及びマルチキャスト転送フェーズにおいて適用される。

### 3.4.2.4 LAN エミュレーション バージョン 2.0 の ARP における TLV の拡張

LAN エミュレーション バージョン 2.0 において LE\_ARP フレームの TLV 関連フィールドが拡張された。これに伴い ARP のシーケンスにおいて TLV の情報が交換される。

### 3.4.3 TLV

LECは、エミュレーテッド LAN に加入しアドレスの登録や解決を行う為に、LE コントロールフレームによって LES/LECS との間で各種パラメータの交換を行うが、LE コントロールフレーム中に固定的にフィールドを割り当てられているパラメータ以外にも、LAN エミュレーションでは独自の TLV(Type/Length/Value)を定義しており、LE コントロールフレーム中の可変長の TLV フィールドに TLV をマッピングすることによりパラメータの交換を行う。

表 3-3 / JF-AF0084.00 補遺に LAN エミュレーションで定義されている TLV の一覧を示す。



表 3-3 / JF-AF0084.00 補遺(1/3) LAN エミュレーションコントロールフレーム TLV

項	項 目	タイプ	データ長	説 明	使用プロトコル	バージョン
1	Max-Cumulative-Control-Time-out (最大累積コントロールタイムアウト)	00-A0-3E-01	2	<b>C7:Control Time-out</b> 制御フレームの送受に用いるタイム(単位:秒)	LE_CONFIGURE_RESPONSE (LECS から LEC に通知される)	V1
2	Max-Unknown-Frame-Count (最大アンノウンフレーム数)	00-A0-3E-02	2	<b>C10:Maximum Unknown Frame Count</b> C11 で定義された単位時間当たりに BUS に送信できるアドレス未解決フレームのフレーム数	LE_CONFIGURE_RESPONSE (LECS から LEC に通知される)	V1
3	Max-Unknown-Frame-Time (最大アンノウンフレーム時間)	00-A0-3E-03	2	<b>C11:Maximum Unknown Frame Time</b> BUS に送信できるアドレス未解決フレームを制限するための単位時間 (単位:秒)	LE_CONFIGURE_RESPONSE (LECS から LEC に通知される)	V1
4	VCC-Time-out-Period (VCC タイムアウト時間)	00-A0-3E-04	4	<b>C12:VCC Time-out Period</b> VCC を解放するための無通信監視のタイム (単位:秒)	LE_CONFIGURE_RESPONSE (LECS から LEC に通知される)	V1
5	Maximum-Retry-Count (最大リトライ数)	00-A0-3E-05	2	<b>C13:Maximum Retry Count</b> LE_ARP_REQUEST の最大リトライ回数	LE_CONFIGURE_RESPONSE (LECS から LEC に通知される)	V1
6	Aging-Time (エージングタイム)	00-A0-3E-06	4	<b>C17:Aging Time</b> LE_ARP キャッシュの保持時間 (単位:秒)	LE_CONFIGURE_RESPONSE (LECS から LEC に通知される)	V1
7	Forward-Delay-Time (フォワード遅延時間)	00-A0-3E-07	2	<b>C18:Forward Delay Time</b> LE_ARP キャッシュ内のリモート MAC アドレスの保持時間 (単位:秒)	LE_CONFIGURE_RESPONSE (LECS から LEC に通知される)	V1
8	Expected-LE_ARP-Response Time (LE_ARP 応答時間)	00-A0-3E-08	2	<b>C20:Expected LE_ARP Response Time</b> LE_ARP_REQUEST に対する LE_ARP_RESPONSE の最大応答待ち時間 (単位:秒)	LE_CONFIGURE_RESPONSE (LECS から LEC に通知される)	V1
9	Flush-Time-out (フラッシュタイムアウト)	00-A0-3E-09	2	<b>C21:Flush Time-out</b> LE_FLUSH_REQUEST に対する LE_FLUSH_RESPONSE の最大応答待ち時間 (単位:秒)	LE_CONFIGURE_RESPONSE (LECS から LEC に通知される)	V1
10	Path-Switching-Delay (パス切り換え遅延時間)	00-A0-3E-0A	2	<b>C22:Path Switching Delay</b> アドレス解決後データダイレクト VCC が接続される見込み時間 (単位:秒) (フラッシュプロトコルを使用しない場合に使用する)	LE_CONFIGURE_RESPONSE (LECS から LEC に通知される)	V1
11	Local-Segment-ID (ローカルセグメント ID)	00-A0-3E-0B	2	<b>C23:Local Segment ID</b> 12ビットのバイナリフォーマットで表される ELAN のセグメント ID. (0000SSSSSSSSSS) (LEC が IEEE802.5 のソースルーティングブリッジの場合のみ)	LE_CONFIGURE_RESPONSE (LECS から LEC に通知される) LE_JOIN_RESPONSE (LANE v2) (LES から LEC に通知される)	V1

表 3-3 / JF-AF0084.00 補遺(2/3) LAN エミュレーションコントロールフレーム TLV

項	項目	タイプ	データ長	説明	使用プロトコル	バージョン
12	Default-Mcast-Send-VCC-Type (デフォルトマルチキャストセンド VCC タイプ)	00-A0-3E-0C	2	<b>C24: Default Multicast Send VCC Type</b> デフォルトマルチキャストセンド VCC 確立時のシグナ リングパラメータ X'0000' UBR (v1/v2 共通) X'0001' VBR (v1 のみ) X'0002' CBR (v1 のみ) X'0003' VBR (v2 のみ) X'0004' CBR (v2 のみ)	LE_CONFIGURE_RESPONSE (LECS から LEC に通知される)	V1 説明欄参照
13	Default-Mcast-Send-VCC-AvgRate (デフォルトマルチキャストセンド VCC 平均レート)	00-A0-3E-0D	4	<b>C25: Default Multicast Send VCC AvgRate</b> デフォルトマルチキャストセンド VCC の平均セルレ ート (単位: セル/秒) (シグナリングパラメータ)	LE_CONFIGURE_RESPONSE (LECS から LEC に通知される)	V1
14	Default-Mcast-Send-VCC- PeakRate (デフォルトマルチキャストセンド VCC ピークレート)	00-A0-3E-0E	4	<b>C26: Default Multicast Send VCC PeakRate</b> デフォルトマルチキャストセンド VCC のピークセルレ ート (単位: セル/秒) (シグナリングパラメータ)	LE_CONFIGURE_RESPONSE (LECS から LEC に通知される)	V1
15	Connection-Completion-Timer (接続完了タイマ)	00-A0-3E-0F	2	<b>C28: Connection Completion Timer</b> コネクッション確立後、発信側から READY_IND またはデ ータフレームの最大待ち時間 (単位: 秒) (オプション)	LE_CONFIGURE_RESPONSE (LECS から LEC に通知される)	V1
16	Config-Frag-Info (コンフィグレーションフラグ情報)	00-A0-3E-10	0-255	LE_CONFIGURE フレームにおいてのみ使用される	LE_CONFIGURE_REQUEST LE_CONFIGURE_RESPONSE	V2
17	Layer-3-Address (レイヤ 3 アドレス)	00-A0-3E-11	可変	<b>C36: L3 Address</b> ISO 10747 に従ってエンコードされた LEC の レイヤ 3 アドレス	LE_CONFIGURE_REQUEST LE_JOIN_REQUEST	V2
18	ELAN-ID	00-A0-3E-12	4	<b>C31: ELAN-ID</b> LEC が参加する ELAN の ID	LE_CONFIGURE_RESPONSE (LECS から LEC に通知される) LE_JOIN_RESPONSE (LES から LEC に通知される)	V2
19	Service-Category (サービスカテゴリ)	00-A0-3E-13	2	ビット 0 rt-VBR サポート ビット 1 nrt-VBR サポート ビット 2 ABR サポート ビット 3 CBR サポート ビット 4-15 未定義 (将来使用)。	LE_REGISTER_REQUEST (LES に登録する) LE_ARP_REQUEST LE_ARP_RESPONSE (LEC がサポートしているサービ スカテゴリを通知する) LE_NARP_REQUEST	V2

表 3-3 / JF-AF0084.00 補遺(3/3) LAN エミュレーションコントロールフレーム TLV

項	項目	タイプ	データ長	説明	使用プロトコル	バージョン
20	LLC-Muxed-ATM-Address (LLC 多重 ATM アドレス)	00-A0-3E-2B	20	<b>C1n:LE Client's LLC-Multiplexed ATM Address</b> LLC 多重 VCC に対応する ATM アドレス。 要求フレームの送信元 ATM アドレスフィールド中の非多重 ATM アドレスや、応答フレーム中の宛て先 ATM アドレスと同様の機能を提供する。	LE_REGISTER_REQUEST (LES に登録する) LE_ARP_REQUEST LE_ARP_RESPONSE LE_NARP_REQUEST	V2
21	X5-Adjustment (X5 調整)	00-A0-3E-2C	0	MAXIMUM-FRAME-SIZE フィールドの X"01"と X"02"の値が 1580/1592 オクテットを意味するように変更する。LE_CONFIGURE_REQUEST "V2 Capable"フラグがセットされていない場合は設定してはならない。	LE_CONFIGURE_REQUEST LE_CONFIGURE_RESPONSE LE_JOIN_REQUEST	V2
22	Preferred-LES (優先 LES)	00-A0-3E-2D	20	<b>C35:Preferred LES Address</b> 優先 LES の ATM アドレス	LE_CONFIGURE_RESPONSE (LECS から LEC に通知される) LE_JOIN_REQUEST	V2
23	User Defined TLVs (ベンダ定義 TLV)	-	0-255	ベンダが独自に定義し、TLV を拡張することができる。タイプ値の上位3オクテットはベンダの OUI でなければならない。	LE_REGISTER_REQUEST (LES に登録する) LE_ARP_REQUEST LE_ARP_RESPONSE	V2

注 1. 表中のバージョン欄で、V1 とあるものは特に注記しない限りはバージョン 1.0、バージョン 2.0 に共通の TLV であり、V2 とあるものはバージョン 2.0 にのみ有効な TLV である。

注 2. タイプ値の上位3オクテット"00-A0-3E"は The ATM Forum の OUI を示す。

## 4. 動作

### 4.1 各フェーズの流れ

本章では、LAN エミュレーションの動作を説明する。図 4-1 / JF-AF0084.00 補遺に LAN エミュレーションの各フェーズの一般的な流れの一例を示す。異常系も含めた各フェーズの完全な流れや状態の遷移については標準本文を参照願いたい。

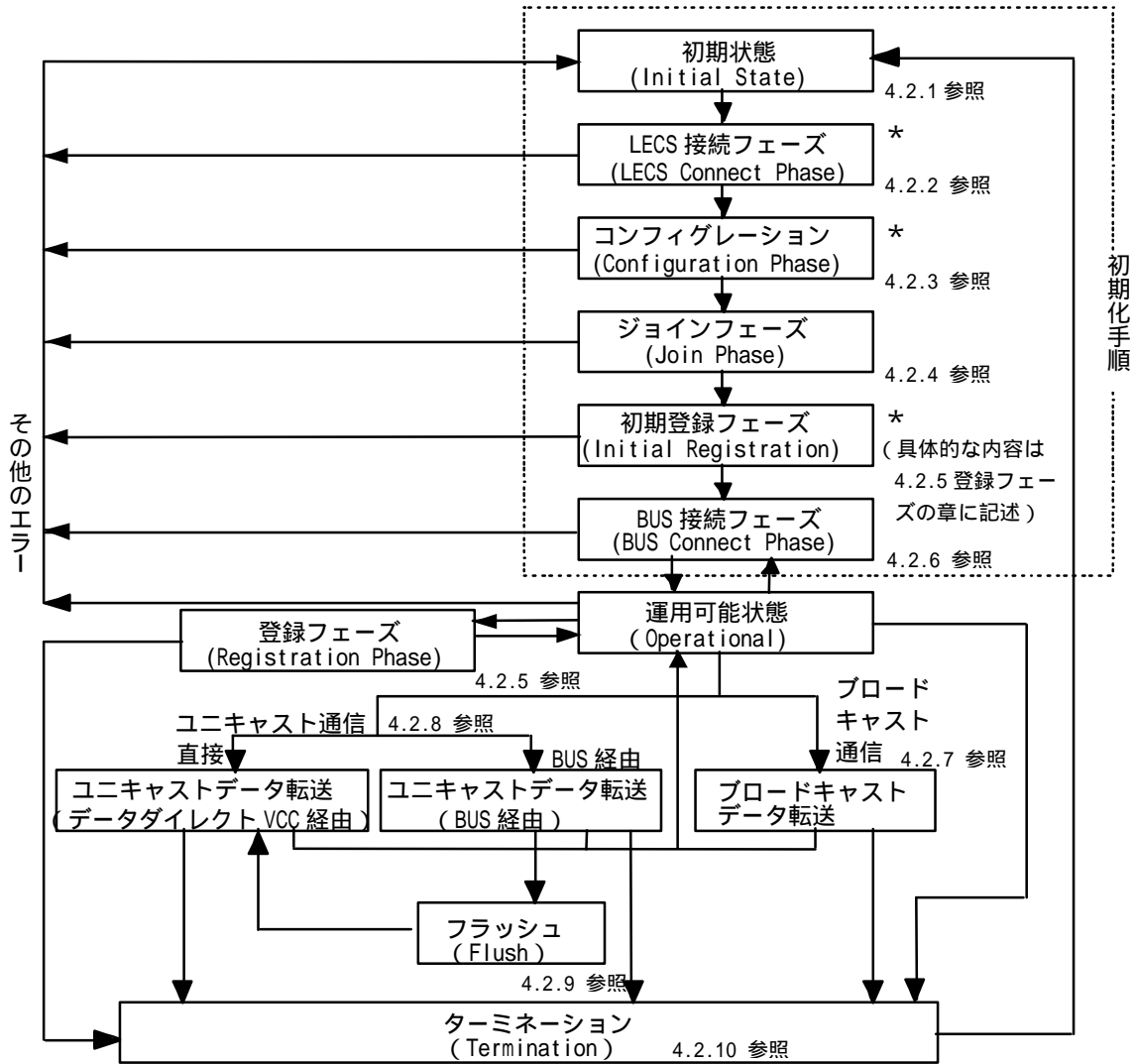

\* 省略可能

図 4-1 / JF-AF0084.00 補遺 各フェーズの一般的な流れの例

まず、エミュレーテッド LAN に加わったクライアントは、初期化手順において基本的なパラメータ設定やサーバとの接続、クライアントのアドレス情報などの登録を行い、運用可能状態に遷移する。この際、LECS 接続フェーズ、コンフィグレーションフェーズ、初期登録フェーズは省略可能な場合もありうる。運用可能状態からはユニキャスト通信またはブロードキャスト通信が可能である。ユニキャスト通信では、通信相手と直接接続する準備が整っていない場合、最初 BUS 経由で通信が行われる。その場合には、準備が整った時点でフラッシュプロトコルにより順序制御を行い直接通信に遷移する。通信が終了すると運用可能状態に戻る。なお、LAN エミュレーションでの通信を終結する場合には関連する SVC や保持している情報の解放を行い、初期状態に戻る。フェーズの詳細は 4.2 節に示す。また、「初期登録フェーズ」と「登録フェーズ」は 4.2.5 節でまとめて説明している。

LAN エミュレーション バージョン 2.0 では、初期化手順中のコンフィグレーションフェーズ、ジョインフェーズ、初期登録フェーズにおいて、他のフェーズでは各所にて TLV 情報の登録手順などが追加されている。

## 4.2 各フェーズの動作

### 4.2.1 初期状態(Initial State)

#### 機能概要

初期状態は、LE クライアント (LEC) 及び LE サーバ (LES) それぞれが有するパラメータの初期設定を行う。

また、パラメータの範囲が定められているものはその範囲内で設定する。

#### 手順

初期値の設定方法は、ユーザマターである。

### 4.2.2 LECS 接続フェーズ(LECS Connect Phase)

#### 機能概要

LECS 接続フェーズは、次のコンフィグレーションフェーズで LEC が LECS から LES の ATM アドレス等を取得するために使用される LEC-LECS 間の接続(コンフィグレーションダイレクト VCC)確立手順である。

LEC は、LEC-LECS 間の接続(コンフィグレーションダイレクト VCC)を以下の順番で確立しようと試みる。

- (1)すでにコンフィグレーションされた LECS アドレスを使用する。
- (2)ILMI プロトコルで ATM アドレスを得た後、接続を確立しようとする。
- (3)既知の Well-known アドレスによって接続を確立しようとする。

#### 手順

LEC1 から SVC または PVC で接続を確立する。



図 4-2 / JF-AF0084.00 補遺 LECS 接続フェーズの例

### 4.2.3 コンフィグレーションフェーズ(Configuration Phase)

#### 機能概要

LECS 接続フェーズで確立されたコンフィグレーションダイレクト VCC を用いて、LES の ATM アドレスと、エミュレーテッド LAN 加入のために必要な制御パラメータを取得することを目的としている。

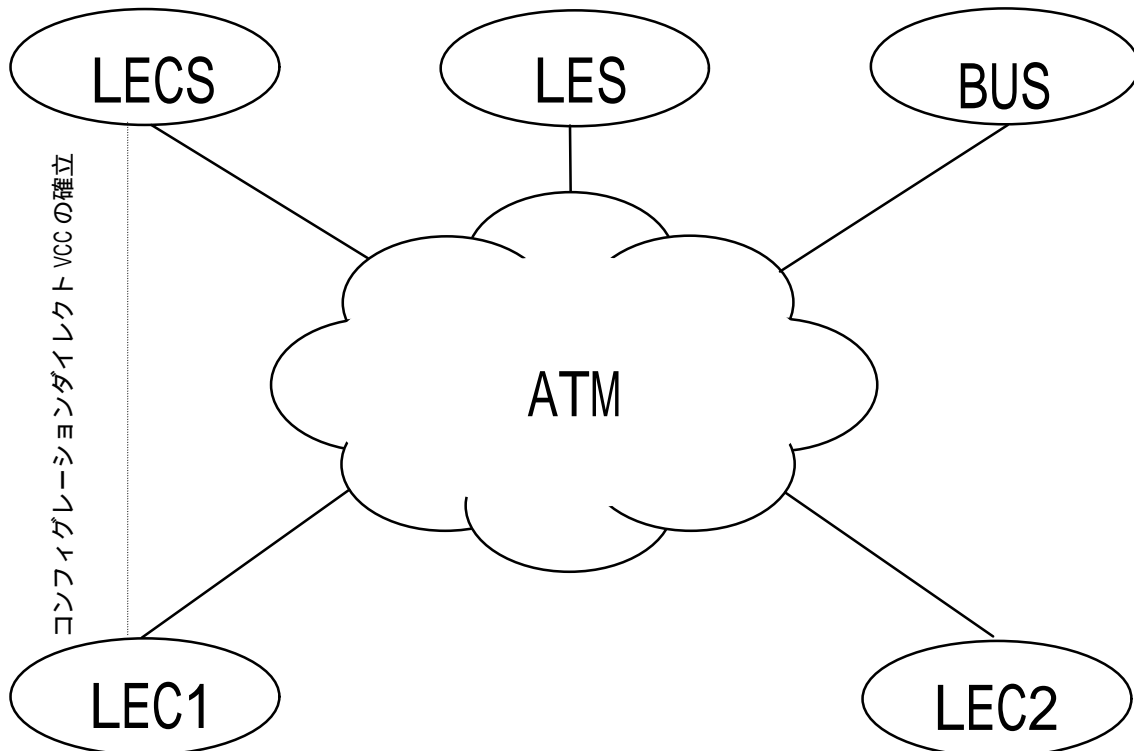
LECS の使用が LEC から要求されない場合は、LEC はこのフェーズを省略する可能性がある。

#### 手順



図 4-3 / JF-AF0084.00 補遺 コンフィグレーションフェーズの例

LEC1 から LE\_CONFIGURE\_REQUEST を LECS 宛に送信する。

LECS は、LE\_CONFIGURE\_REQUEST を受信すると LE\_CONFIGURE\_RESPONSE を LEC1 に返す。このフレームには LES の ATM アドレスの他、LAN タイプ、最大フレームサイズ、ELAN ネーム、TLV 等の制御パラメータが格納されている。

#### 4.2.4 ジョインフェーズ(Join Phase)

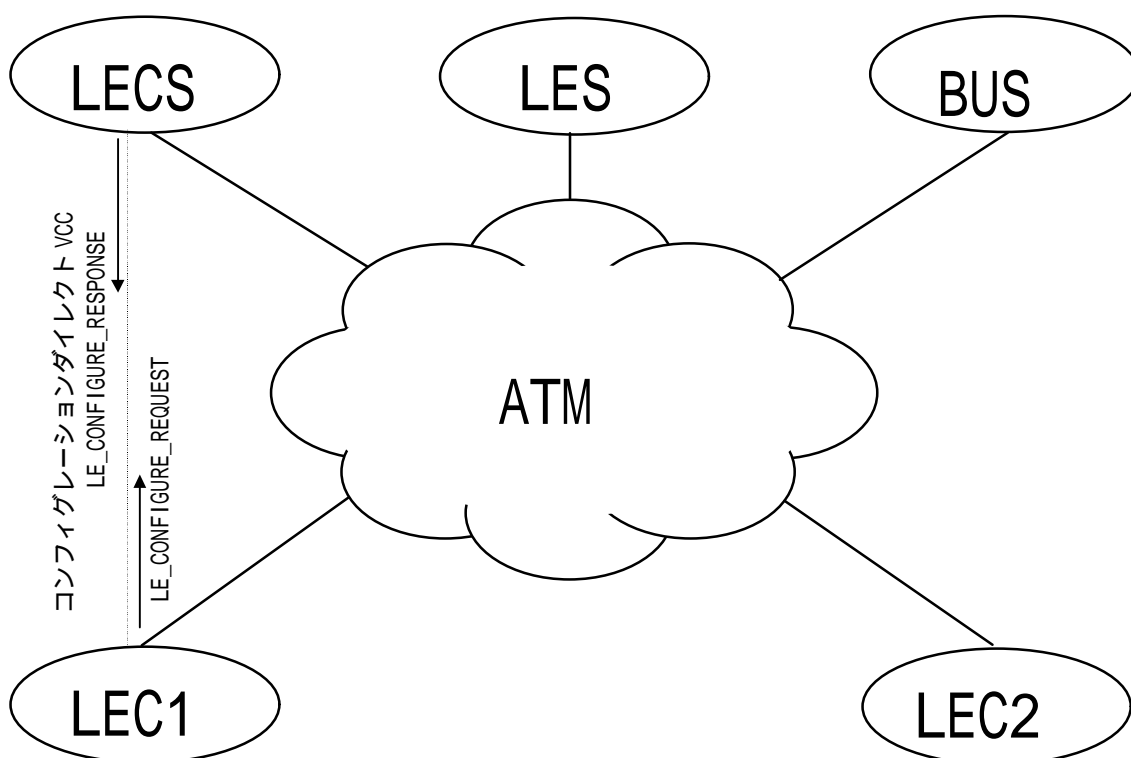
##### 機能概要

LEC は LES との間でコントロールダイレクト VCC を確立する。その後、LEC は LE\_JOIN\_REQUEST を送信し、LE\_JOIN\_RESPONSE を受信することで、エミュレーテッド LAN への加入手続きを完了する。これらの制御情報の送信用に LES はコントロールディストリビュート VCC (オプション) を使用してもよい。

LAN エミュレーション バージョン 2.0 では TLV 関連フィールドが拡張され LE\_JOIN\_REQUEST フレームで X5-Adjustment、Preferred-LES、レイヤ 3 アドレスが、LE\_JOIN\_RESPONSE フレームで ELAN-ID、ローカルセグメント ID がサポートされている。

##### 手順



図 4-4 / JF-AF0084.00 補遺 ジョインフェーズの例

LEC1 はコントロールダイレクト VCC を確立する。

LEC1 は LE\_JOIN\_REQUEST を送信する。

LES はコントロールディストリビュート VCC (オプション) を LEC1 との間に確立してもよい。

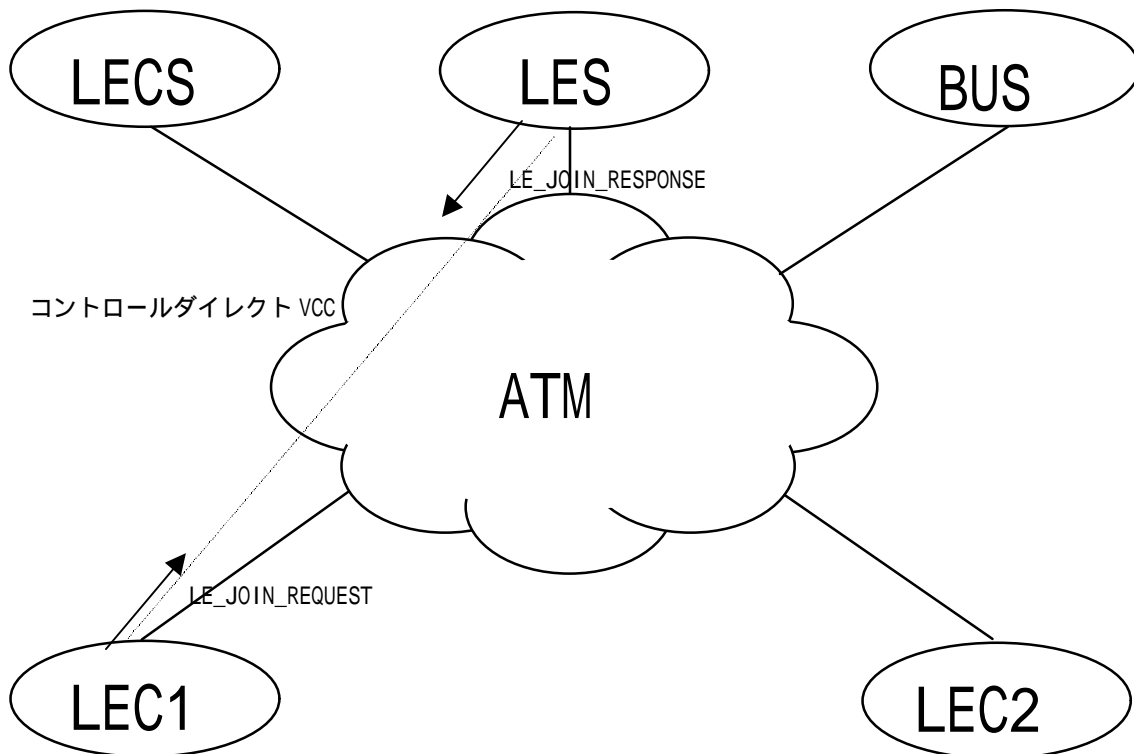
LES はコントロールダイレクト VCC かコントロールディストリビュート VCC (オプション) のどちらかを用いて LE\_JOIN\_RESPONSE で応答する。

LEC1 のエミュレーテッド LAN への加入手続きが完了する。



#### 4.2.5 登録フェーズ(Registration Phase)

##### 機能概要

登録とは、LEC と LES との間でユニキャスト/マルチキャスト MAC アドレス、非多重/LLC 多重 ATM アドレス、TLV 情報の登録作業及び登録抹消作業を行うことである。LES が LEC のアドレス情報をテーブルとして持つことにより、LES はアドレス解決要求に応えることが可能となる。

登録プロトコルは、初期登録フェーズ及び運用状態における登録フェーズにおいて用いられる。

LAN エミュレーション バージョン 2.0 において、LE\_REGISTER\_REQUEST フレームに TLV 関連フィールドが追加された。この LEC の TLV 情報は、MAC アドレス、ATM アドレスとともに LES に登録される。LE\_REGISTER\_REQUEST フレームでサポートされる TLV 情報は、LLC-Muxed-ATM-Address、Service-Category、User Defined TLVs である。

##### 手順



図 4-5 / JF-AF0084.00 補遺 登録の例

LEC1 はコントロールダイレクト VCC 上で、登録の場合はアドレス情報の登録のために LE\_REGISTER\_REQUEST を、登録抹消の場合は LE\_UNREGISTER\_REQUEST を LES に対して送信する。LES はコントロールダイレクト VCC もしくはコントロールディストリビュート VCC 上で、登録の場合は LE\_REGISTER\_RESPONSE を登録抹消の場合は LE\_UNREGISTER\_RESPONSE を LEC1 に送信し、登録/登録抹消の可否を通知する。

#### 4.2.6 BUS 接続フェーズ(BUS Connect Phase)

##### 機能概要

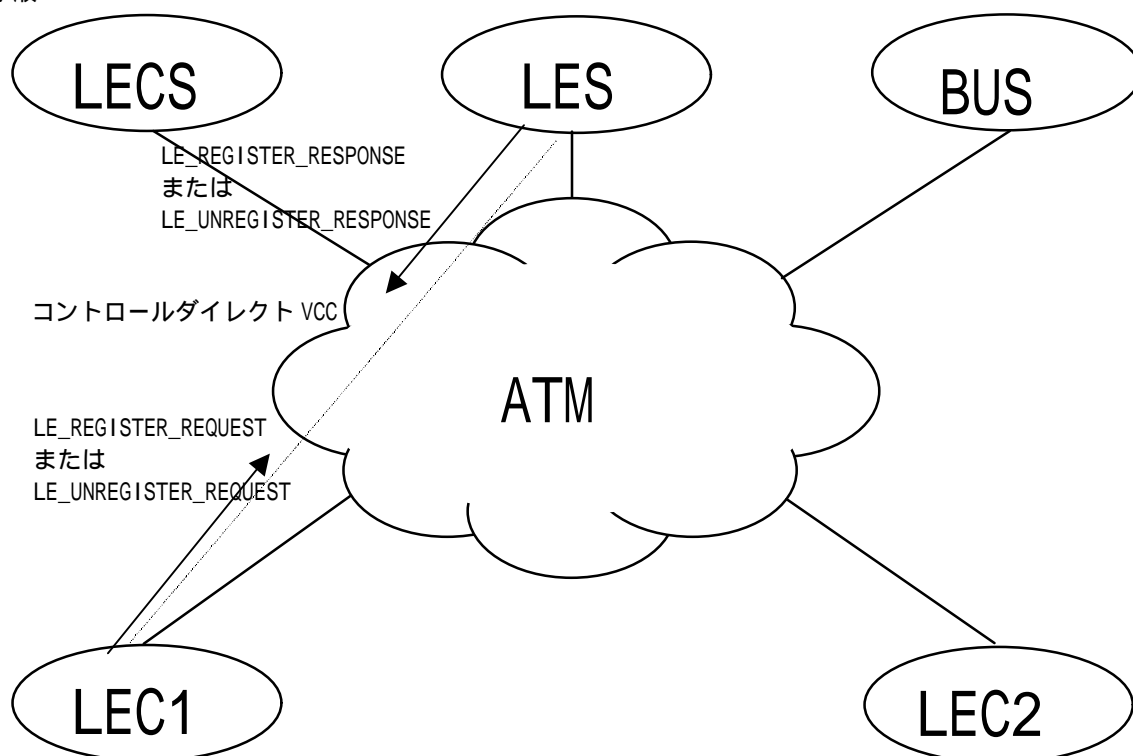
デフォルトマルチキャストセンド VCC に対してマルチキャストフォワード VCC を確立することにより、ブロードキャストを可能とする。

##### 手順



図 4-6 / JF-AF0084.00 補遺 BUS 接続フェーズの例

##### [ 前提 ]

LEC1 は事前にアドレス解決 (3.4.2 参照) によりブロードキャストアンノウンサーバ (BUS) の ATM アドレスの解決を行う。

LEC1 はデフォルトマルチキャストセンド VCC を BUS に対して確立する。

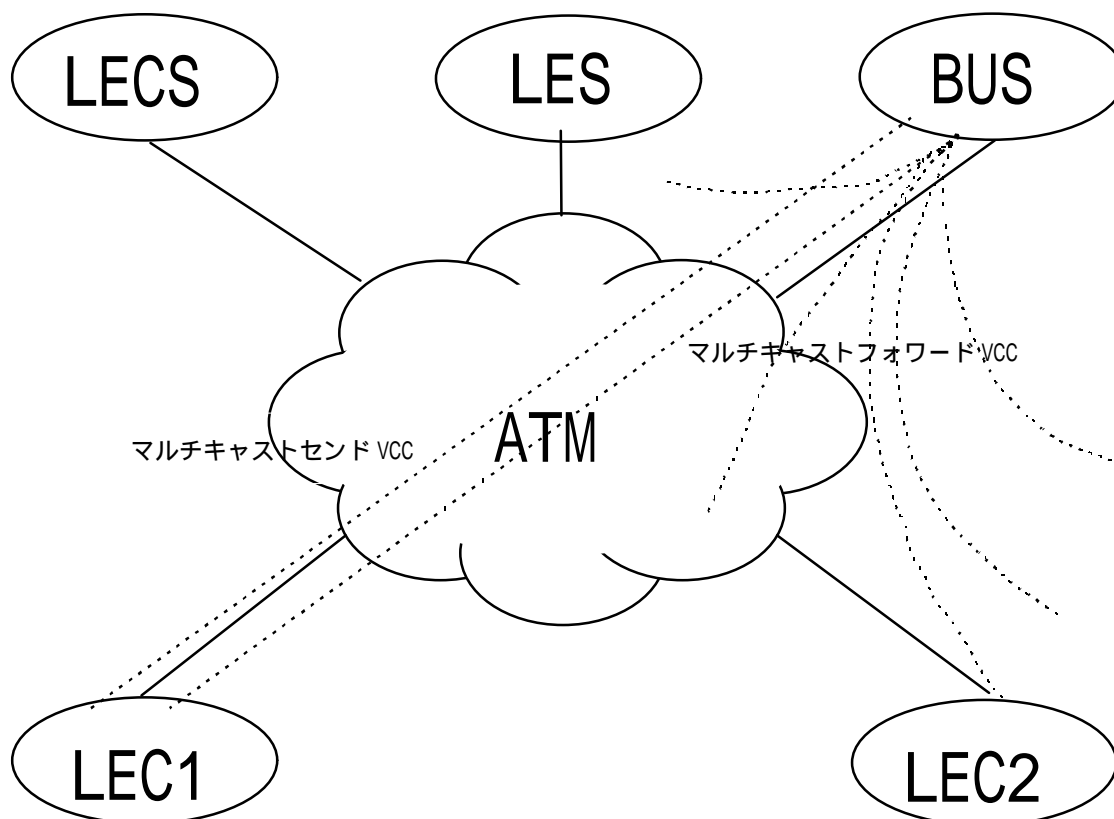
LEC1 はセレクトティブマルチキャストセンド VCC (オプション) を BUS に対して確立してもよい。

BUS は該当する LEC に対してマルチキャストフォワード VCC を確立する。これは該当 LEC を既設のポイント・マルチポイント VCC に追加することで実現される。

#### 4.2.7 ブロードキャストデータ転送

##### 機能概要

BUS 機能によるブロードキャスト及びマルチキャストフレームの転送を行う。

##### 手順



図 4-7 / JF-AF0084.00 補遺 マルチキャストデータ転送の例

##### [ 前提 ]

BUS 接続によるマルチキャストセンド VCC 及びマルチキャストフォワード VCC の確立を行う。

LEC1 から BUS へマルチキャストフレーム送信を行う (デフォルトマルチキャストセンド VCC、セレクトティブマルチキャストセンド VCC)。

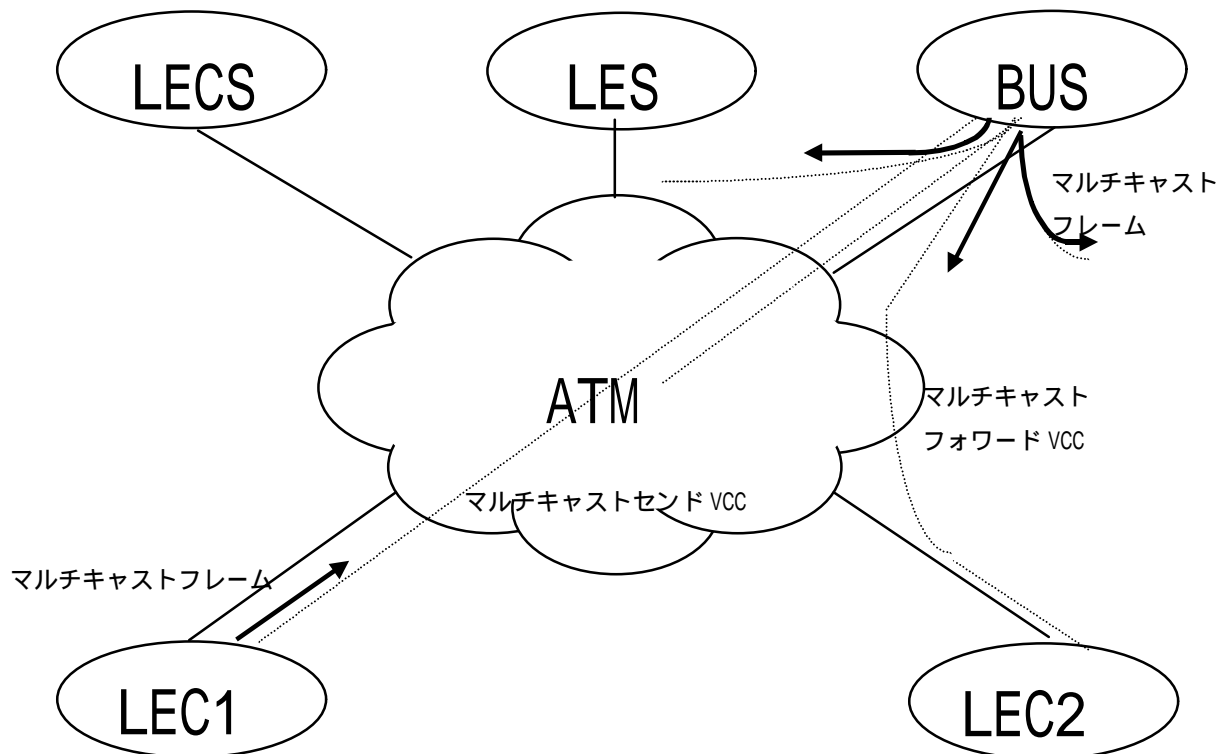
また BUS に対するブロードキャストデータ送信、マルチキャストデータ送信に使用される VCC は、デフォルトマルチキャストセンド VCC を用い、オプションとしてある特定のマルチキャストデータ送信に使用される VCC は、セレクトティブマルチキャストセンド VCC を用いる。

このマルチキャストセンド VCC は非多重とする。

ブロードキャストデータフレームの転送

BUS は、ジョイン要求により、V2 ケーパブルあるいはセレクトティブマルチキャストにより確立された LEC に対し、ブロードキャストデータフレームを転送する (マルチキャストフォワード VCC)。

マルチキャストデータフレームの転送

BUS は、マルチキャストのあて先を受信するように登録されている LEC、セレクトティブマルチキャストにより確立された LEC に対して誤りなく転送し、その他の LEC には 1 回以上転送する (マルチキャストセンド VCC またはマルチキャストフォワード VCC)。

#### 4.2.8 ユニキャストデータ転送

##### 機能概要

LEC間のユニキャストフレームの転送を行う。

その転送には、2つの経路(データダイレクトVCC経由あるいはBUS経由)がある。データダイレクトVCC経由のフレーム転送は、データダイレクトVCCの確立が必要である。LECがデータダイレクトVCCを知らない場合、あるいはデータダイレクトVCCが未確立の場合は、BUS経由でマルチキャストセンドVCCもしくはマルチキャストフォワードVCCを組み合わせ転送される。

##### 手順



図 4-8 / JF-AF0084.00 補遺 ユニキャストデータ転送 (BUS 経由) の例

##### [前提]

###### ・BUS 経由の場合

LEC1 は BUS へデータフレームを送信する (マルチキャストセンド VCC)。

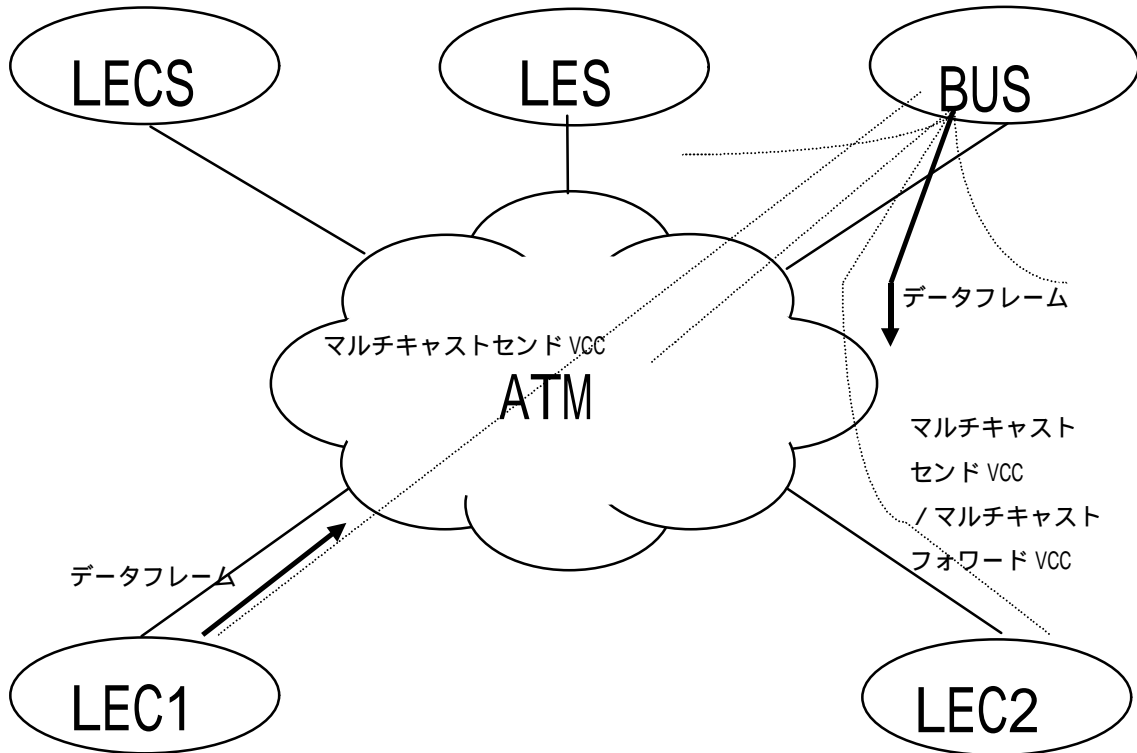
このマルチキャストセンド VCC は非多重でなければならない。

BUS から LEC2 へデータフレームを転送する (マルチキャストフォワード VCC またはマルチキャストセンド VCC)。



図 4-9 / JF-AF0084.00 補遺 ユニキャストデータ転送 ( Direct ) の例

[ 前提 ]

- ・データダイレクト VCC 経由の場合

データダイレクト VCC は、非多重または LLC 多重のどちらでもよい。

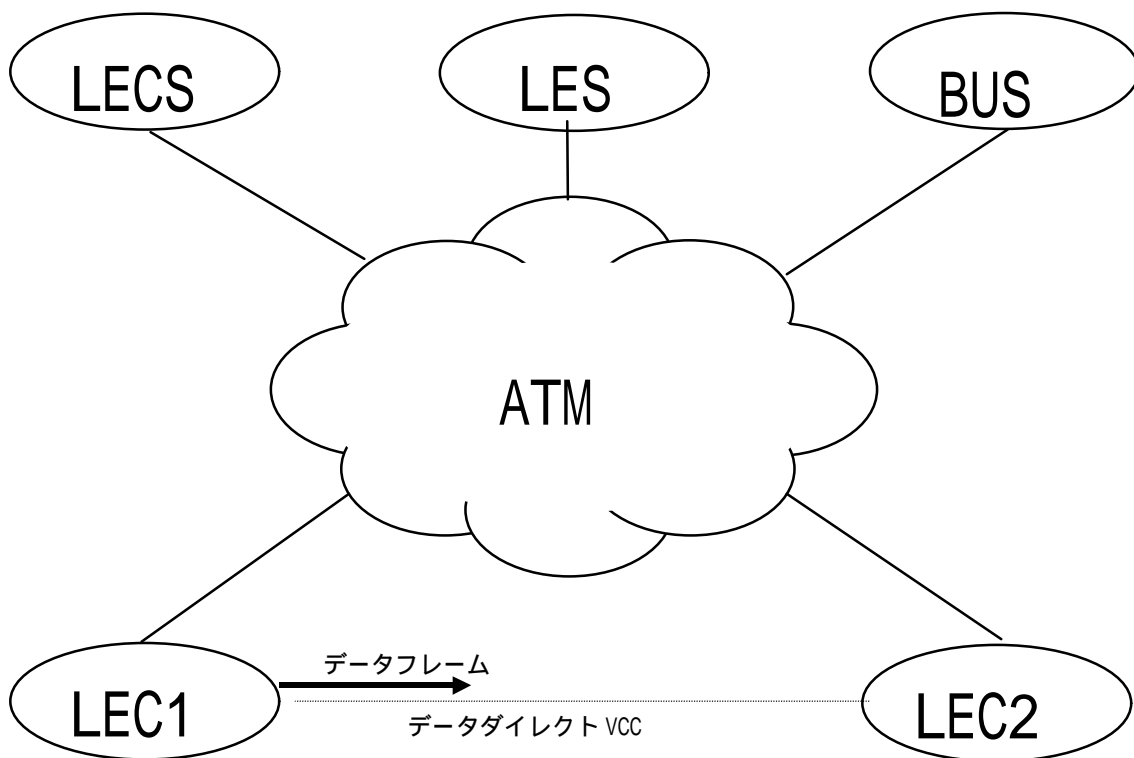
データダイレクト VCC 用の他の LE クライアントの ATM アドレスを得るため LE\_ARP\_REQUEST、LE\_ARP\_RESPONSE の SOURCE-ATM-ADDRESS フィールドや、TARGET-ATM-ADDRESS フィールドを使う場合は、非多重のデータダイレクト VCC を用いる。

同じ目的で LE\_ARP\_REQUEST、LE\_ARP\_RESPONSE の LLC-Mixed-ATM-Address TLV を使う場合は、LLC 多重のデータダイレクト VCC を用いる。

#### 4.2.9 フラッシュ(Flush)

##### 機能概要

フラッシュメッセージプロトコルは、LEC 間の経路を切り換える際に古い経路上のデータフレームの転送を終了してから新しい経路上でのデータフレームの転送を開始するための手段を提供し、これによってユニキャストフレームの順序が保証される。LEC が経路切り換え期間中に古い経路上にデータフレームを送信しないのであれば、フラッシュプロトコルを使用しなくてもよい。

マルチキャストフレームの順序を保証するためには、LEC は経路切り換え期間中に古い経路上にデータフレームを送信しないようにする。

BUS が、与えられた LAN に対して先に対するデータフレームをフォワードするための経路を、マルチキャストセンド VCC とマルチキャストフォワード VCC との間で切り換える際にも、フラッシュメッセージプロトコルを適用してフレームの順序を保証する。

フラッシュ要求は、LLC 多重データダイレクト VCC 上で転送される場合にのみ、LLC 多重化コントロールフレームフォーマットを使用する。LLC 多重化ヘッダには ELAN-ID が設定される。フラッシュ応答はコントロール VCC 上で転送されるので、必ず非多重化コントロールフレームフォーマットを使用する。

##### 手順

以下に例として、LEC1 から LEC2 への経路を BUS 経由からデータダイレクト VCC に変更する場合の手順を示す。前提として、LEC1 から LEC2 へのデータフレームが BUS 経由で転送されている。



図 4-10 / JF-AF0084.00 補遺 フラッシュ要求の転送の例

LEC1 から LEC2 へのフラッシュ要求を、BUS 経由で転送する。フラッシュメッセージは、LAN エミュレーションのデータフレームヘッダの LECID の位置にマーカとしてコントロールフレームを指定することによって、データフレームと区別できる。この図の場合のフラッシュ要求には、非多重化コントロールフレームフォーマットを使用する。LEC1 はフラッシュ応答を受信するか、応答待ちタイマが満了するまで、古い経路上にデータフレームを送信してはならない。LEC1 はタイムアウト後フラッシュ要求の再送が可能である。

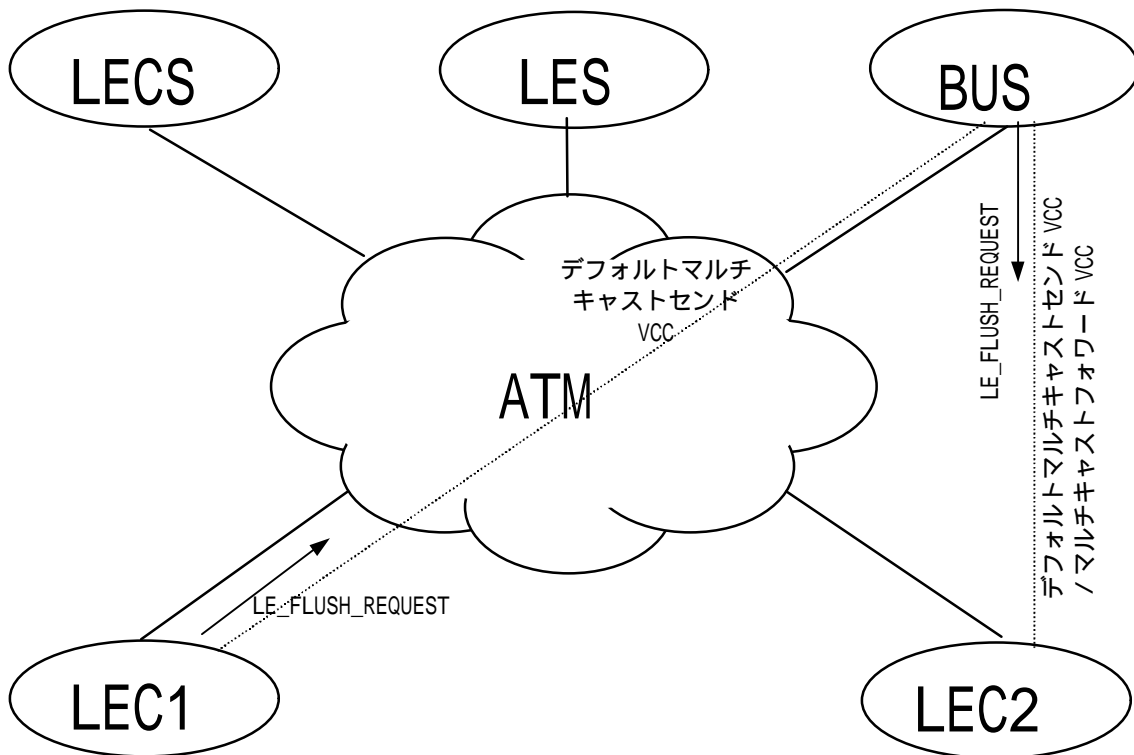

図 4-11 / JF-AF0084.00 補遺 フラッシュ応答の転送の例

LEC2 から LEC1 へのフラッシュ応答を、LES 経由で転送する。LEC1 はフラッシュ応答を受信した後、経路を BUS 経由からデータダイレクト VCC に切り換える。経路の切り換え後のデータフレームは、データダイレクト VCC 上で転送される。

#### 4.2.10 ターミネーション(Termination)

##### 機能概要

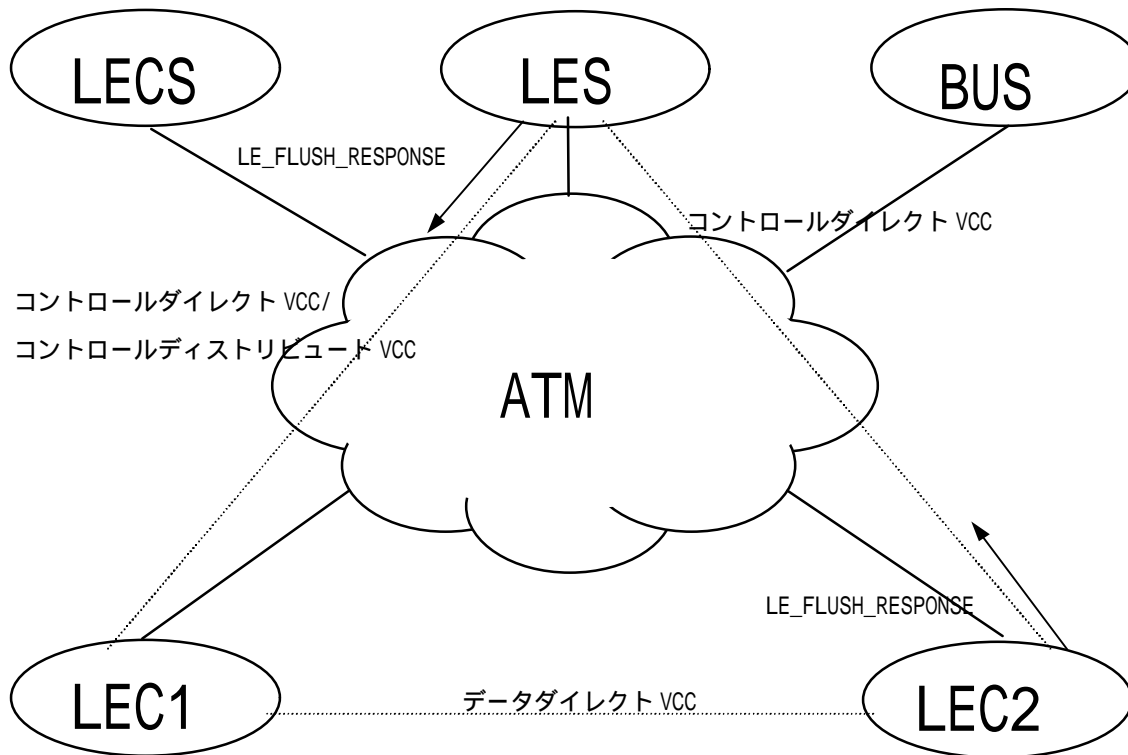
ターミネーションは LEC がエミュレーテッド LAN から離脱する際に使用されるプロトコルである。

ただし、プロトコルといってもサーバ/クライアント間でメッセージの交換があるわけではなく、コネクションを解放することでターミネーションは完了する。

##### 手順

[LEC からのターミネーション]



図 4-12 / JF-AF0084.00 補遺 LEC からのターミネーションの例

すべての非多重コネクション(すべてのコントロール VCC、すべての非多重データダイレクト VCC 及び BUS との間のすべてのデータ VCC)を解放する。

LLC 多重データダイレクト VCC が、別の LEC で使用されているときには、その VCC は解放せずに、使用を停止することでターミネーションを終了する。最後の LEC がその VCC を解放する。

ダイナミックに学習したすべての LE\_ARP キャッシュのエントリを削除する。

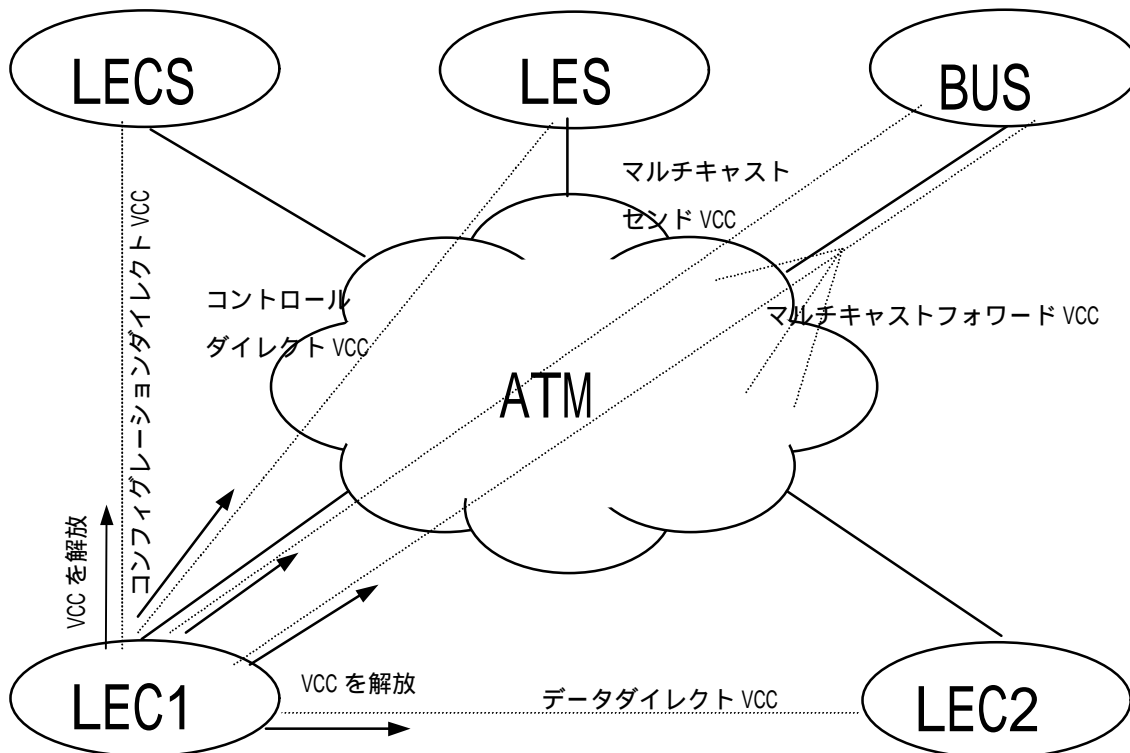

[LES からのターミネーション]



図 4-13 / JF-AF0084.00 補遺 LES からのターミネーションの例

当該 LEC に関するすべてのコネクションを解放する。

当該 LEC に関して登録されたすべての LAN あて先及びキャッシュされているアドレスを削除する。

## 5. LAN エミュレーションフレームフォーマット

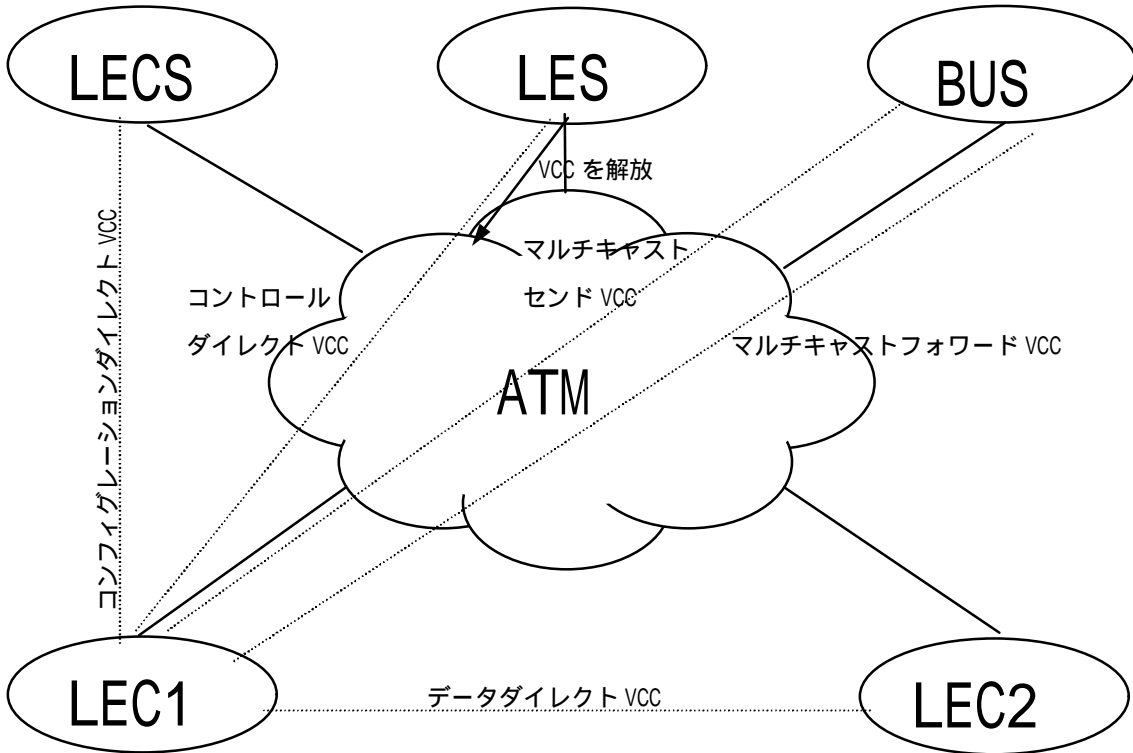
### 5.1 オクテット及びビット順序

以下では、LAN エミュレーションフレームフォーマットのフィールドは左から右へ記述されており、左が最上位オクテット、右が最下位オクテットとなる。またデータの送出順序は、各行の左端のオクテットから右方向に、上端の行から下方向に送出される。図 5-1 / JF-AF0084.00 補遺にデータ送出順序を示す。

0	1	2	3
0 1 2 3 4 5 6 7 8 9	0 1 2 3 4 5 6 7 8 9	0 1 2 3 4 5 6 7 8 9	0 1 2 3 4 5 6 7 8 9 0 1
0	1	2	3
4	5	6	7
8	9	10	11

図 5-1 / JF-AF0084.00 補遺 データ送出順序

オクテットはダイアグラムの左端のビットが最上位ビットである。例えば次のダイアグラムは 10 進数で 170 であり、ラベル 0 が最上位ビットとなる。

0	1	2	3	4	5	6	7
1	0	1	0	1	0	1	0

図 5-2 / JF-AF0084.00 補遺 ビット意味

同時に複数オクテットのフィールドを示す場合も、フィールド全体の最も左が最上位オクテットとなる。複数オクテットフィールドの転送は、最上位オクテットから行われる。

また、16 進数表記は、“X”で表す。例えば、X“0101”は 10 進数で 257 である。

## 5.2 LEデータフレーム

LAN エミュレーションのデータフレームには、2つのフォーマットが用いられる。1つは ISO 8802-3/CSMA-CD (IEEE 802.3) 対応のフォーマット(図 5-3 / JF-AF0084.00 補遺及び、図 5-4 / JF-AF0084.00 補遺)、2つ目は ISO 8802-5 (IEEE 802.5 またはトークンリング) 対応のフォーマット(図 5-5 / JF-AF0084.00 補遺及び、図 5-6 / JF-AF0084.00 補遺)である。

オフセット

0	LE ヘッダ	あて先 MAC アドレス
4	あて先 MAC アドレス	
8	送信元 MAC アドレス	
12	送信元 MAC アドレス	タイプ/データ長
16	データ	

- ・ LE ヘッダ (2 オクテット) : ジョインフェーズにおいて与えられる送信元 LEC の LECID または X"0000"
- ・ 最小フレーム長 : 62 オクテット
- ・ FCS 無し

図 5-3 / JF-AF0084.00 補遺 LAN エミュレーションデータフレームフォーマット  
(IEEE802.3/イーサネット - 非多重)

オフセット

0	LLC	OUI
4	OUI	フレームタイプ
8	ELAN-ID	
12	LE ヘッダ	あて先 MAC アドレス
16	あて先 MAC アドレス	
18	送信元 MAC アドレス	
24	送信元 MAC アドレス	タイプ/データ長
28	データ	

- ・ LLC : X"AAAA03" 次に OUI がくることを示す。
- ・ OUI : X"00A03E" The ATM Forum を示す。
- ・ フレームタイプ : X"000C" IEEE802.3/イーサネットデータフレームであることを示す。
- ・ ELAN-ID : X"00000000"以外
- ・ LE ヘッダ (2 オクテット) : ジョインフェーズにおいて与えられる送信元 LEC の LECID または X"0000"
- ・ 最小フレーム長 : 74 オクテット
- ・ FCS 無し

図 5-4 / JF-AF0084.00 補遺 LAN エミュレーションデータフレームフォーマット  
(IEEE802.3/イーサネット - LLC 多重化)

オフセット

0	LE ヘッダ	AC パッド	FC
4	あて先 MAC アドレス		
8	あて先 MAC アドレス	送信元 MAC アドレス	
12	送信元 MAC アドレス		
16 ~ 46	ルーティング情報		
	データ		

- ・ LE ヘッダ(2 オクテット): ジョインフェーズにおいて与えられる送信元 LEC の LECID または X"0000"
- ・ 最小フレーム長: 16 オクテット
- ・ FCS 無し
- ・ AC パッドオクテットは未使用(送信時は任意にコーディングされ、受信時は無視される)
- ・ FC オクテット: '01000YYY' (YYY は優先度)

図 5-5 / JF-AF0084.00 補遺 LAN エミュレーションデータフレームフォーマット  
(IEEE802.5 - 非多重)

オフセット

0	LLC		OUI
4	OUI	フレームタイプ	
8	ELAN-ID		
12	LE ヘッダ	AC パッド	FC
16	あて先 MAC アドレス		
20	あて先 MAC アドレス	送信元 MAC アドレス	
24	送信元 MAC アドレス		
28 ~ 58	ルーティング情報		
	データ		

- ・ LLC: X"AAAA03" 次に OUI がくることを示す。
- ・ OUI: X"00A03E" The ATM Forum を示す。
- ・ フレームタイプ: X"000D" IEEE802.5 データフレームであることを示す。
- ・ ELAN-ID: X"00000000"以外
- ・ LE ヘッダ(2 オクテット): ジョインフェーズにおいて与えられる送信元 LEC の LECID または X"0000"
- ・ 最小フレーム長: 16 オクテット
- ・ FCS 無し
- ・ AC パッドオクテットは未使用(送信時は任意にコーディングされ、受信時は無視される)
- ・ FC オクテット: '01000YYY' (YYY は優先度)

図 5-6 / JF-AF0084.00 補遺 LAN エミュレーションデータフレームフォーマット  
(IEEE802.5 - LLC 多重化)

### 5.3 LE コントロールフレーム

LLC 多重データダイレクト VCC で送られる LE\_FLUSH\_REQUEST、及び READY\_IND、READY\_QUERY を除く全ての LAN エミュレーションコントロールフレームは、図 5-7 / JF-AF0084.00 補遺に記述されるフォーマットを用いる。

オフセット				
0	マーカ		プロトコル	バージョン
4	OP-CODE		状態表示	
8	トランザクション ID			
12	要求者 LECID		フラグ	
16	送信元 LAN あて先			
24	ターゲット LAN あて先			
32	送信元 ATM アドレス			
52	LAN タイプ	最大フレームサイズ	TLV 数	ELAN ネームサイズ
56	ターゲット ATM アドレス			
76	ELAN ネーム			
108	TLV の開始			

- ・マーカ : X"FF00"
- ・プロトコル : X"01"
- ・バージョン : X"01"

図 5-7 / JF-AF0084.00 補遺 LAN エミュレーションコントロールフレームフォーマット

LLC 多重データダイレクト VCC で送られる LE\_FLUSH\_REQUEST のフォーマットを図 5-8 / JF-AF0084.00 補遺に示す ( READY\_IND、READY\_QUERY のフォーマットについては標準本文の Annex B 参照 )。

オフセット

0	LLC		OUI
4	OUI	フレームタイプ	
8	ELAN-ID		
12	マーカ	プロトコル	バージョン
16	OP-CODE	状態表示	
20	トランザクション ID		
24	要求者 LECID	フラグ	
28	送信元 LAN あて先		
36	ターゲット LAN あて先		
44	送信元 ATM アドレス		
64	LAN タイプ	最大フレームサイズ	TLV 数 ELAN ネーム サイズ
68	ターゲット ATM アドレス		
88	ELAN ネーム		
120	TLV の開始		

- ・ LLC : X"AAAA03" 次に OUI がくことを示す。
- ・ OUI : X"00A03E" The ATM Forum を示す。
- ・ マーカ : X"FF00"
- ・ プロトコル : X"01"
- ・ バージョン : X"01"

図 5-8 / JF-AF0084.00 補遺 LAN エミュレーションコントロールフレームフォーマット

全てのコントロールフレームフォーマットに共通のフィールドの意味を表 5-1 / JF-AF0084.00 補遺に示す。

表 5-1 / JF-AF0084.00 補遺 コントロールフレームヘッダ情報

オフセット	サイズ	名称	機能
0	2	マーカ	コントロールフレーム = X“FF00”
2	1	プロコトル	ATM LAN エミュレーションプロコトル = X“01”
3	1	バージョン	ATM LAN エミュレーションプロコトルバージョン = X“01”
4	2	OP-CODE	コントロールフレームタイプ
6	2	状態表示	要求時は常に X“0000”
8	4	トランザク ション ID	受信側で応答を区別するための値であり、要求者により与えられ応答者より返される
1 2	2	要 求 者 LECID	要求を行う LEC の LECID ( 未知の場合 X“0000” )
1 4	2	フラグ	ビットフラグ
1 6	9 2		OP-CODE によって決定する残フィールド

表 5-2 / JF-AF0084.00 補遺に、各メッセージに対応した表 5-1 / JF-AF0084.00 補遺の「OP-CODE によって決定する残フィールド」内の各フィールドの内容を示す。

表 5-2 / JF-AF0084.00 補遺(1/2) 各メッセージにおけるコントロールフレームヘッダ情報

メッセージ名称	送信元 LAN あて先	ターゲット LAN あて先	送信元 ATM アドレス	LAN タイプ
LE_CONFIGURE_REQUEST_RESPONSE	LEC となる MAC アドレス、またはルータ識別子 “not present” でエンコードされる場合もある	送信時：X“00” 受信時：無視する	情報が要求された LEC の ATM アドレス	X“00”：未定義 X“01”：イーサネット / IEEE802.3 X“02”：IEEE802.5
LE_JOIN_REQUEST_RESPONSE	オプションのユニキャスト LAN あて先 SOURCE-ATM-ADDRESS のペアとして登録される	送信時：X“00” 受信時：無視する	要求を発信する LEC の ATM アドレス	X“00”：未定義 X“01”：イーサネット / IEEE802.3 X“02”：IEEE802.5
LE_REGISTER_REQUEST_RESPONSE	登録を試みている MAC アドレス、または LEC のルータ記述子	送信時：X“00” 受信時：無視する	要求を発信する LEC の非多重 ATM アドレス	送信時：X“00” 受信時：無視する
LE_UNREGISTER_REQUEST_RESPONSE	登録を試みている MAC アドレス、または LEC のルータ記述子	送信時：X“00” 受信時：無視する	要求を発信する LEC の非多重 ATM アドレス	送信時：X“00” 受信時：無視する
LE_ARP_REQUEST_RESPONSE	LE_ARP シーケンスでトリガがかかるデータフレームからの送信元 MAC アドレス。本 TAG は “not present” としてエンコードされる場合もある	解決を要求されている ATM アドレスに対応付けられる先ユニキャスト MAC アドレス、またはネクストルータ記述子。ターゲットの存在しない LE_ARP_REQUEST では、本フィールドの TAG は “not present”	要求者の非多重 ATM アドレス、または X“00” (存在しない場合)	送信時：X“00” 受信時：無視する
LE_FLUSH_REQUEST_RESPONSE	送信時：X“00” 受信時：無視する	フラッシュを要求されている先ユニキャスト MAC アドレス、またはネクストルータ記述子 LE_FLUSH_RESPONSE では本フィールドは不要 ターゲット VCC 上での LE_FLUSH_REQUEST では、本フィールドは X“00” でもよい	要求発信者の ATM アドレス	送信時：X“00” 受信時：無視する
LE_NARP_REQUEST	未使用 (X“00”)	既に無効であるターゲット ATM アドレスに対応付けられる先ユニキャスト MAC アドレスまたはネクストルータ記述子	要求者の非多重 ATM アドレス (要求元がない場合)	送信時：X“00” 受信時：無視する
LE_TOPOLOGY_REQUEST	送信時：X“00” 受信時：無視する	送信時：X“00” 受信時：無視する	送信時：X“00” 受信時：無視する	送信時：X“00” 受信時：無視する
LE_VERIFY_REQUEST_RESPONSE	送信時：X“00” 受信時：無視する	送信時：X“00” 受信時：無視する	送信時：X“00” 受信時：無視する	送信時：X“00” 受信時：無視する



表 5-2 / JF-AF0084.00 補遺(2/2) 各メッセージにおけるコントロールフレームヘッダ情報

メッセージ名称	最大フレームサイズ	TLV 数	ELAN ネームサイズ	ターゲット ATM アドレス	ELAN ネーム
LE_CONFIGURE_REQUEST_RESPONSE	X"00" ~ X"04" (*1)	TLV の要素の数	ELAN ネームのオクテット数	X"00" STATUS="Success"の場合 LES の ATM アドレス それ以外は X"00"	エミュレーションモード LAN の名前 (SNMP v2 表記)
LE_JOIN_REQUEST_RESPONSE	X"00" ~ X"05" (*1)	TLV の要素の数	ELAN ネームのオクテット数	送信時: X"00" 受信時: 無視する	エミュレーションモード LAN の名前 (SNMP v2 表記)
LE_REGISTER_REQUEST_RESPONSE	送信時: X"00" 受信時: 無視する	TLV の要素の数	送信時: X"00" 受信時: 無視する	送信時: X"00" 受信時: 無視する	送信時: X"00" 受信時: 無視する
LE_UNREGISTER_REQUEST_RESPONSE	送信時: X"00" 受信時: 無視する	TLV の要素の数	送信時: X"00" 受信時: 無視する	送信時: X"00" 受信時: 無視する	送信時: X"00" 受信時: 無視する
LE_ARP_REQUEST_RESPONSE	送信時: X"00" 受信時: 無視する	TLV の要素の数	送信時: X"00" 受信時: 無視する	X"00" ターゲット LAN へ先に対応する LEC の非多重 ATM アドレス	送信時: X"00" 受信時: 無視する
LE_FLUSH_REQUEST_RESPONSE	送信時: X"00" 受信時: 無視する	送信時: X"00" 受信時: 無視する	送信時: X"00" 受信時: 無視する	フラッシュ要求先 LEC の LLC 多重または非多重 ATM アドレス	送信時: X"00" 受信時: 無視する
LE_NARP_REQUEST	送信時: X"00" 受信時: 無視する	TLV の要素の数	送信時: X"00" 受信時: 無視する	ターゲット LAN へ先に対応していた LEC の非多重 ATM アドレス	送信時: X"00" 受信時: 無視する
LE_TOPOLOGY_REQUEST	送信時: X"00" 受信時: 無視する	送信時: X"00" 受信時: 無視する	送信時: X"00" 受信時: 無視する	LES にチェックを要求する ATM アドレス	送信時: X"00" 受信時: 無視する
LE_VERIFY_REQUEST_RESPONSE	送信時: X"00" 受信時: 無視する	TLV の要素の数	送信時: X"00" 受信時: 無視する	LES によってチェックされた ATM アドレス	送信時: X"00" 受信時: 無視する

(\*1) 値は最大 SDU(Service Data Unit)サイズを表す。具体的な値とサイズの関係については、標準本文 Table22 (74 ページ) などを参照のこと。

第1版 執筆作成協力者 (敬称略) (1998年5月現在)

( JF-AF0084.00 補遺 制定 )

第三部門委員会

部門委員長 飯島 裕雄 日本電気(株)  
副部門委員長 吉田 慎一郎 日本電信電話(株)  
副部門委員長 森 淳 沖電気工業(株)

委員 田中 寛 国際電信電話(株)  
" 大貫 雅史 NTT 移動通信網(株)  
" 松本 靖 Iマ・ティ・ティ・データ通信(株)  
" 牟田 総男 岩崎通信機(株)  
" 勝川 保 住友電気工業(株)  
" 酒井 一郎 日本アイ・ビー・エム(株)  
" 青山 滋 三菱電機(株)  
" 井坂 章 (株)リコー

委員 蟻川 義男 東京電力(株)  
" 中村 寿博 日本情報通信コンサルティング(株)  
" 小川 研一 富士通(株)  
" 中山 文信 (株)東芝  
" 森田 隆士 (株)日立製作所  
" 久保 輝幸 日本電信電話(株)  
" 小林 信之 三菱電機(株)

第三部門委員会第二専門委員会

専門委員長 森田 隆士 (株)日立製作所  
副専門委員長 久保 輝幸 日本電信電話(株)  
副専門委員長 小林 信之 三菱電機(株)

委員 後藤 俊彦 東京通信ネットワーク(株)  
" 高橋 英範 日本電信電話(株)  
" 藤間 良樹 NTT 移動通信網(株)  
" 三宅 篤 大阪メディアポ - ト(株)  
" 石山 伸記 アンリツ(株)  
" 牟田 総男 岩崎通信機(株)  
" 千村 保文 沖電気工業(株)  
" 高橋 匠 キヤノン(株)  
" 川尻 康夫 国際電気(株)  
" 西田 正樹 シャープ(株)  
" 大間 稔 住友電気工業(株)  
" 関 豊 (株)東芝  
" 金田 佳久 日本アイ・ビー・エム(株)  
" 坂本 秀紀 日本電気(株)

委員 坂本 篤 日本ビクター(株)  
" 宮川 徳一 日本無線(株)  
" 木下 成顕 (株)日立製作所  
" 大西 洋也 (株)フジクラ  
" 小沢 祐治 富士ゼロックス(株)  
" 若狭 慎司 富士通(株)  
" 難波 美香子 古河電気工業(株)  
" 森 孝志 松下通信工業(株)  
" 佐藤 浩之 三菱電機(株)  
" 寺尾 雄一 (株)リコー  
" 山崎 哲哉 (株)アルファシステムズ  
" 岩倉 久純 東京電力(株)  
" 加藤 芳章 日本情報通信コンサルティング(株)

[JF-AF0084.00 補遺の制定 検討グループ]

リーダー 西田 正樹 シャープ(株)  
サブリーダー 大西 洋也 (株)フジクラ  
委員 後藤 俊彦 東京通信ネットワーク(株)  
" 高橋 英範 日本電信電話(株)  
" 角田 靖夫 岩崎通信機(株)  
" 谷頭 昭夫 沖電気工業(株)  
" 川尻 康夫 国際電気(株)  
" 大間 稔 住友電気工業(株)  
" 関 豊 (株)東芝  
" 坂本 秀紀 日本電気(株)

委員 宮川 徳一 日本無線(株)  
" 小沢 祐治 富士ゼロックス(株)  
" 松田 高男 富士通(株)  
" 難波 美香子 古河電気工業(株)  
" 森 孝志 松下通信工業(株)  
" 佐藤 浩之 三菱電機(株)  
" 寺尾 雄一 (株)リコー  
" 加藤 芳章 日本情報通信コンサルティング(株)

事務局 元吉 茂 (第三技術部)