

TS-3GA-36.440(Rel10)v10.3.0
Evolved Universal Terrestrial Radio
Access Network (E-UTRAN);
General aspects and principles for
interfaces supporting Multimedia
Broadcast Multicast Service (MBMS)
within E-UTRAN

2012年9月19日制定

一般社団法人
情報通信技術委員会

THE TELECOMMUNICATION TECHNOLOGY COMMITTEE

本書は、一般社団法人情報通信技術委員会が著作権を保有しています。
内容の一部又は全部を一般社団法人情報通信技術委員会の許諾を得ることなく複製、
転載、改変、転用及びネットワーク上での送信、配布を行うことを禁止します。

Evolved Universal Terrestrial Radio Access Network (E-UTRAN); General aspects and principles for interfaces supporting Multimedia Broadcast Multicast Service (MBMS) within E-UTRAN

<参考> [Remarks]

1. 英文記述の適用レベル [Application level of English description]

適用レベル [Application level] : E2

本標準の本文、付属資料および付録の文章および図に英文記述を含んでいる。

[English description is included in the text and figures of main body, annexes and appendices.]

2. 国際勧告等の関連 [Relationship with international recommendations and standards]

本標準は、3GPP で承認された Technical Specification 36.440 (Version 10.3.0) に準拠している。

[This standard is standardized based on the Technical Specification 36.440 (Version 10.3.0) approved by 3GPP.]

3. 上記国際勧告等に対する追加項目等 [Departures from international recommendations]

原標準に対する変更項目 [Changes to original standard]

原標準が参照する標準のうち、TTC 標準に置き換える項目。 [Standards referred to in the original standard, which are replaced by TTC standards.]

原標準が参照する標準のうち、それらに準拠した TTC 標準等が制定されている場合は自動的に最新版 TTC 標準等に置き換え参照するものとする。 [Standards referred to in the original standard should be replaced by derived TTC standards.]

4. 工業所有権 [IPR]

本標準に関わる「工業所有権等の実施の権利に係る確認書」の提出状況は、TTC ホームページによる。

[Status of “Confirmation of IPR Licensing Condition” submitted is provided in the TTC web site.]

5. 作成専門委員会 [Working Group]

3GPP 専門委員会 [3GPP Working Group]

3GPP TS 36.440 V10.3.0 (2012-06)

Technical Specification

**3rd Generation Partnership Project;
Technical Specification Group Radio Access Network;
Evolved Universal Terrestrial Radio Access Network
(E-UTRAN);
General aspects and principles for interfaces supporting
Multimedia Broadcast Multicast Service (MBMS) within
E-UTRAN
(Release 10)**



Keywords

LTE, MBMS, STAGE 3, ACCESS, INTERFACE,
NETWORK

3GPP

Postal address

3GPP support office address

650 Route des Lucioles - Sophia Antipolis
Valbonne - FRANCE
Tel.: +33 4 92 94 42 00 Fax: +33 4 93 65 47 16

Internet

<http://www.3gpp.org>

Copyright Notification

No part may be reproduced except as authorized by written permission.
The copyright and the foregoing restriction extend to reproduction in all media.

© 2012, 3GPP Organizational Partners (ARIB, ATIS, CCSA, ETSI, TTA, TTC).
All rights reserved.

UMTS™ is a Trade Mark of ETSI registered for the benefit of its members

3GPP™ is a Trade Mark of ETSI registered for the benefit of its Members and of the 3GPP Organizational Partners

LTE™ is a Trade Mark of ETSI currently being registered for the benefit of its Members and of the 3GPP Organizational Partners

GSM® and the GSM logo are registered and owned by the GSM Association

Contents

Foreword	4
1 Scope	5
2 References	5
3 Definitions, symbols and abbreviations	5
3.1 Definitions	5
3.2 Symbols	6
3.3 Abbreviations	6
4 General Architecture for EUTRAN MBMS	6
5 Functions of M1 interface for MBMS	7
5.1 General	7
5.2 Multicast group management function	7
5.3 Content synchronization function	7
6 Functions of M2 interface for MBMS	7
6.1 General	7
6.2 M2 interface setup and configuration update functions	7
6.3 MBMS Session management function	7
6.3.1 M2 service context management function	7
6.3.2 MBMS E-RAB management functions	8
6.3.3 M2 link management function	8
6.3.4 MBMS Service Suspension and Resumption function	8
6.4 MBMS Scheduling Information transfer function	8
6.5 MBMS signalling synchronization over M2	8
6.6 M2 interface reset and error processing function	8
6.6.1 Error indication	8
6.6.2 Reset	8
6.7 MBMS Counting Function	8
7 Functions of M3 interface for MBMS	9
7.1 General	9
7.2 MBMS Session management function	9
7.2.1 M3 service context management function	9
7.2.2 MBMS E-RAB management functions	9
7.3 M3 interface reset and error processing function	9
7.3.1 Error indication	9
7.3.2 Reset	9
8 Protocol structure for MBMS related interface in E-UTRAN	9
8.1 General	9
8.2 M1	10
8.3 M2	10
8.4 M3	10
9 Other MBMS E-UTRAN Interface Specifications	10
9.1 Layer 1 for interfaces supporting MBMS within E-UTRAN (3GPP TS 36.441)	10
9.2 Signalling Transport for interfaces supporting MBMS within E-UTRAN (3GPP TS 36.442)	10
9.3 E-UTRAN M2 Application Protocol (M2AP) (3GPP TS 36.443)	10
9.4 E-UTRAN M3 Application Protocol (M3AP) (3GPP TS 36.444)	10
9.5 E-UTRAN M1 Data Transport (3GPP TS 36.445)	10
9.6 E-UTRAN MBMS synchronisation protocol (3GPP TS 25.446)	10
Annex A (informative): Change history	11

Foreword

This Technical Specification has been produced by the 3rd Generation Partnership Project (3GPP).

The contents of the present document are subject to continuing work within the TSG and may change following formal TSG approval. Should the TSG modify the contents of the present document, it will be re-released by the TSG with an identifying change of release date and an increase in version number as follows:

Version x.y.z

where:

- x the first digit:
 - 1 presented to TSG for information;
 - 2 presented to TSG for approval;
 - 3 or greater indicates TSG approved document under change control.
- y the second digit is incremented for all changes of substance, i.e. technical enhancements, corrections, updates, etc.
- z the third digit is incremented when editorial only changes have been incorporated in the document.

1 Scope.

The present document describes the overall architecture of the interface for the provision of MBMS in the E-UTRAN. This includes also a description of the general aspects, assumptions and principles guiding the architecture and interface. The MBMS functions to be provided within that architecture are summarized. It provides an introduction to the TSG RAN TS 36.44x series of UMTS Technical Specifications that define the different interfaces introduced for MBMS provision in E-UTRAN.

2 References

The following documents contain provisions which, through reference in this text, constitute provisions of the present document.

- References are either specific (identified by date of publication, edition number, version number, etc.) or non-specific.
- For a specific reference, subsequent revisions do not apply.
- For a non-specific reference, the latest version applies. In the case of a reference to a 3GPP document (including a GSM document), a non-specific reference implicitly refers to the latest version of that document *in the same Release as the present document*.

- [1] 3GPP TR 21.905: "Vocabulary for 3GPP Specifications".
- [2] 3GPP TS 36.441: "Layer 1 for interfaces supporting MBMS within E-UTRAN"
- [3] 3GPP TS 36.442: "Signalling Transport for interfaces supporting MBMS within E-UTRAN"
- [4] 3GPP TS 36.443: "EUTRAN M2 Application Protocol (M2AP)"
- [5] 3GPP TS 36.444: "EUTRAN M3 Application Protocol (M3AP)"
- [6] 3GPP TS 36.445: "E-UTRAN M1 Data Transport"
- [7] 3GPP TS 25.446: "MBMS synchronisation protocol (SYNC)"
- [8] 3GPP TS 23.246: "MBMS Architecture and functional description"
- [9] 3GPP TS 36.300: "E-UTRA and E-UTRAN overall description"
- [10] IETF RFC 4960 (2007-09): "Stream Control Transmission Protocol".

3 Definitions, symbols and abbreviations

3.1 Definitions

For the purposes of the present document, the terms and definitions given in TR 21.905 [1] and the following apply. A term defined in the present document takes precedence over the definition of the same term, if any, in TR 21.905 [1].

Definition format

<defined term>: *<definition>*.

example: text used to clarify abstract rules by applying them literally.

3.2 Symbols

For the purposes of the present document, the following symbols apply:

Symbol format

<symbol> <Explanation>

3.3 Abbreviations

For the purposes of the present document, the abbreviations given in TR 21.905 [1] and the following apply. An abbreviation defined in the present document takes precedence over the definition of the same abbreviation, if any, in TR 21.905 [1].

BM-SC	Broadcast-Multicast Service Centre
EPC	Evolved Packet Core
MCE	Multi-cell/multicast Coordination Entity
MME	Mobility Management Entity
RNL	Radio Network Layer
TNL	Transport Network Layer

4 General Architecture for E-UTRAN MBMS

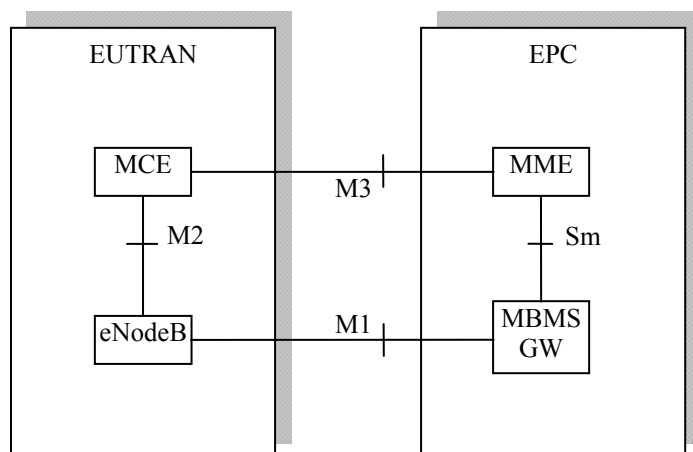

Figure 4-1 General Architecture for E-UTRAN MBMS

Figure 4-1 shows a simplified architecture for MBMS in LTE/SAE. It consists of EPC functional entities and E-UTRAN nodes. Functions of MBMS EPC entities are defined in TS 23.246 [8]. Functions of MBMS E-UTRAN nodes are defined in TS 36.300 [9]. It should be noted that TS 36.300 [9] also allows MCE be deployed inside eNodeB.

Interfaces related to E-UTRAN (i.e. M1, M2 and M3) are introduced in this document. For MBMS, control signaling and user plane data packet are distributed from the EPC to E-UTRAN through different interfaces.

- **Control plane interfaces**

M3, M2 interface are pure control plane interfaces.

M3 between MME and MCE mainly carries MBMS session management signaling.

A MCE is connected to one or more than one eNBs within the same MBSFN through M2 interface mainly for MBMS session management signaling and radio configuration signaling.

- **User plane interface**

M1 interface is a pure user plane interface.

A MBMS GW is connected to multiple eNBs through M1 interface for data distribution.

Reference points within EPC are not in the scope of this document. Please refer to TS 23.246 [8] for details.

5 Functions of M1 interface for MBMS

5.1 General

“M1” Interface: MBMS GW – eNB

The M1 interface is the user plane interface of MBMS between MBMS GW and eNB. IP multicast is used to deliver the downlink packets over the M1 interface and there is no uplink data over M1 radio network layer. SYNC protocol (TS 25.446 [7]) is used over the M1 interface to keep the content synchronization for MBMS service data transmission.

5.2 Multicast group management function

IP multicast is used to deliver the packets over the M1 interface. The M1 interface has the function to manage the IP multicast groups. The MBMS GW maintains the IP multicast groups. The MBMS GW allocates the IP multicast group address when the session arrives, and may release it at session stop. At the eNB side, the eNB joins the IP multicast group to receive the MBMS User Plane data at session start, leaves the IP multicast group when the session stops, may leave the IP multicast group when the session suspends and may rejoin the IP multicast group when the session resumes.

5.3 Content synchronization function

The packets delivered over M1 interface will be synchronously transmitted by eNBs. To support the inter-eNB content synchronization, SYNC protocol layer is defined between BM-SC to eNB, which is used to carry additional information that enable eNBs to identify the timing for radio frame transmission and detect packet loss. Every packet in M1 contains the SYNC protocol information which is encapsulated at BM-SC.

6 Functions of M2 interface for MBMS

6.1 General

“M2” Interface: MCE – eNB

An Application Part (M2AP) is defined in TS 36.443 [4] for this interface, which conveys at least radio configuration data for the multi-cell transmission mode eNBs and Session Control Signaling. SCTP (IETF RFC 4960 [10]) is used as signaling transport i.e. Point-to-Point signaling is applied.

6.2 M2 interface setup and configuration update functions

The M2 Setup (respectively the eNB and MCE configuration update) function allows to exchange (respectively update) application level data needed for the eNB and MCE to interoperate correctly on the M2 interface after the TNL association has become operational.

6.3 MBMS Session management function

6.3.1 M2 service context management function

The M2 service context management function supports the establishment of the necessary overall initial service context including MBMS E-RAB context, M2 signalling connection ID(s), etc.

The establishment of the overall initial M2 service context is initiated by the MCE.

The M2 service context management function also supports the release of the context previously established in the eNB due to service termination. The release of the context is triggered by the MCE.

6.3.2 MBMS E-RAB management functions

The MBMS E-RAB service management function is responsible for establishing and releasing E-UTRAN resources for service data transport. The establishment of E-UTRAN resources is triggered by the MCE. The release of E-UTRAN resources is triggered by the MCE.

6.3.3 M2 link management function

The M2 signalling link management function provides a reliable transfer of the radio network signalling between eNBs and MCE. The SCTP is used to support the exchange of M2 Application Protocol (M2AP) signalling messages between eNBs and MCE.

6.3.4 MBMS Service Suspension and Resumption function

The MBMS Service Suspension function allows the MCE to request the eNB to stop the MBSFN transmission of an ongoing service and release associated RAN resources while keeping the MBMS context in the eNB.

The MBMS Service Resumption function allows to resume a previously suspended MBMS Session.

6.4 MBMS Scheduling Information transfer function

This function provides multiplexing information if more than one MBMS service is active. The MCE allocates the amount of resources to multiplexed services, using service related information. The eNBs accept the MBMS Scheduling information to synchronize the MCCH transmission in the MBSFN area.

6.5 MBMS signalling synchronization over M2

The M2 interface shall support timing and synchronization management functions. MCE transmits the control information to eNBs through M2 interface. Synchronization function guarantees the corresponding MCCH to be transmitted at all eNBs simultaneously.

6.6 M2 interface reset and error processing function

These functions allow for managing of signalling associations between eNB-MCE, surveying M2 interface and recovering from errors.

6.6.1 Error indication

This function allows the reporting of general error situations on signalling exchange.

6.6.2 Reset

The reset function is used to initialize the peer entity after node setup or after a failure event occurred. The reset function may also be used to initialize part of the peer entity. This procedure can be used by both the eNB and MCE.

6.7 MBMS Counting Function

The MBMS Counting function allows the MCE to request the eNB(s) to count and report per MBSFN area for one or more MBMS services the number of connected UEs receiving the MBMS Service or interested in receiving it.

7 Functions of M3 interface for MBMS

7.1 General

“M3” Interface: MME – MCE

M3 provides the signalling service between MCE and MME that is required to fulfil the M3AP functions listed in TS 36.444 [5]. SCTP (IETF RFC 4960 [10]) is used as signaling transport i.e. Point-to-Point signaling is applied.

7.2 MBMS Session management function

MBMS session management function is responsible for starting and stopping MBMS sessions.

7.2.1 M3 service context management function

The M3 service context management function supports the establishment of the necessary E-MBMS service context including E-MBMS E-RAB context, M3 signalling connection ID(s), etc.

The establishment of the M3 service context is initiated by the MME. The M3 service context management function also supports the release of the context previously established in the MCE due to service termination. The release of the M3 context is triggered by the MME.

7.2.2 MBMS E-RAB management functions

The E-MBMS E-RAB service management function is responsible for establishing and releasing E-UTRAN resources for E-MBMS services. The establishment of E-UTRAN resources is triggered by the MME and requires respective QoS information to be provided to the MCE. The release of E-UTRAN resources is triggered by the MME.

7.3 M3 interface reset and error processing function

These functions allow for managing of signalling associations between MME-MCE, surveying M3 interface and recovering from errors.

7.3.1 Error indication

The error indication function is used by the MCE (respectively the MME) to indicate to the MME (respectively the MCE) that a logical error has occurred.

7.3.2 Reset

The reset function is used to initialize the peer entity after node setup or after a failure event occurred. The reset function may also be used to initialize part of the peer entity. This procedure can be used by both the MCE and MME.

8 Protocol structure for MBMS related interface in E-UTRAN

8.1 General

MBMS related E-UTRAN interfaces, M1, M2 and M3, are layered into a Radio Network Layer (RNL) and a Transport Network Layer (TNL).

The radio network signalling over M3 consists of the M3 Application Protocol (M3AP). The M3AP protocol (TS 36.444 [5]) consists of procedures between the EPC and E-UTRAN for MBMS.

The radio network signalling over M2 consists of the M2 Application Protocol (M2AP). The M2AP protocol (TS 36.443 [4]) consists of procedures between the MCE and eNB for MBMS.

8.2 M1

The protocol stack structure for M1 interface is defined in TS 36.445 section 5.1 [6].

MBMS user data is distributed from the MBMS GW to eNBs by using IP multicast through the M1 interface. An eNB joins the IP multicast address allocated by MBMS GW during the MBMS Session Start procedure (TS 23.246 [8]).

8.3 M2

The protocol stack structure for M2 interface is defined in TS 36.442 section 4.1.1 [3].

8.4 M3

The protocol stack structure for M3 interface is defined in TS 36.442 section 5.1.1 [3].

9 Other MBMS E-UTRAN Interface Specifications

9.1 Layer 1 for interfaces supporting MBMS within E-UTRAN (3GPP TS 36.441)

TS 36.441 [2] specifies the physical layer technologies that may be used to support the M1, M2 and M3 interface for MBMS in E-UTRAN.

9.2 Signalling Transport for interfaces supporting MBMS within E-UTRAN (3GPP TS 36.442)

TS 36.442 [3] specifies the signalling bearers for the M2AP for the M2 interface and the M3AP for the M3 interface.

9.3 E-UTRAN M2 Application Protocol (M2AP) (3GPP TS 36.443)

TS 36.443 [4] specifies the M2AP protocol for radio network control plane signalling over the M2 interface.

9.4 E-UTRAN M3 Application Protocol (M3AP) (3GPP TS 36.444)

TS 36.444 [5] specifies the M3AP protocol for radio network control plane signalling over the M3 interface.

9.5 E-UTRAN M1 Data Transport (3GPP TS 36.445)

TS 36.445 [6] specifies the transport bearers for the user plane of the M1 interface.

9.6 E-UTRAN MBMS synchronisation protocol (3GPP TS 25.446)

TS 25.446 [7] specifies the MBMS synchronisation protocol over the M1 interface.

Annex A (informative): Change history

TSG #	TSG Doc.	CR	Rev	Subject/Comment	New
2009-10				Scope, Skeleton	0.0.0
2009-11				Update according to the comments from RAN3#66 meeting	1.0.0
2009-12				Presented for approval at RAN#46	2.0.0
46	RP-091253			Approved at RAN#46	9.0.0
47	RP-100226	0001	2	Incorrect reference for SYNC spec	9.1.0
2010-12				Creation of Rel-10 version based on v. 9.1.0	10.0.0
SP-49	SP-100629			Clarification on the use of References (TS 21.801 CR#0030)	10.0.1
52	RP-110684	0003		Correction of References	10.1.0
52	RP-110686	0004	2	Completion with Release 10 functions	10.1.0
53	RP-111197	0007	1	Removal the QoS information in the M2 interface	10.2.0
56	RP-120744	0008		Correction of Reset	10.3.0